



## AIR CONDITIONING SYSTEMS DUCT TYPE

- **USER'S MANUAL**
- **ΕΓΧΕΙΡΙΔΙΟ ΧΡΗΣΗΣ**
- **MANUAL UTILIZATORULUI**



### **MODELS:**

V4MDI-18/U4MRS-18  
V4MDI-24/U4MRS-24  
V4MDI-36/U4MRS-36  
V4MDI-42/U4MRT-42  
V4MDI-50/U4MRT-50  
V4MDI-60/U4MRT-60



**INDOOR UNIT**

**OUTDOOR UNIT**

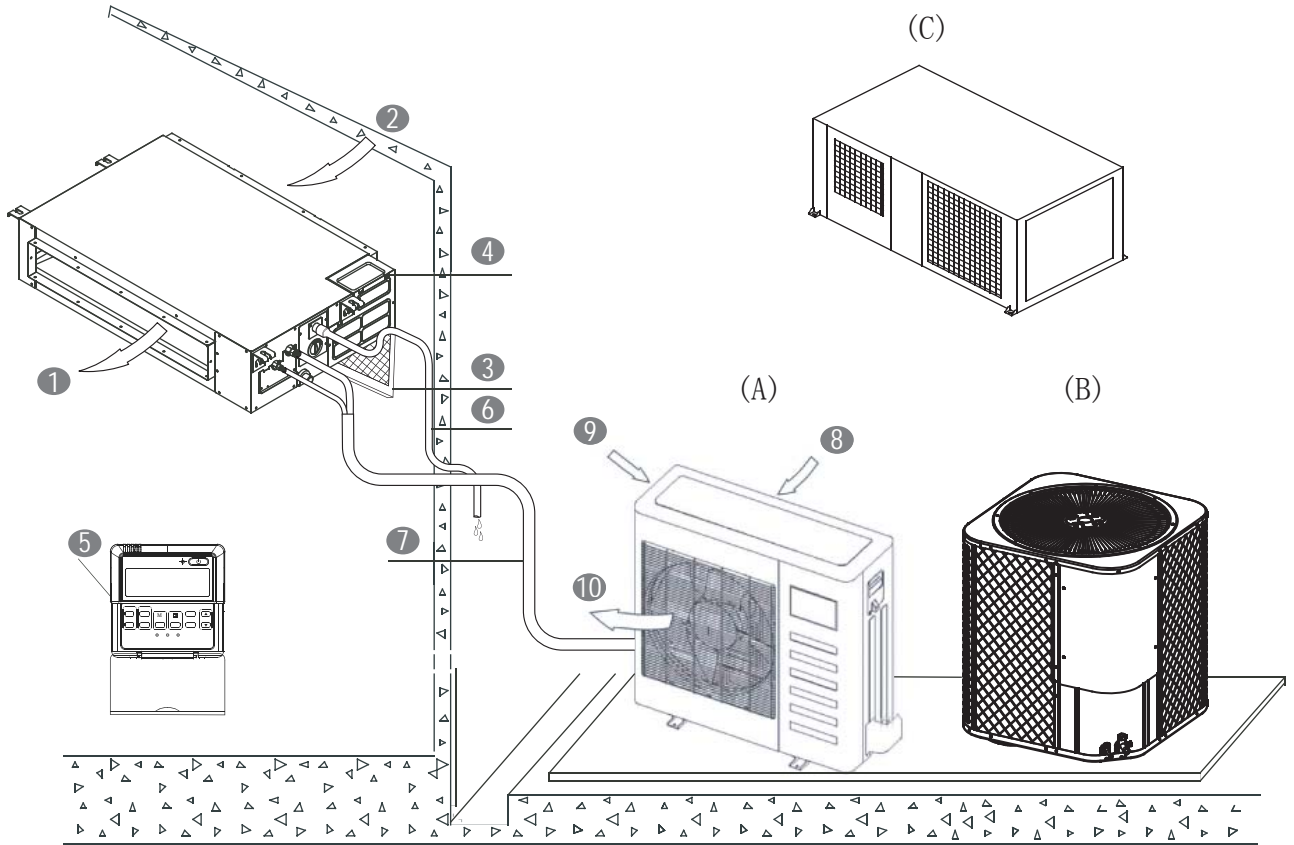

Fig.1

**INDOOR UNIT**

- ① Air outlet
- ② Air inlet
- ③ Air filter(on some models)
- ④ Electric control cabinet
- ⑤ Wire controller(on some models)
- ⑥ Drain pipe

**OUTDOOR UNIT(A,B,C)**

- ⑦ Connecting pipe
- ⑧ Air inlet
- ⑨ Air inlet(side and rear)
- ⑩ Air outlet



**NOTE**

All the pictures in this manual are for explanation purpose only. They may be slightly different from the air conditioner you purchased(depend on model).The actual shape shall prevail.

IMPORTANT SAFETY INFORMATION.....	1
PARTS NAMES.....	2
AIR CONDITIONER OPERATIONS AND PERFORMANCE.....	3
HINTS FOR ECONOMICAL OPERATION.....	3
MAINTENANCE.....	3
FOLLOWING SYMPTOMS ARE NOT AIR CONDITIONER TROUBLES.....	5
TROUBLESHOOTING.....	6

# 1. IMPORTANT SAFETY INFORMATION

To prevent injury to the user or other people and property damage, the following instructions must be followed. Incorrect operation due to ignoring of instructions may cause harm or damage.

The safety precautions listed here are divided into two categories. In either case, important safety information is listed which must be read carefully.



## WARNING

The appliance shall be installed in accordance with national wiring regulations. Failure to observe a warning may result in death.



## CAUTION

Failure to observe a caution may result in injury or damage to the equipment.



## WARNING

**Ask your dealer for installation of the air conditioner.**  
Incomplete installation performed by yourself may result in a water leakage, electric shock, and fire.

**Ask your dealer for improvement, repair, and maintenance.**  
Incomplete improvement, repair, and maintenance may result in a water leakage, electric shock, and fire.

**In order to avoid electric shock, fire or injury, or if you detect any abnormality such as smell of fire, turn off the power supply and call your dealer for instructions.**

**Never let the indoor unit or the remote controller get wet.**  
It may cause an electric shock or a fire.

**Never press the button of the remote controller with a hard, pointed object.**  
The remote controller may be damaged.

**Never replace a fuse with that of wrong rated current or other wires when a fuse blows out.**  
Use of wire or copper wire may cause the unit to break down or cause a fire.

**It is not good for your health to expose your body to the air flow for a long time.**

**Do not insert fingers, rods or other objects into the air inlet or outlet.**  
When the fan is rotating at high speed, it will cause injury.

**Never use a flammable spray such as hair spray, lacquer or paint near the unit.**  
It may cause a fire.

**Never touch the air outlet or the horizontal blades while the swing flap is in operation.**  
Fingers may become caught or the unit may break down.

**Never put any objects into the air inlet or outlet.**  
Objects touching the fan at high speed can be dangerous.

**Never inspect or service the unit by yourself.**  
Ask a qualified service person to perform this work.

**Do not dispose this product as unsorted municipal waste. Collection of such waste separately for special treatment is necessary.**

Do not dispose of electrical appliances as unsorted municipal waste, use separate collection facilities.  
Contact you local government for information regarding the connection systems available.

**If electrical appliances are disposed of in landfills or dumps, hazardous substances can leak into the groundwater and get into the food chain, damaging your health and well-being**

**To prevent refrigerant leak, contact your dealer.**  
When the system is installed and runs in a small room, it is required to keep the concentration of the refrigerant, if by any chance coming out, below the limit. Otherwise, oxygen in the room may be affected, resulting in a serious accident.

**The refrigerant in the air conditioner is safe and normally does not leak.**  
If the refrigerant leaks in the room, contact with a fire of a burner, a heater or a cooker may result in a harmful gas.

**Turn off any combustible heating devices, ventilate the room, and contact the dealer where you purchased the unit.**  
Do not use the air conditioner until a service person confirms that the portion where the refrigerant leaks is repaired.



## CAUTION

**Do not use the air conditioner for other purposes.**  
In order to avoid any quality deterioration, do not use the unit for cooling precision instruments, food, plants, animals or works of art.

**Before cleaning, be sure to stop the operation, turn the breaker off or pull out the supply cord.**  
Otherwise, an electric shock and injury may result.

**In order to avoid electric shock or fire, make sure that an earth leak detector is installed.**

**Be sure the air conditioner is grounded.**  
In order to avoid electric shock, make sure that the unit is grounded and that the earth wire is not connected to gas or water pipe, lightning conductor or telephone earth wire.

**In order to avoid injury, do not remove the fan guard of the outdoor unit.**

**Do not operate the air conditioner with a wet hand.**  
An electric shock may happen.

**Do not touch the heat exchanger fins.**  
These fins are sharp and could result in cutting injuries.

**Do not place items which might be damaged by moisture under the indoor unit.**  
Condensation may form if the humidity is above 80%, the drain outlet is blocked or the filter is polluted.

**After a long use, check the unit stand and fitting for damage.**  
If damaged, the unit may fall and result in injury.

**To avoid oxygen deficiency, ventilate the room sufficiently if equipment with burner is used together with the air conditioner.**

**Arrange the drain hose to ensure smooth drainage.**  
Incomplete drainage may cause wetting of the building, furniture etc.

**Never touch the internal parts of the controller.**  
Do not remove the front panel. Some parts inside are dangerous to touch, and a machine trouble may happen.

**Never expose little children, plants or animals directly to the air flow.**  
Adverse influence to little children, animals and plants may result.

**Do not allow a child to mount on the outdoor unit or avoid placing any object on it.**  
Falling or tumbling may result in injury.

**Do not operate the air conditioner when using a room fumigation - type insecticide.**  
Failure to observe could cause the chemicals to become deposited in the unit, which could endanger the health of those who are hypersensitive to chemicals.

**Do not place appliances which produce open fire in places exposed to the air flow from the unit or under the indoor unit.**  
It may cause incomplete combustion or deformation of the unit due to the heat.

**Do not install the air conditioner at any place where flammable gas may leak out.**  
If the gas leaks out and stays around the air conditioner, a fire may break out.

**The appliance is not intended for use by young children or infirm persons without supervision.**

**Do not operate your air conditioner in a wet room such as a bathroom or laundry room.**

**This appliance can be used by children aged from 8 years and above and persons with reduced physical, sensory or mental capabilities or lack of experience and knowledge if they have been given supervision or instruction concerning use of the appliance in a safe way and understand the hazards involved. Children shall not play with the appliance. Cleaning and user maintenance shall not be made by children without supervision.**

This appliance is not intended for use by persons (including children) with reduced physical, sensory or mental capabilities, or lack of experience and knowledge, unless they have been given supervision or instruction concerning use of the appliance by a person responsible for their safety.

Children should be supervised to ensure that they do not play with the appliance.

If the supply cord is damaged, it must be replaced by the manufacturer, its service agent or similarly qualified persons in order to avoid a hazard.

## 2. PARTS NAMES

**The air conditioner consists of the indoor unit, the outdoor unit, the connecting pipe and the remote controller.**  
(Refer to Fig.2-1)

### Function indicators on indoor unit display panel

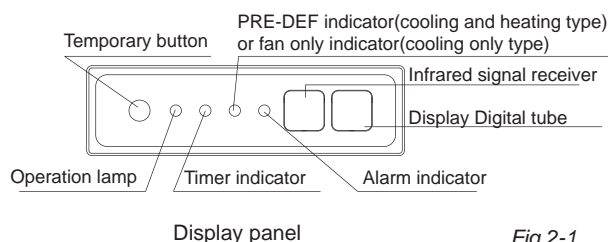

Fig.2-1

For inverter type, this switch is used for after-sales service purpose only, the user should not push it.

For fixed-frequency type, this function is used to operate the unit temporarily in case you misplace the remote controller or its batteries are exhausted. Two modes including FORCED AUTO and FORCED COOL can be selected through the TEMPORARY BUTTON on the air-in grill control box of the indoor unit. Once you push this button, the air conditioner will run in such order: FORCED AUTO, FORCED COOL, OFF, and back to FORCED AUTO.

- 1 FORCED AUTO**  
The OPERATION lamp is lit, and the air conditioner will run under FORCED AUTO mode. The remote controller operation is enabled to operate according to the received signal.
- 2 FORCED COOL**  
The OPERATION lamp flashes, the air conditioner will turn to FORCED AUTO after it is enforced to cool with a wind speed of HIGH for 30 minutes. The remote controller operation is disabled.
- 3 OFF**  
The OPERATION lamp goes off. The air conditioner is OFF while the remote controller operation is enabled.



### NOTE

This manual does not include Remote Controller Operations, see the <<Remote Controller Owner's manual>> packed with the unit for details.

### 3. AIR CONDITIONER OPERATIONS AND PERFORMANCE

Use the system in the following temperature for safe and effective operation. The Max operation temperature for the air conditioner. (Cooling/Heating)

Table 2-1

Mode \ Temperature	Outdoor temperature	Room temperature
Cooling operation	18°C ~ 43°C / 64 °F~109°F	17°C ~ 32°C (62 °F ~ 90°F)
	-7°C ~ 43°C / 20 °F~109°F (for the models with low temperature cooling system)	
	18°C ~ 52°C / 64 °F~126°F (for special tropical models)	
Heating operation (cooling only type without)	-7°C ~ 24°C / 20 °F ~ 76°F	0°C ~ 30°C / 32 °F~86°F
Dry operation	18°C ~ 43°C / 64 °F~109°F	17°C ~ 32°C (62 °F ~ 90°F)
	18°C ~ 52°C / 64 °F~126°F (for special tropical models)	

Table 2-2(for inverter type air conditioner)

Mode \ Temperature	Outdoor temperature	Room temperature
Cooling operation	0°C ~ 50°C / 32 °F~122°F	17°C ~ 32°C (62°F ~ 90°F)
	-15°C ~ 50°C / 5 °F~122°F (for the models with low temperature cooling system)	
Heating operation (cooling only type without)	-15°C ~ 24°C / 5 °F~76°F	0°C ~ 30°C (32°F ~ 86°F)
Dry operation	0°C ~ 50°C / 32 °F~122°F	17°C ~ 32°C (62°F ~ 90°F)



#### NOTE

- 1 If air conditioner is used outside the above conditions, it may cause the unit to function abnormally.
- 2 The phenomenon is normal that the surface of air conditioning may condense water when the relative larger humidity in room, please close the door and window.
- 3 Optimum performance will be achieved within these operating temperature range.

#### Three-minute protection feature

A protection feature prevents the air conditioner from being activated for approximately 3 minutes when it restarts immediately after operation.

#### Power failure

Power failure during operation will stop the unit completely.

- The OPERATION lamp on the indoor unit will start flashing when power is restored.
- To restart operation, push the ON/OFF button on the remote controller.
- Lightning or a car wireless telephone operating nearby may cause the unit to malfunction.

### 4. HINTS FOR ECONOMICAL OPERATION

The following should be noticed to ensure an economical operation. (Refer to corresponding chapter for details)

- Adjust the air flow direction properly to avoid winding toward your body.
- Adjust the room temperature properly to get a comfortable situation and to avoid supercooling and superheat.
- In cooling, close the curtains to avoid direct sunlight.
- To keep cool or warm air in the room, never open doors or windows more often than necessary.
- Set the timer for the desired operating time.
- Never put obstructions near the air outlet or the air inlet. Or it will cause lower efficiency, even a sudden stop.
- Adjust the air flow direction properly to avoid winding toward your body.
- Adjust the room temperature properly to get a comfortable situation and to avoid supercooling and superheat.
- In cooling, close the curtains to avoid direct sunlight.
- To keep cool or warm air in the room, never open doors or windows more often than necessary.
- If you don't plan to use the unit for a long time, please disconnect power and remove the batteries from the remote controller. When the power switch is connected, some energy will be consumed, even if the air conditioner isn't in operation. So please disconnect the power to save energy. And please switch the power on 12 hours before you restart the unit to ensure a smooth operation.
- A clogged air filter will reduce cooling or heating efficiency, please clean it once two weeks.

### 5. MAINTENANCE



#### CAUTION

**Before you clean the air conditioner, be sure the power supply is off.**

**Check if the wiring is not broken off or disconnected.**

**Use a dry cloth to wipe the indoor unit and remote controller.**

**A wet cloth may be used to clean the indoor unit if it is very dirty.**

**Never use a damp cloth on the remote controller.**

Do not use a chemically-treated duster for wiping or leave such material on the unit for long. it may damage or fade the surface of the unit.

Do not use benzene, thinner, polishing powder, or similar solvents for cleaning. These may cause the plastic surface to crack or deform.

■ **Maintenance after a long stop period**

(eg. at the beginning of the season)

Check and remove everything that might be blocking inlet and outlet vents of indoor units and outdoor units.

Clean air filters and casings of indoor units. Refer to "Cleaning the air filter" for details on how to proceed and make sure to install cleaned air filters back in the same position.

Check and remove everything that might be blocking inlet and outlet vents of indoor units and outdoor units.

Clean air filters and casings of indoor units. Refer to "Cleaning the air filter" for details on how to proceed and make sure to install cleaned air filters back in the same position.

Turn on the power at least 12 hours before operating the unit in order to ensure smoother operation. As soon as the power is turned on, the remote controller displays appear.

■ **Maintenance before a long stop period**

(eg. at the end of the season)

Let the indoor units run in fan only operation for about half a day in order to dry the interior of the units.

Clean air filters and casings of indoor units. Refer to "Cleaning the air filter" for details on how to proceed and make sure to install cleaned air filters back in the same position.

■ **Cleaning the air filter(on some models)**

The air filter can prevent the dust or other particulate from going inside. In case of blockage of the filter, the working efficiency of the air conditioner may greatly decrease. Therefore, the filter must be cleaned once two weeks during long time usage.

If the air conditioner is installed in a dust place, clean the the air filter frequent.

If the accumulated dust is too heavy to be cleaned, please replace the filter with a new one(replaceable air filter is an optional fitting).

The filter cleaning should be performed by a suitable service provider.

- For your purchasing unit is a rear ventilated one, please remove the filter fixed screws (2 screws) and take down the filter away from the unit.

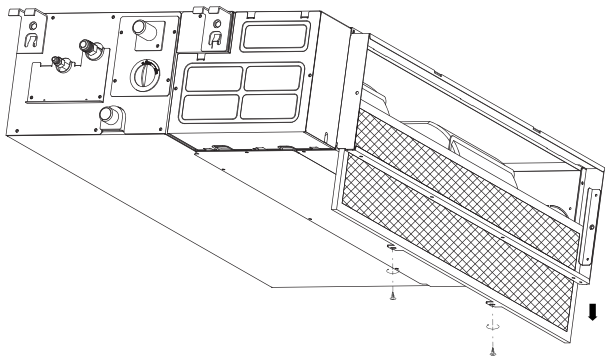

Fig.5-1

- For your purchasing unit is a descensional ventilated one, please push the filter up slightly to let the position retainer escape away from the flange fixed holes, and take off the filter according to the arrow direction shows in the following fig.

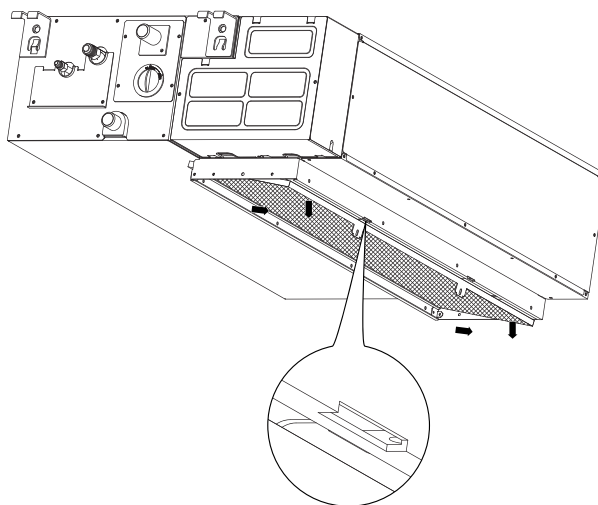

Fig.5-2

- Clean the air filter (Vacuum cleaner or pure water may be used to clean the air filter. If the dust accumulation is too heavy, please use soft brush and mild detergent to clean it and dry out in cool place).

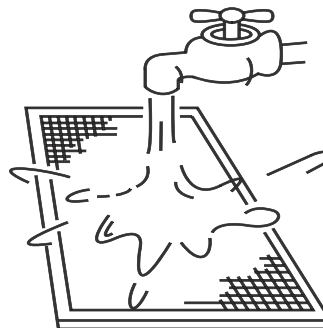

Fig.5-3

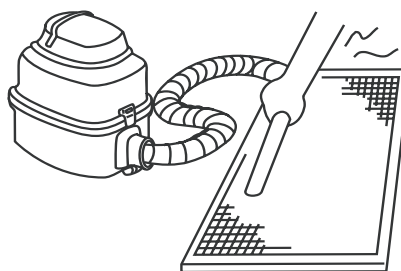

Fig.5-4

The air-in side should face up when using vacuum cleaner.

(Refer to Fig.5-4)

The air-in side should face down when using water. (Refer to Fig.5-3)



## CAUTION

Do not dry out the air filter under direct sunshine or with fire.

5. Re-install the air filter

6. Install and close the air-in grill in the reverse order of step 1 and 2 and connect the control box cables to the corresponding terminators of the main body .

## 6. FOLLOWING SYMPTOMS ARE NOT AIR CONDITIONER TROUBLES

### Symptom 1: The system does not operate

- The air conditioner does not start immediately after the ON/OFF button on the remote controller is pressed.  
If the operation lamp lights, the system is in normal condition. To prevent overloading of the compressor motor, the air conditioner starts 3 minutes after it is turned ON.
- If the operation lamp and the "PRE-DEF indicator(cooling and heating type) or fan only indicator(cooling only type)" light, it means you choose the heating model, When just starting, if the compressor has not started, the indoor unit appears "anti cold wind" protection because of its overflow outlet temperature.

### Symptom 2: Change into the fan mode during cooling mode

- In order to prevent the indoor evaporator frosting, the system will change into fan mode automatically, restore to the cooling mode after soon.
- When the room temperature drops to the set temperature, the compressor goes off and the indoor unit changes to fan mode; when the temperature rises up, the compressor starts again. It is same in the heating mode.

### Symptom 3: White mist comes out of a unit

#### Symptom 3.1: Indoor unit

- When humidity is high during cooling operation If the interior of an indoor unit is extremely contaminated, the temperature distribution inside a room becomes uneven. It is necessary to clean the interior of the indoor unit. Ask your dealer for details on cleaning the unit. This operation requires a qualified service person

### Symptom 3.2: Indoor unit, outdoor unit

- When the system is changed over to heating operation after defrost operation Moisture generated by defrost becomes steam and is exhausted.

## Sptom 4: Noise of air conditionerscooling

### Symptom 4.1: Indoor unit

- A continuous low "shah" sound is heard when the system is in cooling operation or at a stop.  
When the drain pump (optional accessories) is in operation, this noise is heard.
- A "pishi-pishi" squeaking sound is heard when the system stops after heating operation.  
Expansion and contraction of plastic parts caused by temperature change make this noise.

### Symptom 4.2: Indoor unit, outdoor unit

- A continuous low hissing sound is heard when the system is in operation.  
This is the sound of refrigerant gas flowing through both indoor and outdoor units.
- A hissing sound which is heard at the start or immediately after stopping operation or defrost operation.  
This is the noise of refrigerant caused by flow stop or flow change.

### Symptom 4.3: Outdoor unit

- When the tone of operating noise changes.  
This noise is caused by the change of frequency.

## Symptom 5: Dust comes out of the unit

- When the unit is used for the first time in a long time.  
This is because dust has gotten into the unit.

## Symptom 6: The units can give off odours

- The unit can absorb the smell of rooms, furniture, cigarettes, etc., and then emit it again.

## Symptom 7: The outdoor unit fan does not spin.

- During operation. The speed of the fan is controlled in order to optimize product operation.

## 7. TROUBLESHOOTING

### 7.1. Troubles and causes of air conditioner

If one of the following malfunctions occur, stop operation, shut off the power, and contact with your dealer.

- The operation lamp is flashing rapidly (5Hz). This lamp is still flashing rapidly after turn off the power and turn on again. (Refer to Table 7-1a, Table 7-1b and Table 7-2)
- Remote controller receives malfunction or the button does not work well.
- A safety device such as a fuse, a breaker frequently actuates.
- Obstacles and water enter the unit.
- Water leaks from indoor unit.
- Other malfunctions.

If the system does not properly operate except the above mentioned cases or the above mentioned malfunctions is evident, investigate the system according to the following procedures. (Refer to Table 7-3)



#### CAUTION

















---

Please cut off the power supply when appearing the above malfunction, check if the voltage provided is out of range, check if the installation of air-conditioner is correct, then electrify again after 3 minutes power off. If the problem is still existent, please contact the local service station or the equipment provider.

---





Table 7-1a

NO.	MALFUNCTION & PROTECTION DEFINE	LED1 OPERATION	LED2 TIMER	LED3 DEF.FAN	LED4 ALARM	DISPLAY DIGITAL TUBE
1	Indoor fan motor speed out of control					E8
2	In-Outdoor unit COMM. Checking channel is abnormal					E1
3	Room TEMP. sensor checking channel is abnormal					E2
4	Pipe TEMP. Sensor checking channel is abnormal(T2)					E3
5	Pipe TEMP. Sensor checking channel is abnormal(T2B)					E4
6	EPPROM malfunction					E7
7	Water-level alarm malfunction					EE
8	Outdoor malfunction					Ed
9	Indoor twins communication malfunction					F3
10	Other malfunction of twins					F4
		 Light	 Flashing at 2.5HZ	 Flashing at 0.5HZ		

**Applicable to inverter air conditioner only**

Table 7-1b

• • •	MALFUNCTION & PROTECTION DEFINE	LED1 OPERATION	LED2 TIMER	LED3 DEF.FAN	LED4 ALARM	DISPLAY DIGITAL TUBE
•	Room temperature sensor checking channel is abnormal		○			E2
•	Pipe temperature sensor checking channel is abnormal	○				E3
•	Outdoor TEMP. sensor checking channel is abnormal			○		E4
•	Outdoor unit malfunction	○	○	○	○	E6
•	Pump temperature sensor malfunction				○	E5
•	EEPROM malfunction	○	○			E7
•	Water-level alarm malfunction				○	E8
•	DC motor speed out of control		○		○	Eb
•	Outdoor unit low pressure malfunction	○	○	○		Ed
 Light  Flashing at 5HZ  Flashing at 1HZ						

**Applicable to fixed-frequency air conditioner only**

Table 7-2

Symptoms	Causes	Solution
<b>Unit does not start</b>	<ul style="list-style-type: none"> <li>Power failure.</li> <li>Power switch is off.</li> <li>Fuse of power switch may have burned.</li> <li>Batteries of remote controller exhausted or other problem of controller.</li> </ul>	<ul style="list-style-type: none"> <li>Wait for the comeback of power.</li> <li>Switch on the power.</li> <li>Replace.</li> <li>Replace the batteries or check the controller.</li> </ul>
<b>Air flowing normally but completely can't cooling</b>	<ul style="list-style-type: none"> <li>Temperature is not set correctly.</li> <li>Be in 3 minutes protection of compressor.</li> </ul>	<ul style="list-style-type: none"> <li>Set the temperature properly.</li> <li>Wait.</li> </ul>
<b>Units start or stop frequently</b>	<ul style="list-style-type: none"> <li>Refrigerant is too little or too much.</li> <li>Air or no concretingc gas in the refrigerating circuit.</li> <li>Compressor is malfunction.</li> <li>Voltage is too high or too low.</li> <li>System circuit is blocked.</li> </ul>	<ul style="list-style-type: none"> <li>Check leakage, and rightly recharge refrigerant.</li> <li>Vacuum and recharge refrigerant.</li> <li>Maintenance or change compressor.</li> <li>Install manostat.</li> <li>Find reasons and solution.</li> </ul>
<b>Low cooling effect</b>	<ul style="list-style-type: none"> <li>Outdoor unit and indoor unit heat exchanger is dirty.</li> <li>The air filter is dirty.</li> <li>Inlet/outlet of indoor/outdoor units is blocked.</li> <li>Doors and windows are open</li> <li>Sunlight directly shine.</li> <li>Too much heat resource.</li> <li>Outdoor temp. is too high.</li> <li>Leakage of refrigerant or lack of refrigerant.</li> </ul>	<ul style="list-style-type: none"> <li>Clean the heat exchanger.</li> <li>Clean the air filter.</li> <li>Eliminate all dirties and make air smooth.</li> <li>Close doors and windows.</li> <li>Make curtains in order to shelter from sunshine.</li> <li>Reduce heat source.</li> <li>AC cooling capacity reduces (normal).</li> <li>Check leakage and rightly recharge refrigerant.</li> </ul>
<b>Low heating effect</b>	<ul style="list-style-type: none"> <li>Outdoor temperature is lower than 7°C</li> <li>Doors and windows not completely closed.</li> <li>Leakage of refrigerant or lack of refrigerant.</li> </ul>	<ul style="list-style-type: none"> <li>Use heating device.</li> <li>Close doors and windows.</li> <li>Check leakage and rightly recharge refrigerant.</li> </ul>

## 7.2. Troubles and causes of wire controller

Before asking for serving or repairing , check the following points. (Refer to Table 7-3)

Table 7-3

Symptoms	Solution	Causes
The fan speed can not be changed.	<ul style="list-style-type: none"> <li>Check whether the MODE indicated on the display is "AUTO"</li> </ul>	When the automatic mode is selected, the air conditioner will automatically change the fan speed.
	<ul style="list-style-type: none"> <li>Check whether the MODE indicated on the display is "DRY"</li> </ul>	When dry operation is selected, the air conditioner automatically change the fan speed. The fan speed can be selected during "COOL" , "FAN ONLY" , and "HEAT"
The wire controller signal is not transmitted even when the ON/OFF button is pushed.	<ul style="list-style-type: none"> <li>Check whether the signal transmitter of the wire controller is properly directed to the infrared signal receiver of the indoor unit.</li> </ul>	The power supply is off.
The TEMP. indicator does not come on.	<ul style="list-style-type: none"> <li>Check whether the MODE indicated on the display is FAN ONLY</li> </ul>	The temperature cannot be set during FAN mode.
The indication on the display disappears after a lapse of time.	<ul style="list-style-type: none"> <li>Check whether the timer operation has come to an end when the TIMER OFF is indicated on the display.</li> </ul>	The air conditioner operation will stop up to the set time
The TIMER ON indicator goes off after a lapse of certain time.	<ul style="list-style-type: none"> <li>Check whether the timer operation is started when the TIMER ON is indicated on the display.</li> </ul>	Up to the set time, the air conditioner will automatically start and the appropriate indicator will go off.
No receiving tone sounds from the indoor unit even when the ON/OFF button is pressed.	<ul style="list-style-type: none"> <li>Check whether the signal transmitter of the wire controller is properly directed to the infrared signal receiver of the indoor unit when the ON/OFF button is pressed.</li> </ul>	Directly transmit the signal transmitter of the wire controller to the infrared signal receiver of the indoor unit, and then repeatedly push the ON/OFF button twice.

# Activate your warranty.....

in

# 5

simple  
**steps!**



Scan here for the  
warranty form

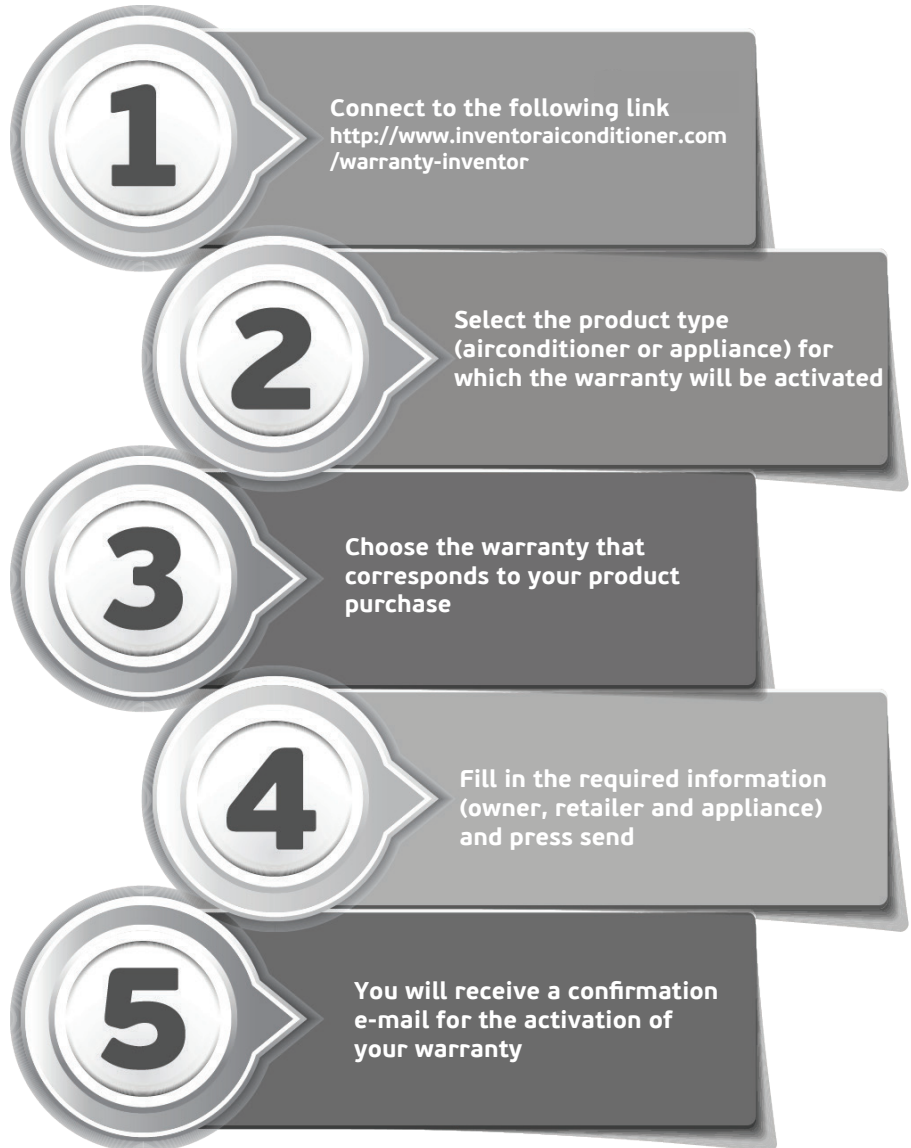

For the electronic  
warranty submission  
please use the following link

**<http://www.inventorairconditioner.com/warranty-inventor>**

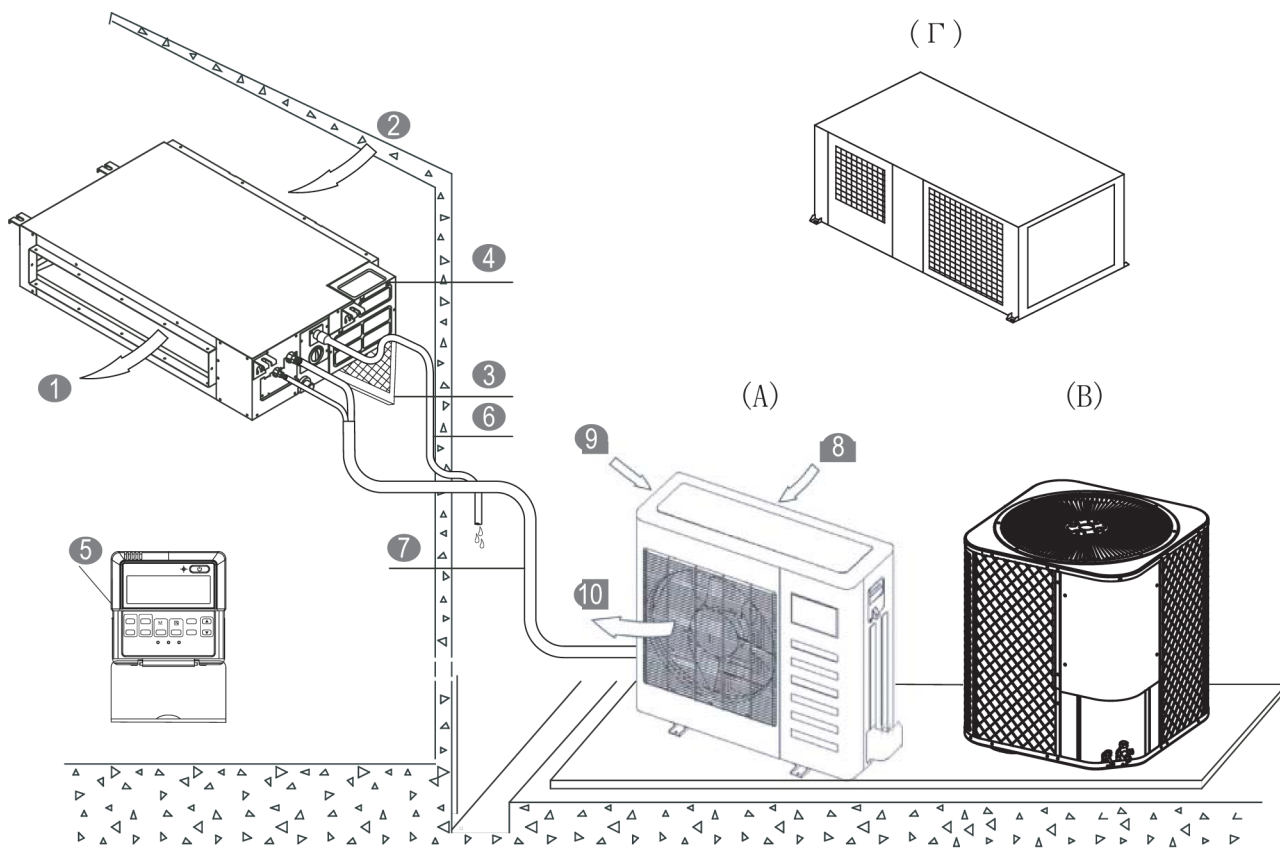
**ΕΣΩΤΕΡΙΚΗ ΜΟΝΑΔΑ****ΕΞΩΤΕΡΙΚΗ ΜΟΝΑΔΑ****Εικ. 1****ΕΣΩΤΕΡΙΚΗ ΜΟΝΑΔΑ**

- ① Έξοδος Αέρα
- ② Είσοδος Αέρα
- ③ Φίλτρο Αέρα (σε ορισμένα μοντέλα)
- ④ Ηλεκτρικό κουτί σύνδεσης
- ⑤ Ενσύρματο Χειριστήριο (σε ορισμένα μοντέλα)
- ⑥ Αγωγός Αποστράγγισης

**ΕΞΩΤΕΡΙΚΗ ΜΟΝΑΔΑ (Α,Β,Γ)**

- ⑦ Σωλήνας Σύνδεσης
- ⑧ Είσοδος Αέρα
- ⑨ Είσοδος Αέρα (πλάι και πίσω)
- ⑩ Έξοδος Αέρα

**ΣΗΜΕΙΩΣΗ**

Όλες οι εικόνες σε αυτό το εγχειρίδιο είναι αναφορικές. Μπορεί να υπάρχει διαφορά σε σχέση με την μονάδα που αγοράσατε (εξαρτάται από το μοντέλο). Αυτό που ισχύει είναι οι πραγματικές διαστάσεις και σχήμα.

ΣΗΜΑΝΤΙΚΕΣ ΠΛΗΡΟΦΟΡΙΕΣ ΑΣΦΑΛΕΙΑΣ.....	1
ΟΝΟΜΑΤΟΛΟΓΙΑ.....	2
ΛΕΙΤΟΥΡΓΙΕΣ ΤΗΣ ΚΛΙΜΑΤΙΣΤΙΚΗΣ ΜΟΝΑΔΑΣ.....	3
ΣΥΜΒΟΥΛΕΣ ΓΙΑ ΟΙΚΟΝΟΜΙΚΗ ΛΕΙΤΟΥΡΓΙΑ.....	3
ΣΥΝΤΗΡΗΣΗ.....	5
ΣΥΜΠΤΩΜΑΤΑ ΠΟΥ ΔΕΝ ΑΠΟΤΕΛΟΥΝ ΒΛΑΒΗ ΤΗΣ ΚΛΙΜΑΤΙΣΤΙΚΗΣ ΜΟΝΑΔΑΣ.....	5
ΑΝΤΙΜΕΤΩΠΙΣΗ ΠΡΟΒΛΗΜΑΤΩΝ.....	6

## 1. ΣΗΜΑΝΤΙΚΕΣ ΠΛΗΡΟΦΟΡΙΕΣ ΑΣΦΑΛΕΙΑΣ

Για την αποφυγή τραυματισμού του χρήστη ή οποιουδήποτε άλλου και καταστροφή περιουσίας, πρέπει να ακολουθηθούν οι παρακάτω οδηγίες ασφαλείας. Εσφαλμένη λειτουργία εξαιτίας αγνόησης των οδηγιών μπορεί να προκαλέσει τραυματισμό.

Οι οδηγίες ασφαλείας που περιγράφονται εδώ είναι χωρισμένες σε 2 κατηγορίες. Σε οποιαδήποτε περίπτωση πρέπει τις οδηγίες ασφαλείας που περιγράφονται να τις διαβάσετε προσεκτικά.



### ΠΡΟΕΙΔΟΠΟΙΗΣΗ

Η μονάδα πρέπει να εγκατασταθεί σύμφωνα με τους εθνικούς κανονισμούς συνδεσμολογίας. Η αγνόηση οποιασδήποτε προειδοποίησης μπορεί να οδηγήσει σε θάνατο.



### ΠΡΟΣΟΧΗ

Η αγνόηση αυτού του συμβόλου μπορεί να προκαλέσει τραυματισμό ή βλάβη στη μονάδα.



### ΠΡΟΕΙΔΟΠΟΙΗΣΗ

**Συμβουλευτείτε τον προμηθευτή σας για την εγκατάσταση της μονάδας.**

Ελλιπής εγκατάσταση από εσάς μπορεί να προκαλέσει διαρροή νερού, ηλεκτροπληξία ή και πυρκαγιά.

**Συμβουλευτείτε τον προμηθευτή σας για οποιαδήποτε βελτίωση, επισκευή και συντήρηση της μονάδας.** Ελλιπής ενέργεια βελτίωσης, επισκευής, συντήρησης από εσάς μπορεί να προκαλέσει διαρροή νερού, ηλεκτροπληξία ή και πυρκαγιά.

Για την αποφυγή ηλεκτροπληξίας, φωτιάς ή τραυματισμού, εάν εντοπίσετε κάποια ανωμαλία όπως μυρωδιά φωτιάς, απενεργοποιήστε αμέσως την μονάδα και επικοινωνήστε αμέσως με τον προμηθευτή σας για οδηγίες.

**Μην επιτρέψετε να βραχεί η εσωτερική μονάδα ή το ασύρματο τηλεχειριστήριο.**

Μπορεί να προκληθεί ηλεκτροπληξία ή πυρκαγιά.

**Μην πιέζετε τα πλήκτρα του ασύρματου τηλεχειριστήριου με σκληρά αιχμηρά αντικείμενα.**

Μπορεί να προκληθεί βλάβη στο ασύρματο τηλεχειριστήριο.

**Μην αντικαθιστάτε φθαρμένη ασφάλεια με λάθος χωρητικότητα ασφάλεια ή με άλλα καλώδια.**

Η χρήση καλωδίων μπορεί να προκαλέσει βλάβη στη μονάδα ή να προκληθεί πυρκαγιά.

**Μην εκτείθετε το σώμα σας για μεγάλο χρονικό διάστημα στον αέρα που εξέρχεται από τη μονάδα, δεν είναι καλό για την υγεία σας.**

**Μην εισάγετε τα δάχτυλά σας ή άλλα αντικείμενα στις εισόδους και εξόδους του αέρα.**

Όταν ο ανεμιστήρας λειτουργεί στην μεγάλη ταχύτητα, θα προκληθεί τραυματισμός.

**Μην χρησιμοποιείται εύφλεκτα αέρια, όπως λακ ή μπογιά, κοντά στη μονάδα.**

Μπορεί να προκληθεί πυρκαγιά.

**Μην αγγίζετε την έξοδο του αέρα ή τις οριζόντιες περσίδες όταν η περσίδα του αέρα είναι σε λειτουργία.**

Μπορεί να πιαστούν τα δάχτυλά σας ή να προκληθεί βλάβη στη μονάδα.

**Μην τοποθετείτε αντικείμενα στις εισόδους και εξόδους του αέρα.**

Εάν έρθουν σε επαφή με τον ανεμιστήρα ενώ λειτουργεί σε μεγάλη ταχύτητα, υπάρχει σοβαρός κίνδυνος.

**Μην κάνετε εργασίες συντήρησης ή επισκευής μόνοι σας.**

Ζητήστε από κάποιο εξειδικευμένο προσωπικό να κάνει αυτές τις εργασίες.

**Μην απορρίπτετε αυτό το προϊόν μαζί με τα αστικά λύμματα. Θα πρέπει να γίνεται ξεχωριστή περισυλλογή για ειδική επεξεργασία.**

Μην απορρίπτετε τις ηλεκτρικές συσκευές μαζί με τα αστικά λύμματα. Επικοινωνήστε με την τοπική αυτοδιοίκηση σχετικά με τα ειδικά συστήματα περισυλλογής αυτών των συσκευών.

**Εάν οι ηλεκτρικές συσκευές απορριφθούν σε χωματερή, επικίνδυνες ουσίες μπορεί να εισρεύσουν στο έδαφος, να επηρεάσουν την τροφική αλυσίδα, με αποτέλεσμα να προκληθεί βλάβη στην υγεία σας.**

**Για την αποφυγή διαρροής ψυκτικού υγρού απευθυνθείτε στον προμηθευτή σας.**

Όταν η μονάδα εγκατασταθεί και λειτουργεί σε μικρό χώρο, θα πρέπει δίνετε προσοχή για τυχόν διαρροή ψυκτικού υγρού. Μπορεί να επηρεαστεί το οξυγόνο που υπάρχει στον χώρο και να προκληθεί σοβαρό ατύχημα.

**Το ψυκτικό υγρό που ρέει μέσα στη μονάδα είναι ασφαλές και συνήθως δεν εμφανίζεται διαρροή.**

Εάν προκληθεί διαρροή ψυκτικού υγρού στον χώρο και έρθουν σε επαφή με αναθυμιάσεις καυστήρα, θερμαντικού σώματος ή κουζίνας μπορεί να δημιουργηθεί επιβλαβές αέριο.

**Απενεργοποιήστε όλες τις εύφλεκτες θερμαντικές συσκευές, αερίστε τον χώρο και επικοινωνήστε με τον προμηθευτή σας. Μην λειτουργήσετε τη μονάδα έως ότου ένας εξειδικευμένος τεχνικός σας βεβαιώσει ότι δεν υπάρχει πλέον διαρροή.**



### ΠΡΟΣΟΧΗ

**Μην χρησιμοποιείται την κλιματιστική μονάδα για άλλους σκοπούς.**

Μην χρησιμοποιείτε τη μονάδα για την ψύξη τροφίμων, φυτών, ζώων κλπ, για την αποφυγή φθοράς.

**Πριν το καθαρισμό, απενεργοποιήστε τη μονάδα και κατεβάστε την ασφάλεια ή αποσυνδέστε την από την πρίζα.**

Σε αντίθετη περίπτωση μπορεί να προκληθεί ηλεκτροπληξία ή πυρκαγιά.

**Για την αποφυγή ηλεκτροπληξίας ή πυρκαγιάς, βεβαιωθείτε ότι έχει τοποθετηθεί ρελέ διαφυγής.**

**Βεβαιωθείτε πως στην κλιματιστική μονάδα έχει εγκατασταθεί γείωση.**

Για την αποφυγή ηλεκτροπληξίας, βεβαιωθείτε πως η μονάδα είναι γειωμένη και πως το καλώδιο γείωσης δεν είναι συνδεδεμένο σε σωλήνα αερίου ή νερού, αγωγό φωτισμού ή σε τηλεφωνικό καλώδιο.

**Για την αποφυγή τραυματισμού, μην αφαιρείτε το πλέγμα του ανεμιστήρα της εξωτερικής μονάδας.**

**Μην λειτουργείτε τη μονάδα με βρεγμένα χέρια.**  
Μπορεί να προκληθεί ηλεκτροπληξία.

**Μην αγγίζετε τα πτερύγια του εναλλάκτη θερμότητας.**  
Τα πτερύγια αυτά είναι αιχμηρά και μπορεί να κοπείτε.

**Μην τοποθετείτε κάτω από την εσωτερική μονάδα αντικείμενα που μπορεί να φθαρούν από υγρασία.**  
Μπορεί να σχηματιστεί υγρασία εάν η υγρασία είναι πάνω από 80%, έχει φραγεί ο αγωγός αποστράγγισης ή είναι φραγμένο το φίλτρο.

**Μετά από μεγάλο διάστημα χρήσης, ελέγξτε τη βάση και τα στηρίγματα της μονάδας για φθορές.**  
Εάν υπάρχει φθορά, η μονάδα μπορεί να πέσει και να προκληθεί τραυματισμός.

**Για να αποφύγετε έλλειψη οξυγόνου, να αερίζετε επαρκώς τον χώρο εάν παράλληλα με την κλιματιστική μονάδα χρησιμοποιείτε και κάποια θερμαντική συσκευή.**

**Τοποθετήστε σωστά τον αγωγό αποστράγγισης για την εξασφάλιση ομαλής απορροής συμπυκνωμάτων.**  
Ανεπαρκής αποστράγγιση μπορεί να έχει ως αποτέλεσμα να βραχούν οι τοίχοι ή τα έπιπλα.

**Μην αγγίζετε τα εσωτερικά μέρη της μονάδας.**  
Μην αφαιρείτε το μπροστινό πάνελ. Κάποια από τα εσωτερικά μέρη είναι επικίνδυνα και μπορεί να προκληθεί κάποια βλάβη στη μονάδα.

**Μην εκτείθετε απευθείας μικρά παιδιά, φυτά ή ζώα στη ροή του αέρα.**  
Μπορεί να υπάρξει επιβλαβής επιρροή πάνω τους.

**Μην επιτρέπετε στα παιδιά να ανεβαίνουν πάνω στην εξωτερική μονάδα και μην τοποθετείτε αντικείμενα πάνω σε αυτή.**  
Πιθανή πτώση μπορεί να προκαλέσει τραυματισμό.

**Μην λειτουργείτε τη μονάδα όταν χρησιμοποιείτε θειούχα αέρια, όπως εντομοκτόνο.**  
Μπορεί οι χημικές ουσίες να απορροφηθούν από τη μονάδα, με αποτέλεσμα να μπει σε κίνδυνο η υγεία ατόμων που είναι υπερευαίσθητα σε αυτές.

**Μην τοποθετείτε συσκευές που παράγουν φλόγα σε σημείο που είναι εκτεθειμένες στην ροή του αέρα ή κάτω από την εσωτερική μονάδα.**  
Μπορεί να προκληθεί ανεπαρκής ανάφλεξη ή παραμόρφωση της μονάδας εξαιτίας του θερμού εξερχόμενου αέρα.

**Μην τοποθετείτε την κλιματιστική μονάδα σε οποιοδήποτε μέρος μπορεί να διαρρεύσει εύφλεκτο αέριο.**  
Εάν υπάρξει διαρροή αερίου και παραμένει κοντά στην μονάδα, μπορεί να προκληθεί πυρκαγιά.

**Η μονάδα δεν είναι σχεδιασμένη να χρησιμοποιείται από παιδιά ή άτομα με ειδικές ανάγκες χωρίς επίβλεψη.**

**Μην λειτουργείτε την μονάδα σε χώρους με υψηλή υγρασία, όπως μπάνια.**

**Η μονάδα επιτρέπεται να λειτουργείται από παιδιά άνω των 8 ετών, άτομα με μειωμένη σωματική και πνευματική ικανότητα ή έλλειψη εμπειρίας και γνώσης, μόνο όταν τους έχουν δοθεί σαφείς οδηγίες για την ασφαλή λειτουργία της μονάδας και υπάρχει άτομο που τα επιβλέπει. Τα παιδιά δεν πρέπει να παίζουν με την μονάδα. Καθαρισμός και οποιαδήποτε συντήρηση δεν θα πρέπει να γίνεται από παιδιά.**

Η μονάδα δεν θα πρέπει να λειτουργείται από άτομα με ειδικές ανάγκες και παιδιά ή άτομα με έλλειψη γνώσης και εμπειρίας, παρά μόνο αν επιβλέπονται από κατάλληλο άτομο υπεύθυνο για την ασφάλειά τους.

Τα παιδιά θα πρέπει να επιβλέπονται ώστε να μην παίζουν με την μονάδα.

Εάν το καλώδιο τροφοδοσίας έχει φθαρεί θα πρέπει να αντικατασταθεί είτε από τον κατασκευαστή είτε από εξειδικευμένο προσωπικό για την αποφυγή τραυματισμού.

## 2. ΟΜΟΜΑΤΟΛΟΓΙΑ

**Η κλιματιστική μονάδα αποτελείται από την εσωτερική, την εξωτερική, τον σωλήνα σύνδεσης και το ασύρματο τηλεχειριστήριο. (Ανατρέξτε στην εικ. 2-1)**

**Λειτουργία ενδείξεων στην οθόνη της εσωτερικής μονάδας.**

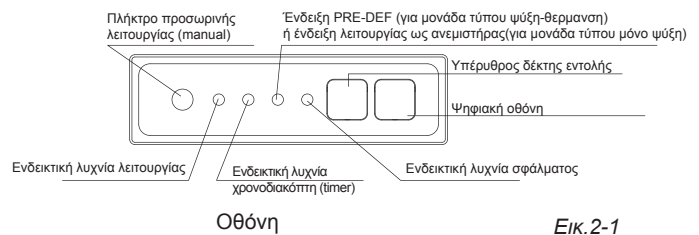

Για inverter μονάδες το πλήκτρο προσωρινής λειτουργίας θα πρέπει να χρησιμοποιείται μόνο για εργασίες συντήρησης, ο χρήστης δεν πρέπει να το χρησιμοποιεί.

Για μονάδες σταθερών στροφών το πλήκτρο προσωρινής λειτουργίας (manual) χρησιμοποιείται σε περίπτωση που χαθεί το ασύρματο τηλεχειριστήριο ή εξαντληθούν οι μπαταρίες του. Μέσω του πλήκτρου προσωρινής λειτουργίας (manual) μπορεί να επιλεγεί είτε η εξαναγκασμένη αυτόματη λειτουργία (FORCED AUTO) είτε εξαναγκασμένη ψύξη (FORCED COOL). Όταν πιέσετε αυτό το πλήκτρο, η μονάδα θα λειτουργήσει με την εξής σειρά: Εξαναγκασμένη αυτόματη λειτουργία (FORCED AUTO), Εξαναγκασμένη Ψύξη (FORCED COOL), OFF και μετά πάλι σε εξαναγκασμένη αυτόματη λειτουργία FORCED AUTO.

1. Εξαναγκασμένη αυτόματη λειτουργία (FORCED AUTO)  
Η ενδεικτική λυχνία λειτουργίας είναι αναμμένη και η κλιματιστική μονάδα θα τεθεί σε αυτόματη λειτουργία (FORCED AUTO). Η λειτουργία του ασύρματου τηλεχειριστηρίου ενεργοποιείται σύμφωνα με την λαμβανόμενη εντολή.

2. Εξαναγκασμένη Ψύξη (FORCED COOL)  
Η ενδεικτική λυχνία λειτουργίας αναβοσβήνει και η μονάδα θα επιστρέψει σε αυτόματη κατάσταση λειτουργίας (AUTO), αφού έχει λειτουργήσει σε ψύξη για 30 λεπτά στη μεγάλη ταχύτητα ανεμιστήρα. Η λειτουργία του ασύρματου τηλεχειριστηρίου είναι απενεργοποιημένη.

3. OFF  
Η ενδεικτική λυχνία σβήνει. Η κλιματιστική μονάδα παραμένει απενεργοποιημένη μέχρι να επανέλθει η λειτουργία του ασύρματου τηλεχειριστηρίου.



### ΣΗΜΕΙΩΣΗ

Αυτό το εγχειρίδιο δεν περιλαμβάνει οδηγίες για το ασύρματο τηλεχειριστήριο. Ανατρέξτε στο αντίστοιχο εγχειρίδιο που συνοδεύει τη μονάδα.

### 3. ΛΕΙΤΟΥΡΓΙΕΣ ΤΗΣ ΚΛΙΜΑΤΙΣΤΙΚΗΣ ΜΟΝΑΔΑΣ

Να λειτουργείτε τη μονάδα στις παρακάτω θερμοκρασίες για ασφαλή και αποδοτική λειτουργία. Η μέγιστη θερμοκρασία λειτουργίας για την κλιματιστική μονάδα. (Ψύξη/Θέρμανση)

Πίνακας 2-1

Θερμοκρασία Λειτουργία	Εξωτερική θερμοκρασία	Θερμοκρασία χώρου
Λειτουργία ψύξης	18°C ~ 43°C / 64 °F~109°F	17°C ~ 32°C (62 °F ~ 90°F)
	-7°C ~ 43°C / 20 °F~109°F (για μοντέλα με δυνατότητα ψύξης σε χαμηλές εξωτερικές θερμοκρασίες)	
	18°C ~ 52°C / 64 °F~126°F (για ειδικά μοντέλα σχεδιασμένα για τροπικές συνθήκες)	
Λειτουργία θέρμανσης (Οι μονάδες μόνο ψύξη δεν τη διαθέτουν)	-7°C ~ 24°C / 20 °F ~ 76°F	0°C ~ 30°C / 32 °F~86°F
Λειτουργία αφύγρανσης	18°C ~ 43°C / 64 °F~109°F	17°C ~ 32°C (62 °F ~ 90°F)
	18°C ~ 52°C / 64 °F~126°F (για ειδικά μοντέλα σχεδιασμένα για τροπικές συνθήκες)	

Πίνακας 2-2 (Για Inverter κλιματιστικές μονάδες)

Θερμοκρασία Λειτουργία	Outdoor temperature	Room temperature
Λειτουργία ψύξης	0°C ~ 50°C / 32 °F~122°F	17°C~32°C (62°F ~90°F)
	-15°C ~ 50°C / 5 °F~122°F (για μοντέλα με δυνατότητα ψύξης σε χαμηλές εξωτερικές θερμοκρασίες)	
Λειτουργία θέρμανσης (Οι μονάδες μόνο ψύξη δεν τη διαθέτουν)	-15°C ~ 24°C / 5 °F~76°F	0°C~30°C (32°F~86°F)
Λειτουργία αφύγρανσης	0°C ~ 50°C / 32 °F~122°F	17°C~32°C (62°F ~90°F)



#### ΣΗΜΕΙΩΣΗ

- Εάν η κλιματιστική μονάδα λειτουργεί εκτός των ανωτέρω συνθηκών, μπορεί να προκαλέσει την μη ομαλή λειτουργία της μονάδας.
- Εάν η σχετική υγρασία στον χώρο είναι υψηλή, είναι φυσιολογικό να εμφανιστούν συμπυκνώματα στην επιφάνεια της κλιματιστικής μονάδας. Παρακαλούμε κλείστε την πόρτα και το παράθυρο.
- Η βέλτιστη απόδοση επιτυγχάνεται εντός αυτού του εύρους θερμοκρασιών λειτουργίας.

### 3-λεπτη προστασία

Εάν ενεργοποιήσετε τη μονάδα αμέσως μετά από την απενεργοποίηση της, δεν θα αρχίσει να λειτουργεί αν δεν περάσουν περίπου 3 λεπτά.

### Διακοπή Ρεύματος

Μια διακοπή ρεύματος κατά τη λειτουργία της μονάδας, θα σταματήσει τη μονάδα.

- Όταν το ρεύμα επανέλθει, η ενδεικτική λυχνία λειτουργίας στην εσωτερική μονάδα θα αρχίσει να αναβοσβήνει
- Για επαναλειτουργία της μονάδας πιέστε το πλήκτρο ON/OFF στο ασύρματο τηλεχειριστήριο.
- Η ύπαρξη διακοπή φωτισμού ή η χρήση κινητού τηλεφώνου κοντά στη μονάδα μπορεί να προκαλέσει βλάβη.

### 4. ΣΥΜΒΟΥΛΕΣ ΓΙΑ ΟΙΚΟΝΟΜΙΚΗ ΛΕΙΤΟΥΡΓΙΑ

Για την εξασφάλιση οικονομικής λειτουργίας θα πρέπει να ληφθούν υπόψη τα παρακάτω.

(Ανατρέξτε στο αντίστοιχο κεφάλαιο για λεπτομέρειες)

- Ρυθμίστε κατάλληλα την κατεύθυνση ροής ώστε να αποφύγετε την απευθείας έκθεση του σώματός σας στη ροή του αέρα.
- Ρυθμίστε κατάλληλα την θερμοκρασία του χώρου ώστε να υπάρχει ευχάριστο περιβάλλον και να αποφύγετε την υπερβολική ψύξη ή θέρμανση.
- Όταν λειτουργείτε τη μονάδα σε ψύξη, κλείστε τις κουρτίνες για να εμποδίσετε την ηλιακή ακτινοβολία να εισέλθει στον χώρο.
- Για να διατηρήσετε τον κρύο ή ζεστό αέρα μέσα στον χώρο, μην ανοίγετε συχνότερα από ότι χρειάζεται πόρτες και παράθυρα.
- Ρυθμίστε τον χρονοδιακόπτη (timer) για να ορίσετε το επιθυμητό διάστημα λειτουργίας.
- Μην τοποθετείτε εμπόδια κοντά στις εξόδους ή στις εισόδους του αέρα. Μπορεί να προκληθεί μείωση στην απόδοση της μονάδας ή ακόμα και την ξαφνική παύση λειτουργίας της.
- Εάν δεν σκοπεύετε να χρησιμοποιήσετε τη μονάδα για αρκετό χρονικό διάστημα, αποσυνδέστε τη μονάδα από την παροχή ρεύματος και αφαιρέστε τις μπαταρίες από το ασύρματο τηλεχειριστήριο. Εάν παραμείνει συνδεδεμένη η ασφάλεια καταναλώνεται ενέργεια ακόμα και αν η μονάδα δεν λειτουργεί. Επομένως αποσυνδέστε τη μονάδα για εξοικονόμηση ενέργειας. Όταν θα θέλετε να επαναλειτουργήσετε τη μονάδα, παρακαλούμε επανασυνδέστε την παροχή 12 ώρες πριν την εκκίνηση, ώστε να επιτευχθεί ομαλή λειτουργία.
- Ένα φραγμένο φίλτρο μπορεί να προκαλέσει μείωση της ψυκτικής ή θερμικής απόδοσης. Να καθαρίζετε τα φίλτρα κάθε 15 μέρες.

### 5. ΣΥΝΤΗΡΗΣΗ



#### ΠΡΟΣΟΧΗ

Βεβαιωθείτε πως έχετε αποσυνδέσει τη μονάδα από την παροχή ρεύματος πριν την καθαρίσετε.

Ελέγξτε εάν το καλώδιο είναι φθαρμένο ή αποσυνδεδεμένο.

Χρησιμοποιείτε ένα στεγνό πανί για να σκουπίσετε την εσωτερική μονάδα και το ασύρματο τηλεχειριστήριο.

Εάν η μονάδα είναι πολύ βρώμικη χρησιμοποιήστε ένα βρεγμένο πανί για να την καθαρίσετε.

Μην χρησιμοποιείτε βρεγμένο πανί για το ασύρματο τηλεχειριστήριο.

Μην χρησιμοποιείτε ξεσκονόπανο χημικά επεξεργασμένο και μην αφήνετε τέτοιου τύπου υλικά πάνω στη μονάδα για αρκετό χρονικό διάστημα. Μπορεί να προκληθεί φθορά στην επιφάνεια της μονάδας.

Μην χρησιμοποιείτε βενζίνη, διαλυτικά, στιλβωτικά ή διάφορα παρόμοια διαλύματα για τον καθαρισμό της μονάδας. Μπορεί να προκληθεί ράγιγμα ή παραμόρφωση στην πλαστική επιφάνεια της μονάδας.



## ■ Συντήρηση στην έναρξη της περιόδου λειτουργίας

Ελέγξτε και απομακρύνετε οτιδήποτε μπορεί να εμποδίζει τις εισόδους και εξόδους του αέρα της εσωτερικής και εξωτερικής μονάδας.

Καθαρίστε τα φίλτρα και τα καλύμματα της εσωτερικής μονάδας. Ανατρέξτε το εδάφιο "Καθαρισμός του φίλτρου αέρα" για τον τρόπο καθαρισμού και για να βεβαιωθείτε πως έχετε επανατοποθετήσει τα φίλτρα σωστά.

Συνδέστε την παροχή ρεύματος τουλάχιστον 12 ώρες πριν ενεργοποιήσετε τη μονάδα για να εξασφαλίσετε την ομαλή της λειτουργία. Μόλις συνδεθεί η παροχή θα εμφανιστούν και οι ενδείξεις του ασύρματου χειριστηρίου.

## ■ Συντήρηση πριν το τέλος της περιόδου λειτουργίας

Ρυθμίστε τη μονάδα να λειτουργήσει με την επιλογή ανεμιστήρα (fan) για μισή μέρα περίπου ώστε να απομακρυνθεί η υγρασία από το εσωτερικό της μονάδας.

Καθαρίστε τα φίλτρα και τα καλύμματα της εσωτερικής μονάδας. Ανατρέξτε το εδάφιο "Καθαρισμός του φίλτρου αέρα" για τον τρόπο καθαρισμού και για να βεβαιωθείτε πως έχετε επανατοποθετήσει τα φίλτρα σωστά.

## ■ Καθαρισμός του φίλτρου αέρα (σε ορισμένα μοντέλα)

Το φίλτρο αέρα εμποδίζει την είσοδο σκόνης ή άλλων σωματιδίων στο εσωτερικό της μονάδας. Εάν υπάρχει φραγμένο φίλτρο μπορεί να μειωθεί σημαντικά ή απόδοση της μονάδας. Επομένως, το φίλτρο θα πρέπει κατά την περίοδο λειτουργίας να καθαρίζεται κάθε 15 ημέρες.

Εάν η μονάδα είναι εγκατεστημένη σε περιβάλλον επιβαρυσμένο από σκόνη, τότε το φίλτρο να καθαρίζεται συχνότερα.

Εάν η συσσωρευμένη σκόνη είναι δύσκολο να καθαριστεί, τότε αντικαταστήστε το φίλτρο.

Ο καθαρισμός των φίλτρων θα πρέπει να γίνεται από εξειδικευμένο προσωπικό.

- Εάν η μονάδα που αγοράσατε έχει πλαινό αερισμό, αφαιρέστε τις 2 βίδες που υπάρχουν στο φίλτρο και αφαιρέστε το φίλτρο από τη μονάδα.

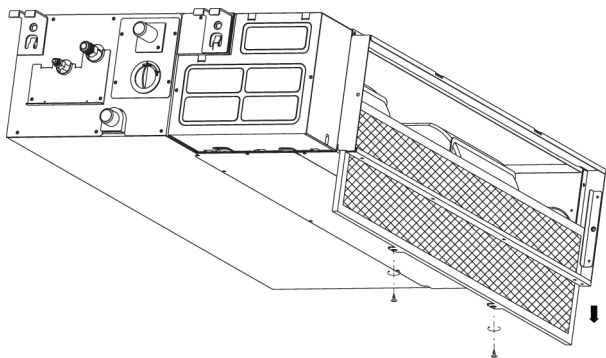

Εικ. 5-1

- Εάν η μονάδα που αγοράσατε είναι με αερισμό από κάτω, πιέστε το φίλτρο ελαφρώς προς τα πάνω ώστε ο σφιγκτήρας να βγει από τις οπές και αφαιρέστε τα φίλτρα σύμφωνα με τη φορά που δείχνουν τα βέλη στην παρακάτω εικόνα.

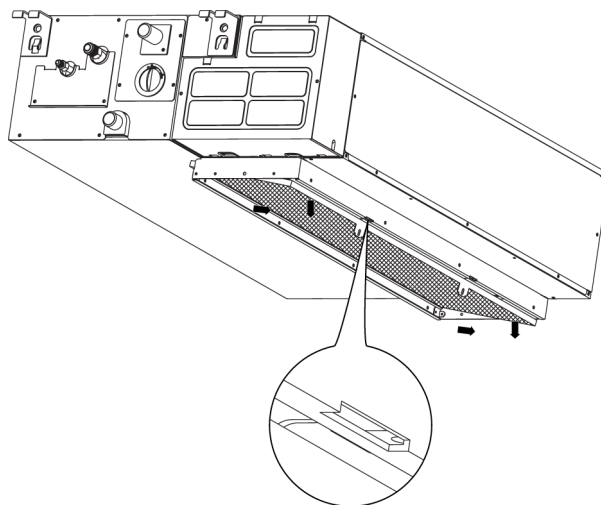

Εικ. 5-2

- Καθαρίστε το φίλτρο αέρα (Μπορείτε να χρησιμοποιήσετε ηλεκτρική σκούπα ή καθαρό νερό. Εάν υπάρχει πολλή συσσωρευμένη σκόνη, χρησιμοποιήστε μαλακή βούρτσα και ουδέτερο απορρυπαντικό για τον καθαρισμό και στεγνώστε το σε σκιερό μέρος).

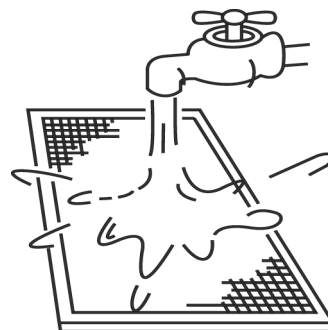

Εικ. 5-3

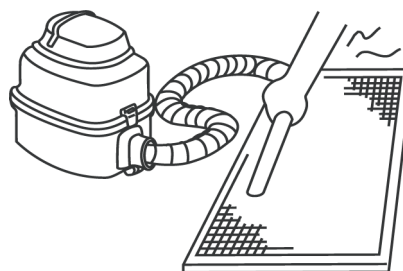

Εικ. 5-4

Η πλευρά προσαγωγής του αέρα πρέπει να είναι προς τα πάνω όταν χρησιμοποιείτε ηλεκτρική σκούπα.  
(Ανατρέξτε στην εικ. 5-4)

Η πλευρά προσαγωγής του αέρα πρέπει να είναι προς τα κάτω όταν χρησιμοποιείτε νερό.  
(Ανατρέξτε στην εικ. 5-3)



## ΠΡΟΣΟΧΗ

Μην στεγνώνετε το φίλτρο αέρα στον ήλιο ή κοντά σε φωτιά.

- Επανατοποθετήστε το φίλτρο αέρα.
- Τοποθετήστε και κλείστε το πλέγμα της εισόδου αέρα με την αντίστροφη σειρά των βημάτων 1 και 2 και συνδέστε τα καλώδια στις αντίστοιχες επαφές.

## 6. ΤΑ ΠΑΡΑΚΑΤΩ ΣΥΜΠΤΩΜΑΤΑ ΔΕΝ ΑΠΟΤΕΛΟΥΝ ΣΦΑΛΜΑΤΑ ΤΗΣ ΚΛΙΜΑΤΙΣΤΙΚΗΣ ΜΟΝΑΔΑΣ

### Σύμπτωμα 1: Η μονάδα δεν λειτουργεί

- Πιέσατε το πλήκτρο ON/OFF στο ασύρματο τηλεχειριστήριο αλλά η μονάδα δεν ξεκίνησε αμέσως να λειτουργεί. Εάν η ενδεικτική λυχνία λειτουργίας είναι αναμμένη, τότε η κατάσταση λειτουργίας είναι ομαλή. Για την αποφυγή υπερφόρτωσης του συμπιεστή, η μονάδα δεν ξεκινάει τη λειτουργία αν δεν παρέλθουν 3 λεπτά από την ενεργοποίηση της.
- Εάν η ενδεικτική λυχνία λειτουργίας και η ένδειξη "PRE-DEF" (για τύπου αντλία θερμότητας) ή ένδειξη ανεμιστήρας (για τύπο μόνο ψύξη) είναι αναμμένες, σημαίνει ότι έχετε επιλέξει λειτουργία θέρμανσης. Κατά την εκκίνηση, εάν ο συμπιεστής δεν έχει ξεκινήσει, η εσωτερική μονάδα ενεργοποιεί την προστασία έναντι εξόδου κρύου αέρα, διότι είναι χαμηλότερη από την εξωτερική θερμοκρασία.

### Σύμπτωμα 2: Αλλαγή σε λειτουργία ανεμιστήρα κατά τη διάρκεια λειτουργίας σε ψύξη.

- Για την αποφυγή σχηματισμού πάγου στο στοιχείο της εσωτερικής μονάδας, η μονάδα αλλάζει αυτόματα σε λειτουργία ανεμιστήρα για λίγο και επανέρχεται σε κατάσταση ψύξης.
- Όταν η θερμοκρασία του χώρου φτάσει στην επιθυμητή, συμπιεστής σταματάει και η μονάδα αλλάζει σε λειτουργία ανεμιστήρα. Όταν η θερμοκρασία ανέβει ο συμπιεστής ξαναρχίζει να λειτουργεί. Το ίδιο συμβαίνει και κατά τη λειτουργία στην θέρμανση.

### Σύμπτωμα 3: Εξέρχεται από τη μονάδα λευκή ομίχλη

#### Σύμπτωμα 3.1: Εσωτερική μονάδα

- Όταν κατά τη λειτουργία της μονάδας σε ψύξη η υγρασία είναι υψηλή. Εάν το εσωτερικό εσωτερικό της μονάδας είναι πολύ βρώμικο, η κατανομή της θερμοκρασίας στον χώρο δεν είναι ομαλή. Είναι απαραίτητο να γίνει καθαρισμός στο εσωτερικό της μονάδας. Επικοινωνήστε με τον προμηθευτή σας σχετικά με τον καθαρισμό της μονάδας. Αυτή η εργασία πρέπει να γίνει από εξειδικευμένο προσωπικό.

### Σύμπτωμα 3.2: Εσωτερική, εξωτερική μονάδα.

- Όταν η μονάδα επανέλθει σε λειτουργία θέρμανσης μετά από αποπύκνωση. Η υγρασία που σχηματίζεται από το λιώσιμο του πάγου μετασχηματίζεται σε ατμό και εξατμίζεται.

### Σύμπτωμα 4: Θόρυβος κατά τη λειτουργία σε ψύξη

#### Σύμπτωμα 4.1: Εσωτερική μονάδα

- Κατά τη λειτουργία της μονάδας σε ψύξη ή όταν σταματάει ακούγεται ένας βαθύς συνεχόμενος ήχος. Πρόκειται για τον ήχο των συμπυκνωμάτων όταν ρέουν μέσα από τον αγωγό αποστράγγισης.
- Όταν η μονάδα απενεργοποιείται μετά από λειτουργία σε θέρμανση, ακούγεται ένα τρίξιμο. Πρόκειται για τον ήχο των πλαστικών μερών της μονάδας που προκαλείται από διαστολές και συστολές.

#### Σύμπτωμα 4.2: Εσωτερική εξωτερική μονάδα

- Όταν η μονάδα λειτουργεί ακούγεται ένας βαθύς συνοχόμενος ήχος. Πρόκειται για τον ήχο που προκαλείται από την ροή του ψυκτικού υγρού στην εσωτερική και εξωτερική μονάδα.
- Κατά την ενεργοποίηση ή απενεργοποίηση της μονάδας ή μετά την ολοκλήρωση της αποπύκνωσης ακούγεται ένας βαθύς ήχος. Είναι ο ήχος που προκαλείτε όταν σταματά ή αλλάζει η ροή του ψυκτικού υγρού.

#### Σύμπτωμα 4.3: Εξωτερική μονάδα

- Όταν αλλάζει ο θόρυβος που παράγει η εξωτερική μονάδα. Προκαλείται από την αλλαγή της συχνότητας.

### Σύμπτωμα 5: Εξέρχεται σκόνη από τη μονάδα

- Όταν η μονάδα λειτουργεί για πρώτη φορά μετά από μεγάλο χρονικό διάστημα. Προκαλείται διότι έχει έχει εισέλθει σκόνη στη μονάδα.

### Σύμπτωμα 6: Αναδύονται οσμές από τη μονάδα

- Η μονάδα μπορεί να απορροφήσει μυρωδιές από τον χώρο, τα έπιπλα, τσιγάρα κλπ, τις απορίες έπειτα αποβάλλει.

### Σύμπτωμα 7: Ο ανεμιστήρας της εξωτερικής μονάδας δεν περιστρέφεται

- Κατά τη λειτουργία. Η ταχύτητα του ανεμιστήρα ρυθμίζεται ώστε να επιτευχθεί η βέλτιστη λειτουργία της μονάδας.

## 7. ΑΝΤΙΜΕΤΩΠΙΣΗ ΠΡΟΒΛΗΜΑΤΩΝ

### 7.1 Προβλήματα και αιτίες που τα δημιουργούν.

Εάν εμφανιστεί κάποια από τις παρακάτω δυσλειτουργίες, σταματήστε αμέσως τη λειτουργία της μονάδας, αποσυνδέστε τη από την παροχή ρεύματος και επικοινωνήστε με τον προμηθευτή σας.

- Η ενδεικτική λυχνία λειτουργίας αναβοσβήνει γρήγορα (5Hz) και το πρόβλημα παραμένει αν κάνετε επανεκκίνηση στη μονάδα. (Ανατρέξτε στον πίνακα 7-1α, πίνακα 7-1β και πίνακα 7-2)
- Το ασύρματο τηλεχειριστήριο δεν λειτουργεί σωστά.
- Η ασφάλεια ή ο διακόπτης ενεργοποιούνται συχνά.
- Εισήλθε νερό ή κάποιο αντικείμενο στη μονάδα
- Υπάρχει διαρροή νερού από την εσωτερική μονάδα.
- Άλλες δυσλειτουργίες

Εάν η μονάδα δεν λειτουργεί σωστά, εκτός από τις ανωτέρω περιπτώσεις, παρακαλούμε κάνετε τους ελέγχους που αναφέρονται παρακάτω. (Ανατρέξτε στον πίνακα 7-3)



#### ΠΡΟΣΟΧΗ

Όταν εμφανιστεί κάποιο από τα παραπάνω σφάλματα, αποσυνδέστε τη μονάδα από την παροχή ρεύματος, ελέγξτε εάν η τάση του δικτύου είναι η σωστή, ελέγξτε ότι η εγκατάσταση της μονάδας έχει γίνει σωστά και ενεργοποιήστε τη μονάδα αφού παρέλθουν τουλάχιστον 3 λεπτά. Εάν το πρόβλημα παραμείνει, παρακαλούμε επικοινωνήστε με τον προμηθευτή σας.



---

A/A	ΠΕΡΙΓΡΑΦΗ ΣΦΑΛΜΑΤΟΣ	LED 1 ΛΕΙΤΟΥΡΓΙΑ	LED 2 ΧΡΟΝΟΔΙΑΚΟΠΤΗΣ (TIMER)	LED 3 DEF.FAN	LED 4 ΠΡΟΕΙΔΟΠΟΙΗΣΗ (ALARM)	ΕΝΔΕΙΞΗ ΣΤΗΝ ΟΘΟΝΗ
1	Σφάλμα στον έλεγχο του μοτέρ ανεμιστήρα της εσωτερικής μονάδας					E8
2	Σφάλμα στην επικοινωνία της εσωτερικής με την εξωτερική μονάδα.					E1
3	Σφάλμα στον αισθητήρα θερμοκρασίας χώρου					E2
4	Σφάλμα στον αισθητήρα θερμοκρασίας στοιχείου (T2)					E3
5	Σφάλμα στον αισθητήρα θερμοκρασίας στοιχείου (T2B)					E4
6	Σφάλμα λογισμικού					E7
7	Προειδοποίηση στάθμης νερού					EE
8	Σφάλμα στην εξωτερική μονάδα					Ed
9	Σφάλμα επικοινωνίας μεταξύ του ζεύγους εσωτερικών μονάδων					F3
10	Άλλη δυσλειτουργία στο ζεύγος των εσωτερικών					F4

Αναμμένο     
 Αναβοσβήνει στα 2.5 Hz     
 Αναβοσβήνει στα 0.5 Hz

**Μόνο για Inverter κλιματιστικές μονάδες**

A/A	ΠΕΡΙΓΡΑΦΗ ΣΦΑΛΜΑΤΟΣ	LED 1 ΛΕΙΤΟΥΡΓΙΑ	LED 2 ΧΡΟΝΟΔΙΑΚΟΠΤΗΣ (TIMER)	LED 3 DEF.FAN	LED 4 ΠΡΟΕΙΔΟΠΟΙΗΣΗ (ALARM)	ΕΝΔΕΙΞΗ ΣΤΗΝ ΟΘΟΝΗ
•	Σφάλμα στον αισθητήρα θερμοκρασίας χώρου		○			E 2
•	Σφάλμα στον αισθητήρα θερμοκρασίας στοιχείου	○				E 3
•	Σφάλμα στον αισθητήρα θερμοκρασίας εξωτερικού περιβάλλοντος			○		E 4
•	Σφάλμα στην εξωτερική μονάδα	○	○	○	○	E 6
•	Σφάλμα στον αισθητήρα της αντλίας συμπυκνωμάτων				○	E 5
•	Σφάλμα λογισμικού	○	○			E 7
•	Προειδοποίηση στάθμης νερού				○	E 8
•	Σφάλμα στον έλεγχο της ταχύτητας του DC μοτέρ		○		○	Eb
•	Προστασία λόγω χαμηλής πίεσης στην εξωτερική μονάδα	○	○	○		Ed

 Αναμμένο
  Αναβοσβήνει στα 5 Hz
  Αναβοσβήνει στο 1 Hz

**Μόνο για κλιματιστικές μονάδες σταθερών στροφών**

Συμπτώματα	Αιτίες	Επίλυση
<b>Η μονάδα δεν εκκινεί</b>	<ul style="list-style-type: none"> <li>• Διακοπή ρεύματος</li> <li>• Ο διακόπτης παροχής ρεύματος είναι σε θέση off</li> <li>• Έχει καεί η ασφάλεια του διακόπτη παροχής ρεύματος</li> <li>• Έχουν εξαντληθεί οι μπαταρίες του ασύρματου τηλεχειριστηρίου ή υπάρχει σφάλμα στο ίδιο το χειριστήριο</li> </ul>	<ul style="list-style-type: none"> <li>• Περιμένετε να επανασυνδεθεί το ρεύμα</li> <li>• Θέστε τον διακόπτη ρεύματος σε θέση on</li> <li>• Αντικαταστήστε την καμένη ασφάλεια</li> <li>• Αντικαταστήστε τις μπαταρίες ή ελέγξτε το χειριστήριο</li> </ul>
<b>Ενώ υπάρχει ροή αέρα η μονάδα δεν βγάζει ψύξη</b>	<ul style="list-style-type: none"> <li>• Η επιλεγμένη θερμοκρασία δεν είναι η σωστή</li> <li>• Η μονάδα έχει ενεργοποιημένη την προστασία 3 λεπτών</li> </ul>	<ul style="list-style-type: none"> <li>• Ρυθμίστε σωστά την θερμοκρασία</li> <li>• Περιμένετε</li> </ul>
<b>Η μονάδα ξεκινάει ή σταματάει συχνά</b>	<ul style="list-style-type: none"> <li>• Η ποσότητα του ψυκτικού υγρού είναι ελλιπής είναι πολλή περισσότερη.</li> <li>• Υπάρχει αέρας ή μη συμπανές αέριο στο ψυκτικό κύκλωμα</li> <li>• Δυσλειτουργία του συμπιεστή</li> <li>• Η τάση είναι πολύ χαμηλή ή πολύ υψηλή</li> <li>• Το κύκλωμα της μονάδας είναι φραγμένο</li> </ul>	<ul style="list-style-type: none"> <li>• Ελέγξτε για διαρροές και πληρώστε σωστά ψυκτικό υγρό</li> <li>• Αδειάστε και επαναπληρώστε ψυκτικό υγρό</li> <li>• Επισκευάστε ή αντικαταστήστε τον συμπιεστή</li> <li>• Εγκαταστήστε σταθεροποιητή τάσης</li> <li>• Βρείτε τις αιτίες και τη λύση</li> </ul>
<b>Μειωμένη ψυκτική απόδοση</b>	<ul style="list-style-type: none"> <li>• Το στοιχείο της εσωτερικής και εξωτερικής μονάδας είναι βρώμικο</li> <li>• Το φίλτρο αέρα είναι βρώμικο</li> <li>• Είναι φραγμένη η είσοδος/έξοδος της εσωτερικής/ εξωτερικής μονάδας</li> <li>• Υπάρχουν πόρτες και παράθυρα ανοιχτά</li> <li>• Απευθείας ηλιακή ακτινοβολία στον χώρο</li> <li>• Υπάρχουν στον χώρο πολλές πηγές θερμότητας</li> <li>• Η εξωτερική θερμοκρασία περιβάλλοντος είναι πολλή υψηλή</li> <li>• Υπάρχει διαρροή ή έλλειψη ψυκτικού υγρού</li> </ul>	<ul style="list-style-type: none"> <li>• Καθαρίστε το στοιχείο</li> <li>• Καθαρίστε το φίλτρο</li> <li>• Απομακρύνετε όλες τις ακαθαρσίες για να γίνει ομαλή η ροή αέρα</li> <li>• Κλείστε πόρτες και παράθυρα</li> <li>• Κλείστε τις κουρτίνες</li> <li>• Μειώστε τις πηγές θερμότητας στον χώρο</li> <li>• Η απόδοση της μονάδας μειώνεται (φυσιολογικό)</li> <li>• Ελέγξτε για διαρροές και επαναπληρώστε σωστά ψυκτικό υγρό.</li> </ul>
<b>Μειωμένη θερμική απόδοση</b>	<ul style="list-style-type: none"> <li>• Η εξωτερική θερμοκρασία περιβάλλοντος είναι κάτω από 7°C</li> <li>• Οι πόρτες και τα παράθυρα δεν είναι τελείως κλειστά</li> <li>• Υπάρχει διαρροή ή έλλειψη ψυκτικού υγρού</li> </ul>	<ul style="list-style-type: none"> <li>• Χρησιμοποιήστε θερμαντικό σώμα</li> <li>• Κλείστε πόρτες και παράθυρα</li> <li>• Ελέγξτε για διαρροές και επαναπληρώστε σωστά ψυκτικό υγρό.</li> </ul>

## 7.2 Δυσλειτουργίες του ενσύρματου χειριστηρίου και αιτίες

Ελέγξτε τα κάτω πριν ζητήσετε επισκευή. (Ανατρέξτε στον πίνακα 7-3)

Πίνακας 7-3

Συμπτώματα	Αιτίες	Επίλυση
Δεν αλλάζει η ταχύτητα του ανεμιστήρα.	<ul style="list-style-type: none"> <li>• Ελέγξτε εάν στην οθόνη εμφανίζεται η ένδειξη AUTO.</li> </ul>	Όταν έχει επιλεγεί η λειτουργία AUTO, η μονάδα αλλάζει αυτόματα την ταχύτητα του ανεμιστήρα.
	<ul style="list-style-type: none"> <li>• Ελέγξτε εάν στην οθόνη εμφανίζεται η ένδειξη DRY.</li> </ul>	Όταν έχει επιλεγεί η λειτουργία DRY, η μονάδα αλλάζει αυτόματα την ταχύτητα του ανεμιστήρα. Η ταχύτητα του ανεμιστήρα μπορεί να αλλάξει κατά τις λειτουργίες COOL (ΨΥΞΗ), FAN ONLY (ΑΝΕΜΙΣΤΗΡΑΣ) και HEAT (ΘΕΡΜΑΝΣΗ).
Δεν μεταδίδεται εντολή από το ενσύρματο χειριστήριο ακόμα και εάν έχετε πιέσει το πλήκτρο ON/OFF.	<ul style="list-style-type: none"> <li>• Ελέγξτε αν το καλώδιο σήματος του ενσύρματου χειριστηρίου είναι τοποθετημένο στην σωστή επαφή στην εσωτερική μονάδα.</li> </ul>	Δεν υπάρχει σύνδεση με την παροχή ρεύματος.
Η ένδειξη της θερμοκρασίας δεν εμφανίζεται στην οθόνη.	<ul style="list-style-type: none"> <li>• Ελέγξτε εάν στην οθόνη εμφανίζεται η ένδειξη FAN ONLY.</li> </ul>	Κατά την λειτουργία ανεμιστήρα (FAN) δεν μπορεί να γίνει ρύθμιση θερμοκρασίας.
Οι ενδείξεις στην οθόνη εξαφανίζονται μετά από κάποιο χρονικό διάστημα.	<ul style="list-style-type: none"> <li>• Όταν πάρχει ένδειξη TIMER OFF, ελέγξτε αν έχει ολοκληρωθεί ο χρόνος λειτουργίας που έχει οριστεί.</li> </ul>	Η λειτουργία της κλιματιστικής μονάδας σταματάει την ώρα που έχει οριστεί.
Απενεργοποιείται η ένδειξη TIMER ON μετά από συγκεκριμένο χρονικό διάστημα	<ul style="list-style-type: none"> <li>• Όταν εμφανίζεται η ένδειξη TIMER ON στην οθόνη, ελέγξτε αν έχει αρχίσει η λειτουργία του χρονοδιακόπτη.</li> </ul>	Η κλιματιστική μονάδα κατά την ώρα που έχει επιλεγεί ενεργοποιείται αυτόματα η λειτουργία και η αντίστοιχη ένδειξη εξαφανίζεται από την οθόνη.
Δεν ακούγεται κανείς ήχος λήψης εντολής από την εσωτερική μονάδα ακόμα και αν πιέσετε το πλήκτρο ON/OFF.	<ul style="list-style-type: none"> <li>• Ελέγξτε αν το καλώδιο σήματος του ενσύρματου χειριστηρίου είναι τοποθετημένο στην σωστή επαφή στην εσωτερική μονάδα.</li> </ul>	Ελέγξτε το καλώδιο σήματος του ενσύρματου χειριστηρίου και έπειτα πιέστε συνεχόμενα 2 φορές το πλήκτρο ON/OFF

Ο σχεδιασμός και τα χαρακτηριστικά μπορεί να μεταβληθούν χωρίς προειδοποίηση για τη βελτίωση του προϊόντος. Συμβουλευτείτε τον προμηθευτή σας για λεπτομέρειες

# Ενεργοποιήστε την εγγύησή σας...

σε **5**  
απλά  
βήματα!



Σκανάρετε εδώ  
για τα έντυπα  
των εγγυήσεων

- 1** Συνδεθείτε στο site της Inventor στον ακόλουθο σύνδεσμο <http://www.inventoraircondition.gr/egiisi-inventor/>
- 2** Επιλέξτε τον τύπο του προϊόντος (κλιματιστικό ή συσκευή) για το οποίο θα ενεργοποιηθεί η εγγύηση
- 3** Επιλέξτε την εγγύηση που αντιστοιχεί στο προϊόν που έχετε στην κατοχή σας
- 4** Συμπληρώστε τα απαιτούμενα στοιχεία (κατόχου, εμπόρου και συσκευής) και πατήστε αποστολή
- 5** Θα λάβετε επιβεβαιωτικό μήνυμα στο e-mail σας για την ενεργοποίηση της εγγύησης

Για την υποβολή  
ηλεκτρονικών εγγυήσεων  
ηλεκτρολογήστε  
την παρακάτω διεύθυνση

**<https://www.inventoraircondition.gr/egiisi-inventor>**

## UNITATE INTERIOARĂ

## UNITATE EXTERIOARĂ

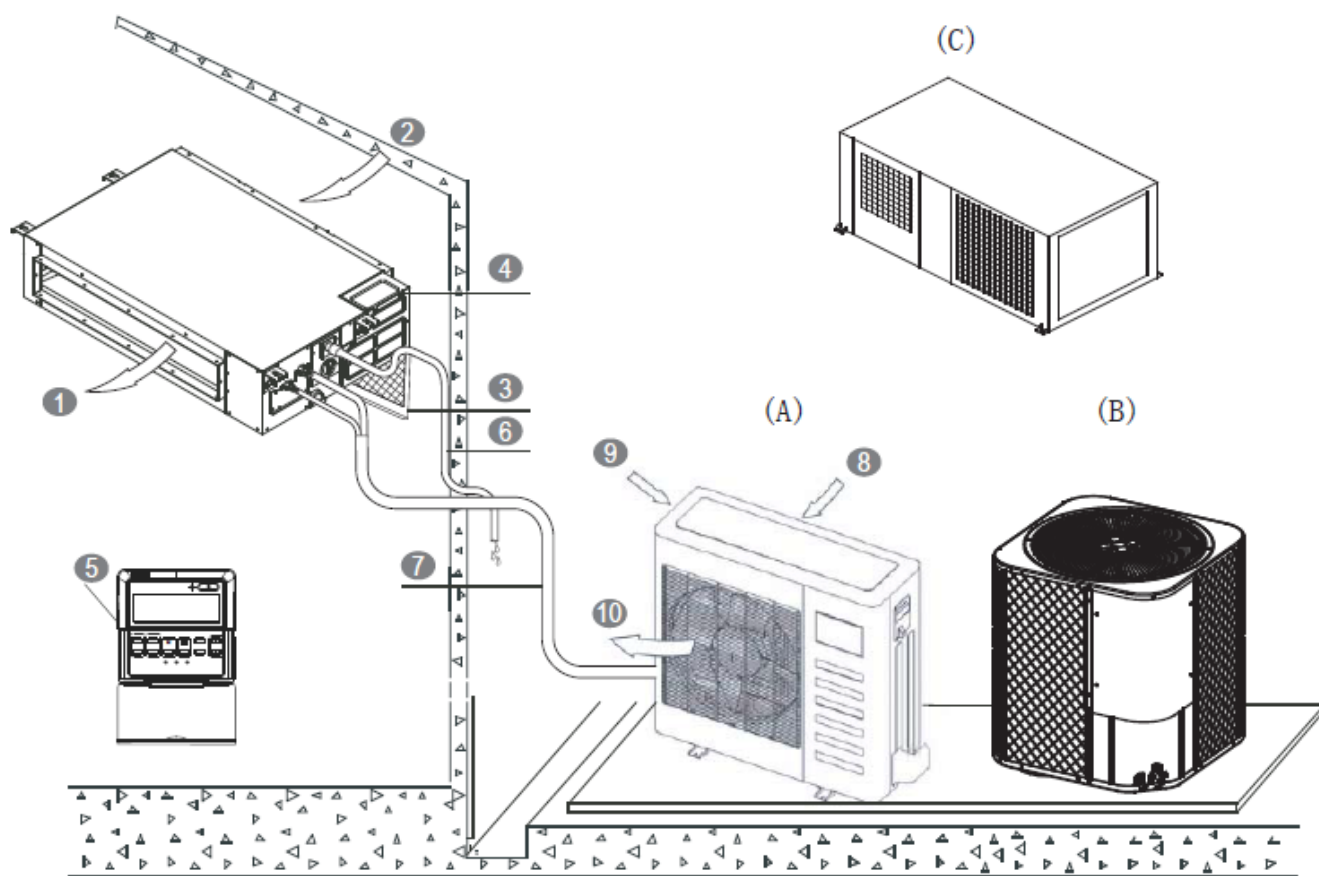

Fig.1

### UNITATEA INTERIOARĂ

### UNITATEA EXTERIOARĂ (A,B,C)

- 1 Evacuare aer
- 2 Admisie aer
- 3 Admisie aer (la unele modele)
- 4 Panoul de control electronic
- 5 Controlor cu fir (la unele modele)
- 6 Conductă de scurgere

- 7 Conductă de legătură
- 8 Admisie aer
- 9 Admisie aer (lateral și din spate)
- 10 Evacuare aer



### NOTĂ

Toate imaginile din acest manual au doar scop explicativ. Acestea pot fi ușor diferite de aparatul de aer condiționat achiziționat de dvs. (în funcție de model). Forma reală va fi cea luată în considerare.



INFORMAȚII IMPORTANTE PENTRU SIGURANȚĂ .....	2
DENUMIRE COMPONENTE .....	5
FUNCȚIONAREA ȘI PERFORMANȚA APARATULUI DE AER CONDIȚIONAT .....	6
SFATURI PENTRU O FUNCȚIONARE ECONOMICĂ .....	7
ÎNȚREȚINEREA .....	8
URMĂRIREA ERORILOR CARE NU SUNT DEFECȚIUNI ALE APARATULUI DE AER CONDIȚIONAT .....	11
DEPANAREA .....	12

## 1. INFORMAȚII IMPORTANTE PENTRU SIGURANȚĂ

Pentru a preveni vătămarea utilizatorului sau a altor persoane și daunele asupra proprietății, trebuie urmate următoarele instrucțiuni. Funcționarea incorectă datorată ignorării instrucțiunilor poate cauza vătămare sau daune.

Precauțiile pentru siguranță enumerate sunt împărțite în două categorii. În oricare dintre cazuri, există informații importante pentru siguranță care trebuie citite cu atenție.



### AVERTIZARE

-----  
Aparatul va fi instalat în conformitate cu reglementările naționale de cablare. Nerespectarea unei avertizări poate duce la deces.



### ATENȚIE

-----  
Nerespectarea unei atenționări poate duce la vătămare sau la avariarea echipamentului.



### AVERTIZARE

#### **Cereți vânzătorului dvs. instalarea aparatului de aer condiționat.**

Instalarea incompletă realizată de dvs. poate duce la scurgeri de apă, electrocutare și incendiu.

#### **Cereți vânzătorului dvs. ajutorul pentru îmbunătățirea, reparația și întreținerea aparatului.**

Îmbunătățirile, reparațiile și întreținerea incompletă pot duce la scurgeri de apă, electrocutare și incendiu.

**Pentru a evita electrocutarea, incendiul sau vătămarea, sau la observarea oricărei anomalii cum ar fi mirosul de fum, opriți alimentarea cu electricitate și sunați vânzătorul pentru instrucțiuni.**

#### **Nu permiteți niciodată ca unitatea interioară sau telecomanda să se ude.**

Acest lucru poate duce la electrocutare sau incendiu.

#### **Nu apăsați niciodată butoanele telecomenzii cu obiecte tari sau ascuțite.**

Telecomanda poate fi avariată.

**Nu înlocuiți niciodată siguranța cu una cu voltaj nominal greșit sau alte cabluri atunci când se arde o siguranță.**

Utilizarea unui cablu sau a unui cablu din cupru poate duce la avarierea aparatului sau poate cauza un incendiu.

**Nu este sănătos pentru dvs. să vă expuneți corpul la fluxul de aer pentru timp îndelungat.**

**Nu introduceți degetele, bețe sau alte obiecte în admisia sau evacuarea de aer.**

Atunci când ventilatorul se învâрте la viteze mari, acest lucru poate cauza vătămare.

**Nu utilizați niciodată un spray inflamabil, de genul unui fixativ de păr, lac sau vopsea în apropierea aparatului.**

Acest lucru poate duce la incendiu.

**Nu atingeți niciodată evacuarea de aer sau lamelele orizontale în timp ce oscilația flapsului este funcțională.**

Vă puteți prinde degetele sau aparatul se poate defecta.

**Nu introduceți niciodată obiecte în admisia sau evacuarea de aer.**

Obiectele ce ating ventilatorul la viteze mari pot fi periculoase.

**Nu inspectați sau nu reparați singur(ă) aparatul.**

Cereți unei persoane calificate de la service să realizeze aceste lucrări.

**Nu aruncați acest produs ca și deșeu menajer nesortat. Colectarea acestui deșeu se face separat deoarece este necesar un tratament special.**

Nu aruncați acest produs ca și deșeu menajer nesortat, utilizați centre de sortare specializate.

Contactați administrația dvs. locală pentru informații cu privire la disponibilitatea sistemelor de colectare disponibile.

**Dacă aparatele electrice sunt aruncate în gropile de gunoi sau deșeuri, substanțe periculoase se pot infiltra în pânza freatică și pot pătrunde în lanțul alimentar, dăunând sănătății și bunăstării dvs.**

**Pentru a preveni scurgerea agentului frigorific, contactați vânzătorul dvs.**

Atunci când sistemul este instalat și funcționează într-o cameră mică, este necesară păstrarea concentrației agentului frigorific sub limită în cazul în care există șansa ca acesta să se scurgă. În caz contrar, oxigenul din cameră poate scădea, ducând la accidente serioase.

**Agentul frigorific din aparatul de aer condiționat este sigur și în mod normal nu curge.**

Dacă agentul frigorific curge în cameră, contactul cu un foc de arzător, un radiator sau un aragaz poate duce la formarea de gaze nocive.

**Opriți orice dispozitive de încălzire cu aprindere, aerisiți camera și contactați vânzătorul de la care ați achiziționat aparatul.**

Nu utilizați aparatul de aer condiționat până ce o persoană de la service nu vă confirmă că zona în care agentul frigorific curgea a fost reparată.



---

## ATENȚIE

---

**Nu utilizați aparatul de aer condiționat în alte scopuri.**

Pentru a evita orice deteriorare a calității, nu utilizați aparatul pentru a răci instrumente de precizie, alimente, plante, animale sau lucrări de artă.

**Înainte de curățare, asigurați-vă că opriți funcționarea, opriți comutatorul sau trageți aparatul din priză.**

În caz contrar, se poate ajunge la electrocutare sau vătămare.

**Pentru a evita electrocutarea sau incendiul, asigurați-vă că instalați un detector de scurgeri electrice la împământare.**

**Asigurați-vă că aparatul de aer condiționat este împământat.**

Pentru a evita electrocutarea, asigurați-vă că aparatul este legat la împământare și că firul pentru împământare nu este legat la o conductă de gaze sau de apă, de un paratrăsnet sau un fir de telefon.

**Pentru a preveni vătămarea, nu înlăturați grilajul de protecție al ventilatorului unității exterioare.**

**Nu manevrați aparatul de aer condiționat cu mâinile ude.**

Poate apărea electrocutarea.

**Nu atingeți lamelele schimbătorului de căldură.**

Aceste lamele sunt ascuțite și pot duce la vătămare prin tăiere.

**Nu puneți obiecte ce pot fi avariate de umezeală sub unitatea interioară.**

Poate apărea condensul dacă umiditatea este de peste 80%, atunci evacuarea de scurgere este blocată și filtrul este poluat.

**După utilizare un timp îndelungat, verificați suportul și montajul aparatului pentru defecțiuni.**

Dacă sunt avariate, aparatul poate cădea și poate apărea vătămarea.

**Pentru a evita lipsa de oxigen, aerisiți bine camera dacă utilizați un radiator cu arzător împreună cu aparatul de aer condiționat.**

**Aranjați furtunul de evacuare pentru a asigura o scurgere lină.**

Scurgerea incompletă poate duce la udarea imobilului, mobilei, etc.

**Nu atingeți niciodată componentele interne ale controlerului.**

Nu îndepărtați panoul frontal. Unele componente din interior sunt periculoase la atingere și poate apărea avariarea aparatului.

**Nu expuneți niciodată copiii mici, plantele sau animalele direct la fluxul de aer.**

Pot să apară efecte adverse asupra copiilor mici, animalelor și plantelor.

**Nu permiteți unui copil să urce pe unitatea exterioară și evitați amplasarea de obiecte pe aceasta.**

Căderea sau rostogolirea poate duce la vătămare.

**Nu puneți în funcțiune aparatul de aer condiționat atunci când utilizați un insecticid ce implică fumegarea camerei.**

Nerespectarea acestei măsuri poate duce la depozitarea chimicalelor în aparat, lucru care poate pune în pericol sănătatea celor hipersensibili la chimicale.

**Nu amplasați aparate care produc flacără deschisă expuse la fluxul de aer al unității sau sub unitatea interioară.**

Poate duce la aprinderea incompletă sau deformarea unității datorită căldurii.

**Nu instalați aparatul de aer condiționat în nicio locație în care se pot scurge gaze inflamabile.**

Dacă gazele se scurg și persistă în jurul aparatului de aer condiționat, poate izbucni un incendiu.

**Aparatul nu este destinat utilizării de către copiii mici sau persoanele cu dizabilități fără supraveghere.**

Nu puneți aparatul de aer condiționat în funcțiune într-o cameră cu umiditate mare de genul unei băi sau spălătorii.

Acest aparat poate fi folosit de către copiii cu vârsta de peste 8 ani și de către persoanele cu capacități fizice și mentale reduse sau cu lipsă de experiență sau cunoștințe dacă sunt supravegheați sau li se acordă instruire cu privire la folosirea aparatului în siguranță și dacă înțeleg pericolele pe care le implică. Copiii nu trebuie să se joace cu aparatul. Mentenanța uzuală și curățarea nu se vor face de către copii fără supraveghere.

Acest aparat nu este destinat utilizării de către persoane (inclusiv copii) cu capacități fizice reduse, senzoriale sau mentale, sau lipsite de experiență și cunoștințe, cu excepția cazului în care acestea au fost supravegheate și instruite cu privire la utilizarea aparatului de către o persoană responsabilă pentru siguranța lor.

Copiii trebuie supravegheați pentru a vă asigura că nu se joacă cu aparatul.

În cazul în care cablul de alimentare este deteriorat, acesta trebuie înlocuit de către producător, agentul de service sau persoane calificate, în scopul de a evita un pericol.

---

## 2. DENUMIREA COMPONENTELOR

Aparatul de aer condiționat este compus din unitatea interioară, unitatea exterioară, conducta de legătură și telecomanda.

(Consultați Fig.2-1)

Indicatori de funcționare pe panoul de afișaj al unității interioare

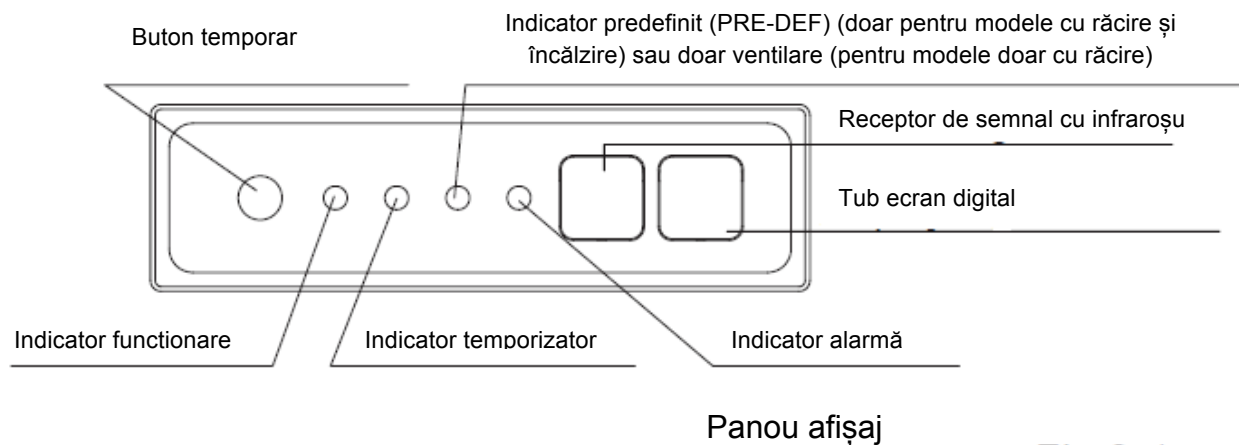

Fig.2-1

Pentru tipul cu invertor, acest comutator este utilizat pentru servicii post-vânzare, în scopuri de service, utilizatorul nu trebuie să îl utilizeze.

Pentru tipurile cu frecvență fixă, această funcție este utilizată pentru a opera temporar aparatul în cazul în care rătăciți telecomanda sau în cazul în care se termină bateriile. Pot fi selectate două module ce includ AUTOMAT FORȚAT (FORCED AUTO) și RĂCIRE FORȚATĂ (FORCED COOL) prin BUTONUL

TEMPORAR de pe caseta de control a grilajului de admisie aer a unității interioare. Odată ce apăsați acest buton, aparatul de aer condiționat va funcționa în următoarea ordine: AUTOMAT FORȚAT (FORCED AUTO), RĂCIRE FORȚATĂ (FORCED COOL), OPRIRE (OFF) și înapoi la AUTOMAT FORȚAT (FORCED AUTO).

#### 1. AUTOMAT FORȚAT (FORCED AUTO)

Indicatorul de FUNCȚIONARE este aprins iar aparatul de aer condiționat se va întoarce la modulul AUTOMAT FORȚAT (FORCED AUTO). Funcționarea prin telecomandă poate fi activă conform cu semnalul primit.

#### 2. RĂCIRE FORȚATĂ (FORCED COOL)

Indicatorul de FUNCȚIONARE se aprinde intermitent, aparatul de aer condiționat se va întoarce la modulul AUTOMAT FORȚAT (FORCED AUTO) după ce este forțat să răcească cu viteza de ventilare setată pe RIDICAT timp de 30 minute. Funcționarea prin telecomandă este dezactivată.

#### 3. OPRIRE (OFF)

Indicatorul de FUNCȚIONARE se stinge. Aparatul de aer condiționat este OPRIT (OFF) în timp ce funcționarea prin telecomandă este permisă.



### NOTĂ

Acest manual nu include funcționarea telecomenzii, vă rugăm consultați <<Manualul de Utilizare pentru Telecomandă>> ce vine împreună cu pachetul aparatului pentru detalii.

## 3. FUNCȚIONAREA ȘI PERFORMANȚA APARATULUI DE AER CONDIȚIONAT

Utilizați sistemul la următoarele temperaturi pentru o funcționare sigură și eficientă. Temperatura maximă de funcționare pentru aparatul de aer condiționat (Răcire/ Încălzire).

Tabelul 2-1

Modul	Temperatură	Temperatură exterioară	Temperatură interioară
Funcționarea în modulul RĂCIRE (COOL)		18°C~43°C /64°F~109°F	17°C~32°C (62°F~90°F)
		-7°C~43°C / 20°F~109°F (pentru modele cu sisteme de răcire cu temperaturi joase)	
		18°C~52°C /64°F~126°F (pentru modelele tropicale speciale)	
Funcționarea în modulul ÎNCĂLZIRE (HEAT) (cu excepția modelelor doar cu răcire)		-7°C~24°C /20°F~76°F	0°C~30°C / 32°F~86°F
Funcționarea în modulul DEZUMIDIFICARE (DRY)		18°C~43°C /64°F~109°F	17°C~32°C (62°F~90°F)
		18°C~52°C /64°F~126°F (pentru modelele tropicale speciale)	

**Tabelul 2-2 (pentru aparatele de aer condiționat de tip invertor)**

Modul	Temperatură	Temperatură exterioară	Temperatură interioară
Funcționarea în modulul RĂCIRE (COOL)		0°C~50°C / 32°F~122°F	17°C~32°C (62°F~90°F)
		-15°C~50°C / 5°F~122°F (pentru modele cu sisteme de răcire cu temperaturi joase)	
Funcționarea în modulul ÎNCĂLZIRE (HEAT) (cu excepția modelelor doar cu răcire)		-15°C~24°C / 5°F~76°F	0°C~30°C / 32°F~86°F
Funcționarea în modulul DEZUMIDIFICARE (DRY)		0°C~50°C / 32°F~122°F	17°C~32°C (62°F~90°F)

**NOTĂ**

1. Dacă aparatul de aer condiționat este utilizat în afara condițiilor de mai sus, acest lucru poate duce la funcționarea anormală a aparatului.
2. Este normal fenomenul privind condensul de pe suprafața aparatului de aer condiționat atunci când există umiditate relativă mai mare în cameră. Vă rugăm închideți ușa și ferestrele.
3. Performanța optimă va fi atinsă în aceste intervale de temperatură pentru funcționare.

**Funcția de protecție de trei minute**

O funcție de protecție previne aparatul de aer condiționat să repornească pentru aproximativ 3 minute atunci când repornește imediat după funcționare.

**În cazul căderilor de electricitate**

Penele de curent în timpul funcționării vor opri complet aparatul.

- Indicatorul de funcționare de pe unitatea interioară va începe să se aprindă intermitent atunci când revine alimentarea cu electricitate.
- Pentru a reporni funcționarea, apăsați butonul PORNIRE/ OPRIRE (ON/OFF) de pe telecomandă.
- Trăsnetul sau un telefon fără fir de la o mașină aflate în apropiere pot produce defectarea aparatului.

**4. SFATURI PENTRU O FUNCȚIONARE ECONOMICĂ**

Trebuie respectate următoarele pentru a asigura o funcționare economică. (Consultați capitolul aferent pentru detalii)

- Ajustați adecvat direcția fluxului de aer pentru a evita ca acesta să bată direct către dvs.
- Ajustați adecvat temperatura din cameră pentru un mediu confortabil și pentru a evita răcirea sau încălzirea în exces.
- În timpul operațiunii de răcire închideți draperiile pentru a evita lumina directă a soarelui.
- Pentru a păstra fluxul de aer rece sau cald în cameră, nu deschideți niciodată ușile sau ferestrele mai des decât este nevoie.

- Setati temporizatorul pentru timpul dorit de functionare.
- Nu amplasati obiecte in apropierea admisiei de aer si evacuării de aer ale aparatului. Acest lucru poate cauza scaderea efectului sau oprirea bruscă a funcționării.
- Ajustati adecvat direcția fluxului de aer pentru a evita ca acesta să bată direct către dvs.
- Ajustati adecvat temperatura din cameră pentru un mediu confortabil și pentru a evita răcirea sau încălzirea în exces.
- În timpul operațiunii de răcire închideți draperiile pentru a evita lumina directă a soarelui.
- Pentru a păstra fluxul de aer rece sau cald în cameră, nu deschideți niciodată ușile sau ferestrele mai des decât este nevoie.
- Dacă planificați să nu utilizați un timp îndelungat aparatul, vă rugăm scoateți bateriile din telecomandă. Atunci când este pornit, va fi consumată ceva energie electrică, chiar dacă aparatul de aer condiționat nu este în funcțiune. Astfel, vă rugăm scoateți din priză pentru a economisi electricitate. Și vă rugăm să porniți alimentarea electrică cu 12 ore înainte de repornirea aparatului pentru a asigura o funcționare fără probleme.
- Un filtru de aer înfundat va reduce eficiența de răcire sau încălzire, așa că vă rugăm să îl curățați o dată la două săptămâni.

## 5. ÎNTREȚINEREA



### ATENȚIE

**Înainte de a curăța aparatul de aer condiționat asigurați-vă că alimentarea cu energie electrică este oprită.**

**Verificați dacă firele nu sunt rupte sau deconectate.**

**Utilizați o cârpă uscată pentru a șterge unitatea interioară și telecomanda.**

**Utilizați o cârpă umedă pentru unitatea interioară doar dacă aparatul este foarte murdar.**

**Nu utilizați niciodată o cârpă umedă pentru telecomandă.**

Nu utilizați o cârpă de praf tratată chimic pentru ștergere sau nu lăsați un astfel de material pe aparat perioade lungi de timp.

Poate dăuna sau decolora suprafața aparatului.

Nu utilizați benzină, diluant, praf de curățat sau solvenți similari pentru curățare.

Aceștia pot cauza crăpături sau deformarea suprafeței de plastic.

- **Întreținerea după o perioadă lungă de neutilizare**  
(de ex. la începutul sezonului)

Verificați și îndepărtați orice poate bloca ventilarea de admisie sau evacuare ale unității interioare și unității exterioare.

Curățați filtrele de aer și capacele unității interioare.

Consultați secțiunea „Curățarea filtrului de aer” pentru detalii cu privire la modul de acționare și asigurare a instalării filtrelor de aer curate înapoi în poziția lor.

Porniți curentul cu cel puțin 12 ore înainte de funcționarea aparatului pentru a asigura o funcționare ușoară. De îndată ce aparatul este pornit, apare ecranul de afișaj al telecomenzii.

## ■ **Întreținerea înainte de o perioadă lungă de neutilizare**

(de ex. la sfârșitul sezonului)

Lăsați unitatea interioară să funcționeze doar în modulul ventilare pentru aproximativ o jumătate de zi pentru a usca partea interioară a aparatului.

Curățați filtrele de aer și capacele unității interioare. Consultați secțiunea „Curățarea filtrului de aer” pentru detalii cu privire la modul de acționare și asigurare a instalării filtrelor de aer curate înapoi în poziția lor.

## ■ **Curățarea filtrului de aer (la unele modele)**

Filtrul de aer poate preveni ca praful și alte particule să pătrundă la interior. În cazul blocării filtrului, eficiența de funcționare a aparatului de aer condiționat poate să scadă mult.

Astfel, filtrul trebuie curățat o dată la două săptămâni pe timpul perioadelor lungi de utilizare.

Dacă aparatul de aer condiționat este instalat într-un loc cu mult praf, curățați frecvent filtrul de aer.

Dacă praful acumulat este prea dens pentru a fi curățat, înlocuiți filtrul de aer cu unul nou (filtrele de aer ce pot fi înlocuite reprezintă o funcție opțională).

Curățarea filtrului trebuie realizată de către un furnizor adecvat de servicii.

- Deoarece aparatul achiziționat de dvs. este o unitate cu ventilare în partea din spate, vă rugăm îndepărtați filtrul fixat cu șuruburi (2 șuruburi) și dați jos filtrul trăgând în direcția opusă aparatului.

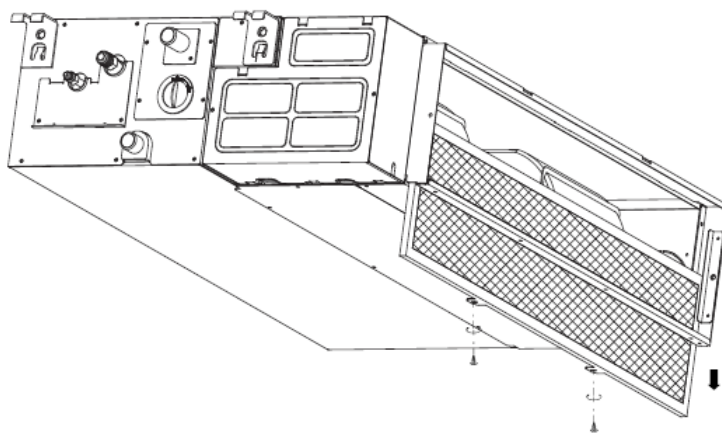

Fig.5-1

- Deoarece achiziționat

aparatur  
de dvs.



este o unitate cu ventilare descendentă, vă rugăm împingeți ușor filtrul în sus pentru a permite clemelor de poziționare să se desprindă de orificiile de fixare a bordurii, și scoateți filtrul conform direcției săgeții din figura ce urmează.

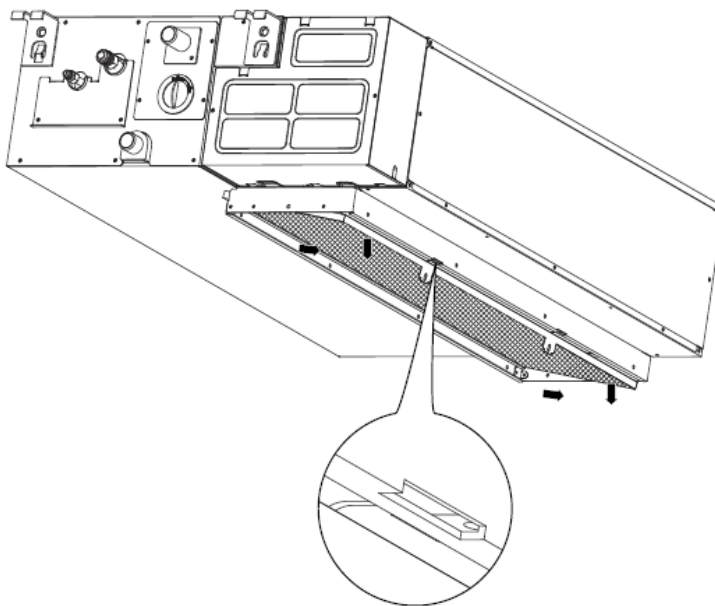

Fig.5-2

- Curățați filtrul de aer (se poate folosi aspiratorul sau apă curată pentru a curăța filtrul de aer. Dacă acumularea de praf este prea densă, vă rugăm folosiți o perie moale și detergent fin pentru a-l curăța și uscați-l la loc răcoros).

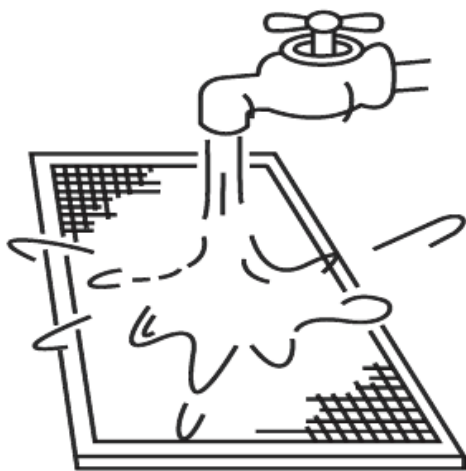

Fig.5-3

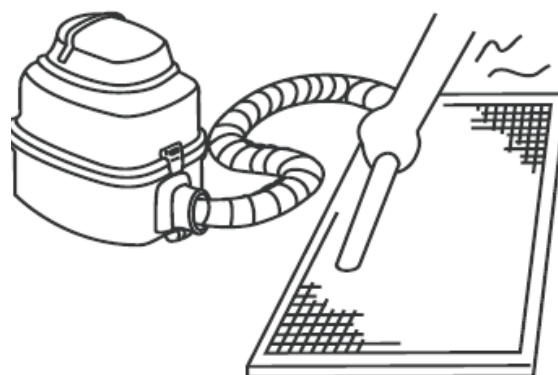

Fig.5-4

Partea de admisie aer trebuie să fie cu fața în sus la utilizarea aspiratorului. (Consultați Fig. 5-4).  
Partea de admisie aer trebuie să fie cu fața în jos la utilizarea apei. (Consultați Fig. 5-3).



---

## ATENȚIE

---

**Nu uscați filtrul de aer în lumina directă a soarelui sau lângă foc.**

---

Reinstalați filtrul de aer.

Instalați și închideți grilajul admisiei de aer în ordinea inversă a etapelor 1 și 2 și conectați cablurile cutiei de control la terminalele corespunzătoare de pe corpul principal al aparatului.

## 6. URMĂRIREA ERORILOR CARE NU SUNT DEFECȚIUNI ALE APARATULUI DE AER CONDIȚIONAT

### Eroarea 1: Sistemul nu funcționează

- Aparatul de aer condiționat nu pornește imediat după ce este apăsat butonul PORNIRE / OPRIRE (ON/OFF) de pe telecomandă.

Dacă indicatorul de funcționare se aprinde, sistemul se află într-o situație normală. Pentru a preveni supraîncălzirea motorului compresorului, aparatul de aer condiționat începe la 3 minute după ce este pornit (ON).

- Dacă indicatorul de funcționare și indicatorul predefinit „PRE-DEF” (la modelele cu răcire și încălzire) sau dacă indicatorul doar ventilare (la modelul doar cu răcire) se aprinde, aceasta înseamnă că ați ales modelul cu încălzire. La începutul funcționării, compresorul nu pornește, apare protecția „anti-aer rece” a unității interioare din cauza temperaturii scăzute a fluxului evacuat de aer.

### Eroarea 2: Schimbarea în modulul ventilare în timpul modulului răcire

- Pentru a preveni înghețarea dispozitivului de evaporare interior, sistemul se va schimba în modulul ventilare automat și va reveni la modulul răcire după scurt timp.
- Atunci când scade temperatura camerei până la temperatura setată, compresorul se stinge și unitatea interioară se schimbă pe modulul ventilare; atunci când temperatura crește, compresorul pornește din nou. Același lucru se întâmplă în modulul încălzire.

### Eroarea 3: O ceață albă iese din aparat

#### Eroarea 3.1: Unitatea interioară

- Atunci când umiditatea este mare în timpul operațiunii de răcire și dacă interiorul unității interioare este foarte contaminat, distribuția temperaturii în interiorul camerei devine inegală. Este necesară curățarea interiorului unității interioare. Cereți vânzătorului dvs. mai multe detalii cu privire la curățarea unității. Această operațiune necesită o persoană calificată de la service.

#### Eroarea 3.2: Unitatea interioară, unitatea exterioară

- Atunci când sistemul se schimbă pe operațiunea de încălzire după operațiunea de degivrare, umezeala rezultată din degivrare se transformă în abur și este eliminat.

## **Eroarea 4: Zgomote în timpul răcirii aparatului de aer condiționat**

### **Eroarea 4.1: Unitatea interioară**

- Un sunet continuu de „răzuire” se aude atunci când sistemul se află în funcționarea pe răcire sau când se oprește.  
Atunci când pompa de scurgere (accesoriu opțional) este în funcțiune, se aude acest zgomot.
- Un sunet de scârțâit de genul „puf-puf” se aude atunci când sistemul se oprește după funcționarea în încălzire.  
Zgomotele sunt provocate de expansiunea și contractarea părților de plastic rezultate în urma schimbării de temperatură.

### **Eroarea 4.2: Unitatea interioară, unitatea exterioară**

- Un zgomot continuu se șuierat se aude atunci când sistemul este în funcțiune.  
Acesta este zgomotul agentului frigorific care curge atât prin unitatea interioară cât și prin unitatea exterioară.
- Un sunet de șuierat se aude la începerea sau imediat după oprirea funcționării sau a operațiunii de degivrare.  
Acesta este sunetul agentului frigorific și este cauzat de oprirea curgerii sau schimbarea sensului de scurgere.

### **Eroarea 4.3: Unitatea exterioară**

- Atunci când se schimbă tonul zgomotului de funcționare.  
Zgomotul este cauzat de schimbarea frecvenței.

## **Eroarea 5: Iese praf din aparat**

- Atunci când aparatul este utilizat pentru prima oară după un timp îndelungat.  
Aceasta se întâmplă deoarece praful a pătruns în unitate.

## **Eroarea 6: Aparatul poate emana mirosuri**

- Aparatul poate să absoarbă mirosul camerei, mobilei, de țigări, etc. și apoi să îl emane.

## **Eroarea 7: Ventilatorul unității exterioare nu se învârte**

- În timpul funcționării. Viteza ventilatorului este controlată pentru a optimiza funcționarea aparatului.

# **7. DEPANAREA**

## **8.1 Defecțiuni și cauze ale aparatului de aer condiționat**

**Dacă una din următoarele defecțiuni are loc, opriți funcționarea, opriți alimentarea cu electricitate și contactați vânzătorul dvs. local.**

- Indicatorul de funcționare se aprinde intermitent și rapid (5Hz). Acest indicator încă se aprinde intermitent rapid după oprirea funcționării și repornirea aparatului (Consultați tabelul 7-2).
- Telecomanda nu primește semnal sau butoanele nu funcționează bine.
- Un dispozitiv de siguranță de genul unei siguranțe sau a unui întrerupător este declanșat

frecvent.

- Obiecte sau apă pătrund în aparat.
- Se scurge apă din unitatea interioară.
- Alte defecțiuni.

**Dacă sistemul nu funcționează adecvat cu excepția cauzelor de mai sus sau defecțiunile de mai sus sunt evidente, analizați sistemul conform cu următoarele proceduri. (Consultați tabelul 7-3).**



## ATENȚIE

**Vă rugăm opriți alimentarea electrică atunci când defecțiunile menționate mai sus apar, verificați dacă voltajul utilizat este în afara intervalului nominal, verificați dacă instalarea aparatului de aer condiționat este corectă, apoi introduceți din nou în priză după 3 minute de oprire. Dacă problema persistă încă, vă rugăm contactați locația de service locală sau producătorul echipamentului.**

Tabelul 7-1a



Nr.	DEFINIȚIE DEFECTIUNE ȘI PROTECȚIE	LED 1 FUNCTIO- NARE	LED 2 TEMPO- RIZATOR	LED 3 VENTILARE	LED 4 ALARMĂ	AFIȘAJ TUB DIGITAL
1	Scăpare de sub control viteză de ventilare a unității interioare			⊙	⊙	E8
2	Canalul de verificare al unității exterioare intern CO MM este anormal		⊙			E1
3	Canalul de verificare al senzorului de temperatură ambientală este anormal	⊙				E2
4	Canalul de verificare al senzorului de temperatură conductă este anormal (T2)	⊙				E3
5	Canalul de verificare al senzorului de temperatură conductă este anormal (T2B)	⊙				E4
6	Defecțiune EPPROM			⊙		E7
7	Defecțiune alarmă nivel apă				⊙	EE
8	Defecțiune a unității exterioare				⊙	Ed
9	Defecțiune comunicare între două unități interioare		⊙		⊙	F3
10	Alte defecțiuni ale modelelor cu două unități interioare	⊙			⊙	F4

● Indicator luminos      ⊙ Aprindere intermitentă la 2,5Hz      ○ Aprindere intermitentă la 0,5Hz

**Aplicabil doar aparatului de aer condiționat cu inverter**

**Tabelul 7-1b**

...	DEFINIȚIE DEFECTIUNE ȘI PROTECȚIE	LED 1 FUNCTIO- NARE	LED 2 TEMPO- RIZATOR	LED 3 VENTILARE	LED 4 ALARMĂ	AFIȘAJ TUB DIGITAL
.	Canalul de verificare al senzorului de temperatură ambientală este anormal		⊙			E2
.	Canalul de verificare al senzorului de temperatură conductă este anormal	⊙				E3
.	Canalul de verificare al senzorului extern de temperatură este anormal			⊙		E4
.	Defecțiune a unității exterioare	⊙	⊙	⊙	⊙	E6
.	Defecțiune senzor temperatură pompă				⊙	E5
.	Defecțiune EEPROM	⊙	⊙			E7
.	Defecțiune alarmă nivel apă				⊙	E8
.	Scăpare de sub control viteză motor de tip DC		⊙		⊙	Eb
.	Defecțiune presiune joasă a unității exterioare	⊙	⊙	⊙		Ed

 Indicator luminos     
  Aprindere intermitentă la 2,5Hz     
  Aprindere intermitentă la 0,5Hz

**Aplicabil doar aparatului de aer condiționat cu frecvență fixă**

**Tabelul 7-2**

Erori	Cauze	Soluție
<b>Aparatul nu pornește</b>	<ul style="list-style-type: none"> <li>• Pană de curent.</li> <li>• Comutatorul electric este oprit.</li> <li>• Siguranța sau comutatorul pot fi arse.</li> <li>• Bateriile telecomenzii sunt terminate sau există altă problemă cu controlorul.</li> </ul>	<ul style="list-style-type: none"> <li>• Așteptați revenirea curentului.</li> <li>• Porniți comutatorul.</li> <li>• Înlocuiți siguranța.</li> <li>• Înlocuiți bateriile sau verificați controlorul.</li> </ul>
<b>Fluxul de aer este normal dar răcirea nu este completă</b>	<ul style="list-style-type: none"> <li>• Temperatura nu este setată corect.</li> <li>• Este posibil să fie în timpul celor 3 minute de protecție a compresorului.</li> </ul>	<ul style="list-style-type: none"> <li>• Setati corect temperatura.</li> <li>• Așteptați.</li> </ul>
<b>Aparatul pornește și se oprește des</b>	<ul style="list-style-type: none"> <li>• Agentul frigorific este prea mult sau prea puțin.</li> <li>• Nu mai este aer sau gaz de întărire în circuitul de agent frigorific.</li> <li>• Compresorul este defect.</li> <li>• Voltajul este prea ridicat sau prea scăzut.</li> <li>• Circuitul sistemului este blocat.</li> </ul>	<ul style="list-style-type: none"> <li>• Verificați scurgerile și reîncărcați adecvat agentul frigorific.</li> <li>• Aspirați și încărcați agentul frigorific.</li> <li>• Realizați mentenanța sau schimbați compresorul.</li> <li>• Instalați manostatul</li> <li>• Găsiți motive și soluții.</li> </ul>
<b>Efect scăzut de răcire</b>	<ul style="list-style-type: none"> <li>• Schimbătorul de căldură al unității interioare și unității exterioare este murdar.</li> <li>• Filtrul de aer este murdar.</li> <li>• Admisia / evacuarea unității interioare / unității exterioare sunt blocate.</li> <li>• Ușile și ferestrele sunt deschise.</li> <li>• Lumina soarelui bate direct.</li> <li>• Prea multe surse de căldură.</li> <li>• Temperatura exterioară este prea</li> </ul>	<ul style="list-style-type: none"> <li>• Curățați schimbătorul de căldură.</li> <li>• Curățați filtrul de aer.</li> <li>• Eliminați toate impuritățile și fluidizați fluxul de aer.</li> <li>• Închideți ușile și ferestrele.</li> <li>• Instalați draperii pentru a vă proteja de lumina solară.</li> <li>• Reduceți sursele de căldură.</li> <li>• Verificați scurgerile și</li> </ul>

	<p>mare.</p> <ul style="list-style-type: none"> <li>• Scurgerea agentului frigorific sau lipsa agentului frigorific.</li> </ul>	reîncărcați adecvat agentul frigorific.
<b>Efect scăzut de încălzire</b>	<ul style="list-style-type: none"> <li>• Temperatura externă este mai mică de 7°C.</li> <li>• Ușile și ferestrele nu sunt închise complet.</li> <li>• Scurgerea agentului frigorific sau lipsa agentului frigorific.</li> </ul>	<ul style="list-style-type: none"> <li>• Utilizați un dispozitiv de încălzire.</li> <li>• Închideți ușile și ferestrele.</li> <li>• Verificați scurgerile și reîncărcați adecvat agentul frigorific.</li> </ul>

## 7.2 Defecțiuni și cauze defecțiuni ale controlorului cu fir

Înainte de a cere operațiunile de service sau reparații, verificați următoarele puncte. (Consultați tabelul 7-3).

**Tabelul 7-3**

<b>Erori</b>	<b>Cauze</b>	<b>Soluție</b>
<b>Viteza de ventilare nu poate fi schimbată.</b>	<ul style="list-style-type: none"> <li>• Verificați dacă modulul indicat pe ecran este „AUTOMAT (AUTO)”</li> </ul>	Atunci când modulul automat este selectat, aparatul de aer condiționat va schimba automat viteza de ventilare.
	<ul style="list-style-type: none"> <li>• Verificați dacă modulul indicat pe ecran este „DEZUMIDIFICARE (DRY)”</li> </ul>	Atunci când se alege operațiunea de dezumidificare, aparatul de aer condiționat schimbă automat viteza de ventilare. Viteza de ventilare poate fi aleasă în timpul modulelor „RĂCIRE (COOL)”, „DOAR VENTILARE (FAN ONLY)” și „ÎNCĂLZIRE (HEAT)”.
<b>Semnalul telecomenzii nu este transmis chiar și atunci când butonul PORNIT/ OPRIT (ON/OFF) este apăsat.</b>	<ul style="list-style-type: none"> <li>• Verificați dacă bateriile din telecomandă sunt descărcate.</li> </ul>	Alimentarea cu electricitate este oprită.
<b>Indicatorul de TEMPERATURĂ (TEMP) nu se aprinde</b>	<ul style="list-style-type: none"> <li>• Verificați dacă modulul indicat pe ecran este DOAR VENTILARE (FAN ONLY)</li> </ul>	Temperatura nu poate fi setată în timpul modulului VENTILARE (FAN).
<b>Indicatoarele de pe ecran dispar după scurgerea timpului</b>	<ul style="list-style-type: none"> <li>• Verificați dacă funcționarea temporizatorului a ajuns la final atunci când este indicat pe ecran TEMPORIZATOR OPRIT (TIMER OFF).</li> </ul>	Funcționarea aparatului de aer condiționat se va opri la timpul setat.
<b>Indicatorul TEMPORIZATOR PORNIT (TIMER ON) se stinge după scurgerea unui anumit interval de timp.</b>	<ul style="list-style-type: none"> <li>• Verificați dacă funcționarea temporizatorului a început atunci când este indicat pe ecran TEMPORIZATOR PORNIT (TIMER ON).</li> </ul>	Până la timpul setat, aparatul de aer condiționat va începe automat iar indicatorul aferent se va stinge.
<b>Nu se aude niciun semnal de primire de la unitatea interioară chiar și atunci când este apăsat butonul PORNIRE / OPRIRE (ON/OFF).</b>	<ul style="list-style-type: none"> <li>• Verificați dacă semnalul de transmitere al telecomenzii este îndreptat adecvat către receptorul de semnal cu infraroșu de pe unitatea interioară atunci când se apasă butonul PORNIRE/ OPRIRE (ON/OFF).</li> </ul>	Îndreptați direct emițătorul de semnal al telecomenzii către receptorul de semnal de pe unitatea interioară, iar apoi apăsați butonul PORNIRE/ OPRIRE (ON/OFF) de două ori.

# Activati-va garantia...

in **5**  
Pasi  
**simpli!**



Scanati codul QR pentru  
a obtine formularul de garantie.

**1** Accesati link-ul de mai jos:  
<https://www.inventoraerconditionat.ro/certificatul-de-garantie-inventor-aer-conditionat-si-electrocasnice>

**2** Alegeti tipul de produs pentru care vreti sa activati garantia (aparat de aer conditionat, alt aparat electrocasnic).

**3** Alegeti tipul de garantie corespunzator produsului achizitionat.

**4** Completati formularul cu informatiile cerute (numele proprietarului, magazinul, produsul) si apasati SEND.

**5** Veti primi care va confirma activarea garantiei.

Pentru inregistrarea  
electronicaa garantiei, va rugam sa  
accesati link-ul de mai jos :

<https://www.inventoraerconditionat.ro/certificatul-de-garantie-inventor-aer-conditionat-si-electrocasnice>



# AIR CONDITIONING SYSTEMS

## DUCT TYPE



Scan here to download the latest version of this manual.  
Σαρώστε εδώ για να κατεβάσετε την τελευταία έκδοση του εγχειριδίου.

