

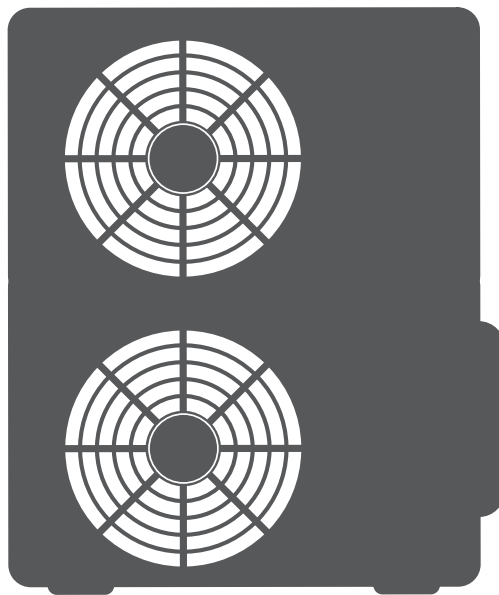

# AIR CONDITIONING SYSTEMS

## FLOOR STANDING

- **SERVICE MANUAL**

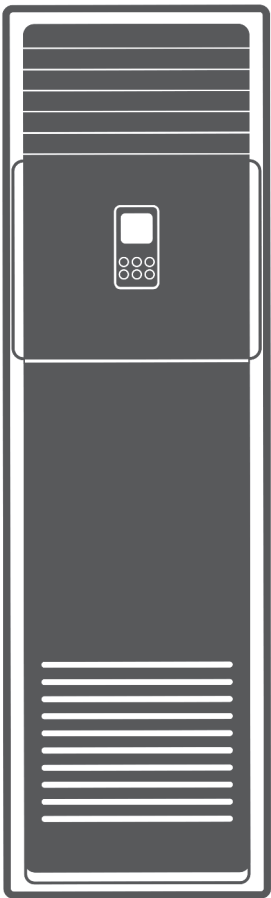

**MODELS:**  
V6FI-60/V6FO-60





---

## Table of Contents

---

### §. Safety Precautions

1. Precautions
2. Information servicing(For flammable materials)

### §. Specifications

1. Model Reference
2. Pipe length and the Drop Height
3. Electrical Wiring Diagrams

### §. Product Features

1. Display Function
2. Safety Features
3. Basic Features
4. Optional Features

### §. Maintenance

1. First Time Installation Check
2. Refrigerant Recharge
3. Re-Installation

### §. Indoor Unit Disassembly

1. Dimension
2. Indoor Unit Disassembly

### §. Outdoor Unit Disassembly

1. Outdoor Unit Table
2. Dimension
3. Outdoor Unit Disassembly

---

## Table of Contents

---

### §. Troubleshooting

1. Safety Caution
2. General Troubleshooting
3. Information Inquiry
4. Error Diagnosis and Troubleshooting Without Error Code
5. Quick Maintenance by Error Code
6. Troubleshooting by Error Code
7. Check Procedures

### Appendix

- i) Temperature Sensor Resistance Value Table for T1,T2,T3 and T4 (°C – K)
- ii) Temperature Sensor Resistance Value Table for TP(for some units) (°C – K)
- iii) Pressure On Service Port



**Caution: Risk of fire  
(Required for R32/R290  
units only)**

---

# Safety Precautions

## Contents

1.	Precautions.....	2
2.	Information servicing(For flammable materials).....	3

## 1. Precautions

To prevent personal injury, or property or unit damage, adhere to all precautionary measures and instructions outlined in this manual. Before servicing a unit, refer to this service manual and its relevant sections.

Failure to adhere to all precautionary measures listed in this section may result in personal injury, damage to the unit or to property, or in extreme cases, death.

 **WARNING** indicates a potentially hazardous situation which if not avoided could result in serious personal injury, or death.

 **CAUTION** indicates a potentially hazardous situation which if not avoided could result in minor or moderate personal injury, or unit damage.

### 1.1 In case of Accidents or Emergency

 **WARNING**

- If a gas leak is suspected, immediately turn off the gas and ventilate the area if a gas leak is suspected before turning the unit on.
- If strange sounds or smoke is detected from the unit, turn the breaker off and disconnect the power supply cable.
- If the unit comes into contact with liquid, contact an authorized service center.
- If liquid from the batteries makes contact with skin or clothing, immediately rinse or wash the area well with clean water.
- Do not insert hands or other objects into the air inlet or outlet while the unit is plugged in.
- Do not operate the unit with wet hands.
- Do not use a remote controller that has previously been exposed to battery damage or battery leakage.

 **CAUTION**

- Clean and ventilate the unit at regular intervals when operating it near a stove or near similar devices.
- Do not use the unit during severe weather conditions. If possible, remove the product from the window before such occurrences.

### 1.2 Pre-Installation and Installation

 **WARNING**

- Use this unit only on a dedicated circuit.
- Damage to the installation area could cause the unit to fall, potentially resulting in personal injury, property damage, or product failure.
- Only qualified personnel should disassemble, install, remove, or repair the unit.
- Only a qualified electrician should perform electrical work. For more information, contact your dealer, seller, or an authorized service center.

 **CAUTION**

- While unpacking be careful of sharp edges around the unit as well as the edges of the fins on the condenser and evaporator.

### 1.3 Operation and Maintenance

 **WARNING**

- Do not use defective or under-rated circuit breakers.
- Ensure the unit is properly grounded and that a dedicated circuit and breaker are installed.
- Do not modify or extend the power cable. Ensure the power cable is secure and not damaged during operation.
- Do not unplug the power supply plug during operation.
- Do not store or use flammable materials near the unit.
- Do not open the inlet grill of the unit during operation.
- Do not touch the electrostatic filter if the unit is equipped with one.
- Do not block the inlet or outlet of air flow to the unit.
- Do not use harsh detergents, solvents, or similar items to clean the unit. Use a soft cloth for cleaning.
- Do not touch the metal parts of the unit when removing the air filter as they are very sharp.
- Do not step on or place anything on the unit or outdoor units.
- Do not drink water drained from the unit
- Avoid direct skin contact with water drained from the unit.
- Use a firm stool or step ladder according to manufacturer procedures when cleaning or maintaining the unit.

 **CAUTION**

- Do not install or operate the unit for an extended period of time in areas of high humidity or in an environment directly exposing it to sea wind or salt spray.
- Do not install the unit on a defective or damaged installation stand, or in an unsecure location.
- Ensure the unit is installed at a level position
- Do not install the unit where noise or air discharge created by the outdoor unit will negatively impact the environment or nearby residences.
- Do not expose skin directly to the air discharged by the unit for prolonged periods of time.
- Ensure the unit operates in areas water or other liquids.
- Ensure the drain hose is installed correctly to ensure proper water drainage.
- When lifting or transporting the unit, it is recommended that two or more people are used for this task.
- When the unit is not to be used for an extended time, disconnect the power supply or turn off the breaker.

---

## 2. Information servicing(For flammable materials)

### 2.1 Checks to the area

- Prior to beginning work on systems containing flammable refrigerants, safety checks are necessary to ensure that the risk of ignition is minimized.
- For repair to the refrigerating system, the following precautions shall be complied with prior to conducting work on the system.

### 2.2 Work procedure

- Work shall be undertaken under a controlled procedure so as to minimise the risk of a flammable gas or vapour being present while the work is being performed.

### 2.3 Work procedure

- All maintenance staff and others working in the local area shall be instructed on the nature of work being carried out.
- Work in confined spaces shall be avoided.
- The area around the work space shall be sectioned off. Ensure that the conditions within the area have been made safe by control of flammable material.

### 2.4 Checking for presence of refrigerant

- The area shall be checked with an appropriate refrigerant detector prior to and during work, to ensure the technician is aware of potentially flammable atmospheres.
- Ensure that the leak detection equipment being used is suitable for use with flammable refrigerants, i.e. no sparking, adequately sealed or intrinsically safe.

### 2.5 Presence of fire extinguisher

- If any hot work is to be conducted on the refrigeration equipment or any associated parts, appropriate fire extinguishing equipment shall be available to hand.
- Have a dry powder or CO<sub>2</sub> fire extinguisher adjacent to the charging area.

### 2.6 No ignition sources

- No person carrying out work in relation to a refrigeration system which involves exposing any pipe work that contains or has contained flammable refrigerant shall use any sources of ignition in such a manner that it may lead to the risk of fire or explosion.
- All possible ignition sources, including cigarette smoking, should be kept sufficiently far away from the site of installation, repairing, removing and disposal, during which flammable refrigerant can possibly be released to the surrounding space.

- Prior to work taking place, the area around the equipment is to be surveyed to make sure that there are no flammable hazards or ignition risks.
- NO SMOKING signs shall be displayed.

### 2.7 Ventilated area

- Ensure that the area is in the open or that it is adequately ventilated before breaking into the system or conducting any hot work. A degree of ventilation shall continue during the period that the work is carried out. The ventilation should safely disperse any released refrigerant and preferably expel it externally into the atmosphere.

### 2.8 Checks to the refrigeration equipment

- Where electrical components are being changed, they shall be fit for the purpose and to the correct specification. At all times the manufacturer's maintenance and service guidelines shall be followed. If in doubt consult the manufacturer's technical department for assistance. The following checks shall be applied to installations using flammable refrigerants:
  - the charge size is in accordance with the room size within which the refrigerant containing parts are installed;
  - the ventilation machinery and outlets are operating adequately and are not obstructed;
  - if an indirect refrigerating circuit is being used, the secondary circuit shall be checked for the presence of refrigerant; marking to the equipment continues to be visible and legible.
  - markings and signs that are illegible shall be corrected;
  - refrigeration pipe or components are installed in a position where they are unlikely to be exposed to any substance which may corrode refrigerant containing components, unless the components are constructed of materials which are inherently resistant to being corroded or are suitably protected against being so corroded.

### 2.9 Checks to electrical devices

- Repair and maintenance to electrical components shall include initial safety checks and component inspection procedures. If a fault exists that could compromise safety, then no electrical supply shall be connected to the circuit until it is satisfactorily dealt with. If the fault cannot be corrected immediately but it is necessary to continue operation, an adequate temporary solution shall be used. This shall be reported to the owner of the equipment so all parties are advised. Initial safety checks shall include:

- that capacitors are discharged: this shall be done in a safe manner to avoid possibility of sparking;
- that there no live electrical components and wiring are exposed while charging, recovering or purging the system;
- that there is continuity of earth bonding.

## 2.10 Repairs to sealed components

- During repairs to sealed components, all electrical supplies shall be disconnected from the equipment being worked upon prior to any removal of sealed covers, etc. If it is absolutely necessary to have an electrical supply to equipment during servicing, then a permanently operating form of leak detection shall be located at the most critical point to warn of a potentially hazardous situation.
- Particular attention shall be paid to the following to ensure that by working on electrical components, the casing is not altered in such a way that the level of protection is affected. This shall include damage to cables, excessive number of connections, terminals not made to original specification, damage to seals, incorrect fitting of glands, etc.
  - Ensure that apparatus is mounted securely.
  - Ensure that seals or sealing materials have not degraded such that they no longer serve the purpose of preventing the ingress of flammable atmospheres. Replacement parts shall be in accordance with the manufacturer's specifications.

NOTE: The use of silicon sealant may inhibit the effectiveness of some types of leak detection equipment. Intrinsically safe components do not have to be isolated prior to working on them.

## 2.11 Repair to intrinsically safe components

- Do not apply any permanent inductive or capacitance loads to the circuit without ensuring that this will not exceed the permissible voltage and current permitted for the equipment in use. Intrinsically safe components are the only types that can be worked on while live in the presence of a flammable atmosphere. The test apparatus shall be at the correct rating.
- Replace components only with parts specified by the manufacturer. Other parts may result in the ignition of refrigerant in the atmosphere from a leak.

## 2.12 Cabling

- Check that cabling will not be subject to wear, corrosion, excessive pressure, vibration, sharp edges or any other adverse environmental effects. The check

shall also take into account the effects of aging or continual vibration from sources such as compressors or fans.

## 2.13 Detection of flammable refrigerants

- Under no circumstances shall potential sources of ignition be used in the searching for or detection of refrigerant leaks. A halide torch (or any other detector using a naked flame) shall not be used.

## 2.14 Leak detection methods

- The following leak detection methods are deemed acceptable for systems containing flammable refrigerants. Electronic leak detectors shall be used to detect flammable refrigerants, but the sensitivity may not be adequate, or may need re-calibration. (Detection equipment shall be calibrated in a refrigerant-free area.) Ensure that the detector is not a potential source of ignition and is suitable for the refrigerant used. Leak detection equipment shall be set at a percentage of the LFL of the refrigerant and shall be calibrated to the refrigerant employed and the appropriate percentage of gas (25 % maximum) is confirmed. Leak detection fluids are suitable for use with most refrigerants but the use of detergents containing chlorine shall be avoided as the chlorine may react with the refrigerant and corrode the copper pipe-work.
  - If a leak is suspected, all naked flames shall be removed or extinguished.
  - If a leakage of refrigerant is found which requires brazing, all of the refrigerant shall be recovered from the system, or isolated (by means of shut off valves) in a part of the system remote from the leak. Oxygen free nitrogen (OFN) shall then be purged through the system both before and during the brazing process.

## 2.15 Removal and evacuation

- When breaking into the refrigerant circuit to make repairs or for any other purpose, conventional procedures shall be used. However, it is important that best practice is followed since flammability is a consideration.
- The following procedure shall be adhered to:
  - remove refrigerant;
  - purge the circuit with inert gas;
  - evacuate;
  - purge again with inert gas;
  - open the circuit by cutting or brazing.



- The refrigerant charge shall be recovered into the correct recovery cylinders. The system shall be flushed with OFN to render the unit safe. This process may need to be repeated several times. Compressed air or oxygen shall not be used for this task. Flushing shall be achieved by breaking the vacuum in the system with OFN and continuing to fill until the working pressure is achieved, then venting to atmosphere, and finally pulling down to a vacuum. This process shall be repeated until no refrigerant is within the system. When the final OFN charge is used, the system shall be vented down to atmospheric pressure to enable work to take place. This operation is absolutely vital if brazing operations on the pipe-work are to take place.
- Ensure that the outlet for the vacuum pump is not close to any ignition sources and there is ventilation available.

## 2.16 Charging procedures

- In addition to conventional charging procedures, the following requirements shall be followed:
  - Ensure that contamination of different refrigerants does not occur when using charging equipment. Hoses or lines shall be as short as possible to minimize the amount of refrigerant contained in them.
  - Cylinders shall be kept upright.
  - Ensure that the refrigeration system is earthed prior to charging the system with refrigerant.
  - Label the system when charging is complete (if not already).
  - Extreme care shall be taken not to overfill the refrigeration system.
  - Prior to recharging the system it shall be pressure tested with OFN. The system shall be leak tested on completion of charging but prior to commissioning. A follow up leak test shall be carried out prior to leaving the site.

## 2.17 Decommissioning

Before carrying out this procedure, it is essential that the technician is completely familiar with the equipment and all its detail. It is recommended good practice that all refrigerants are recovered safely. Prior to the task being carried out, an oil and refrigerant sample shall be taken.

In case analysis is required prior to re-use of reclaimed refrigerant. It is essential that electrical power is available before the task is commenced.

- Become familiar with the equipment and its operation.
- Isolate system electrically.

- Before attempting the procedure ensure that:
  - mechanical handling equipment is available, if required, for handling refrigerant cylinders;
  - all personal protective equipment is available and being used correctly;
  - the recovery process is supervised at all times by a competent person;
  - recovery equipment and cylinders conform to the appropriate standards.
- Pump down refrigerant system, if possible.
- If a vacuum is not possible, make a manifold so that refrigerant can be removed from various parts of the system.
- Make sure that cylinder is situated on the scales before recovery takes place.
- Start the recovery machine and operate in accordance with manufacturer's instructions.
- Do not overfill cylinders. (No more than 80 % volume liquid charge).
- Do not exceed the maximum working pressure of the cylinder, even temporarily.
- When the cylinders have been filled correctly and the process completed, make sure that the cylinders and the equipment are removed from site promptly and all isolation valves on the equipment are closed off.
- Recovered refrigerant shall not be charged into another refrigeration system unless it has been cleaned and checked.

## 2.18 Labelling

- Equipment shall be labelled stating that it has been de-commissioned and emptied of
- refrigerant. The label shall be dated and signed. Ensure that there are labels on the equipment stating the equipment contains flammable refrigerant.

## 2.19 Recovery

- When removing refrigerant from a system, either for servicing or decommissioning, it is recommended good practice that all refrigerants are removed safely.
- When transferring refrigerant into cylinders, ensure that only appropriate refrigerant recovery cylinders are employed. Ensure that the correct numbers of cylinders for holding the total system charge are available. All cylinders to be used are designated for the recovered refrigerant and labelled for that refrigerant (i.e. special cylinders for the recovery of refrigerant). Cylinders shall be complete with pressure relief valve and associated shut-off valves in good working order.

- Empty recovery cylinders are evacuated and, if possible, cooled before recovery occurs.
- The recovery equipment shall be in good working order with a set of instructions concerning the equipment that is at hand and shall be suitable for the recovery of flammable refrigerants. In addition, a set of calibrated weighing scales shall be available and in good working order.
- Hoses shall be complete with leak-free disconnect couplings and in good condition. Before using the recovery machine, check that it is in satisfactory working order, has been properly maintained and that any associated electrical components are sealed to prevent ignition in the event of a refrigerant release. Consult manufacturer if in doubt.
- The recovered refrigerant shall be returned to the refrigerant supplier in the correct recovery cylinder, and the relevant Waste Transfer Note arranged. Do not mix refrigerants in recovery units and especially not in cylinders.
- If compressors or compressor oils are to be removed, ensure that they have been evacuated to an acceptable level to make certain that flammable refrigerant does not remain within the lubricant. The evacuation process shall be carried out prior to returning the compressor to the suppliers. Only electric heating to the compressor body shall be employed to accelerate this process. When oil is drained from a system, it shall be carried out safely.

---

# Specifications

## Contents

1.	Model Reference.....	2
2.	Pipe Length and Drop Height.....	3
3.	Electrical Wiring Diagrams.....	4

---

## 1. Model Reference

Refer to the following table to determine the specific indoor and outdoor unit model.

Indoor Unit Model	Outdoor Unit Model	Capacity (Btu/h)	Power Supply
V6FI-60	V6FO-60	48k	3 $\phi$ , 380~415V, 50Hz

## 2. Pipe Length and Drop Height

The length and elevation of connection pipe are shown in the table below. If the pipe length exceeds max pipe length, additional refrigerant should be charged to ensure nominal cooling/heating capacity.

Capacity(Btu/h)	Standard Length	Max Pipe Length	Max Elevation	Additional Refrigerant
48k	5m (16.4ft)	65m(213.25ft)	30m(98.4ft)	24g/m (0.26oz/ft)

If oil flows back into the outdoor unit's compressor, this might cause liquid compression or deterioration of oil return. Oil traps in the rising gas pipe can prevent this.

-An oil trap should be installed every 6m(20ft) of vertical suction line riser (<36000Btu/h unit).

-An oil trap should be installed every 10m(32.8ft) of vertical suction line riser ( $\geq$ 36000Btu/h unit).

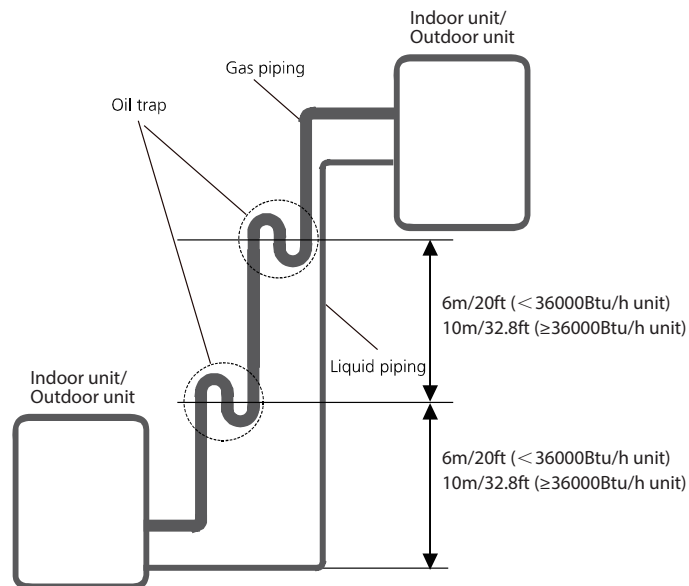

---

### 3. Electrical Wiring Diagrams

Indoor and outdoor unit wiring diagram

Indoor Unit		Outdoor Unit	
IDU Model	IDU Wiring Diagram	ODU Model	ODU Wiring Diagram
V6FI-60	16022200009897	V6FO-60	16022000033470

Outdoor unit printed circuit board diagram

Outdoor Unit		
ODU Model	ODU Printed Circuit Board	Inverter module printed board
V6FO-60	17122000041841	17122000021912

---

Indoor unit abbreviations

Abbreviation	Paraphrase
Y/G	Yellow-Green Conductor
HOR-SW	Horizontal Fan
VER-SW	Vertical Fan
L	LIVE
N	NEUTRAL
T1	Indoor Room Temperature
T2	Coil Temperature of Indoor Heat Exchanger

Outdoor unit abbreviations

Abbreviation	Paraphrase
COMP	Compressor
CAP1,CAP2	Fan Motor Capacitor
CT1	AC Current Detector
EEV	Electric Expansion Valve
DC FAN1,DC FAN2	Outdoor DC Fan
AC FAN1,AC FAN2	Outdoor AC Fan
HEAT_Y,HEAT_D	Crankcase Heating
H-PRO	High Pressure Switch
L-PRO	Low Pressure Switch
SV	4-Way Valve
TP	Exhaust Temperature Sensor
T3	Condenser Temperature Sensor
T4	Outdoor Ambient Temperature Sensor
TH	Heatsink Temperature Sensor

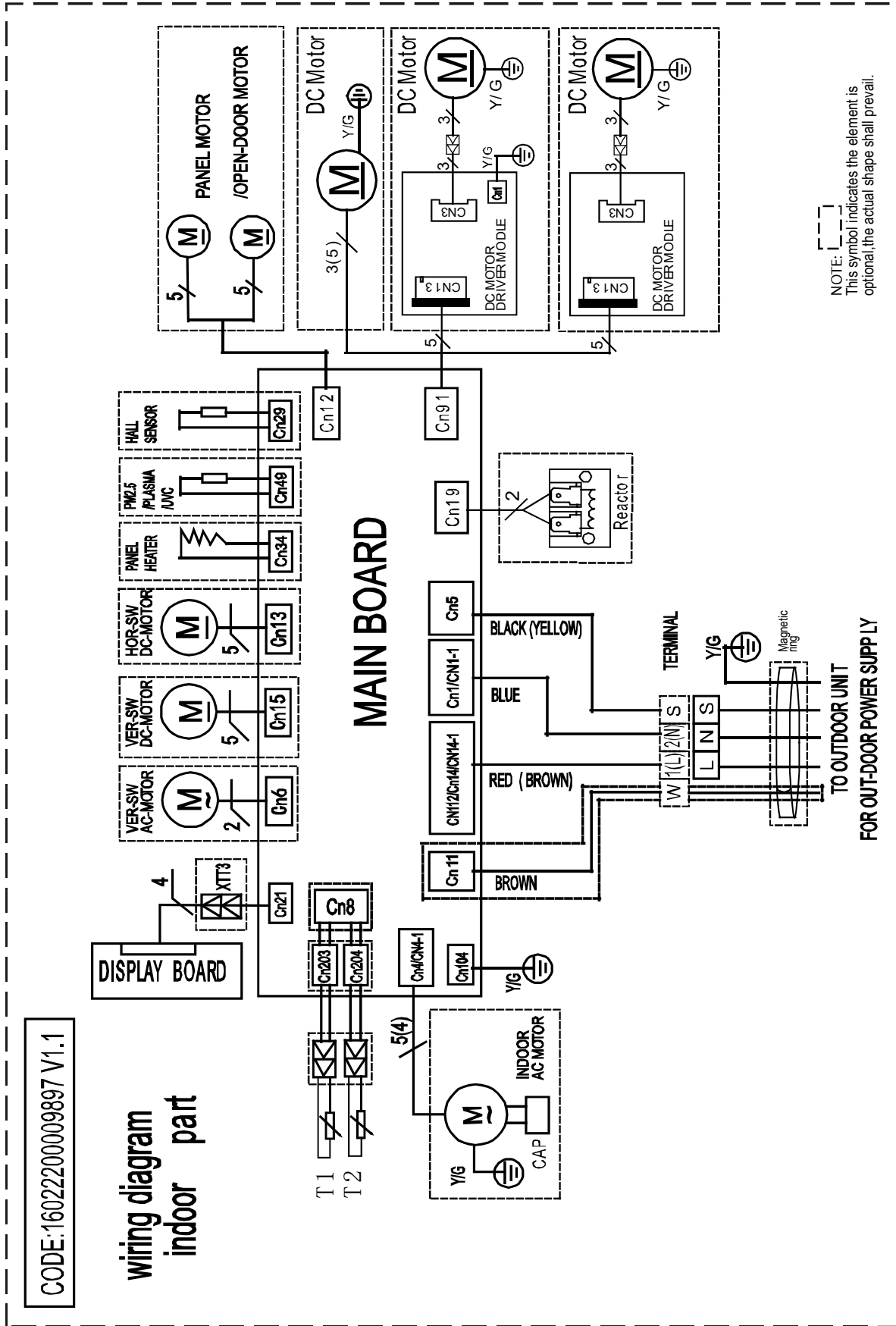



Outdoor unit wiring diagram: 16022000033470

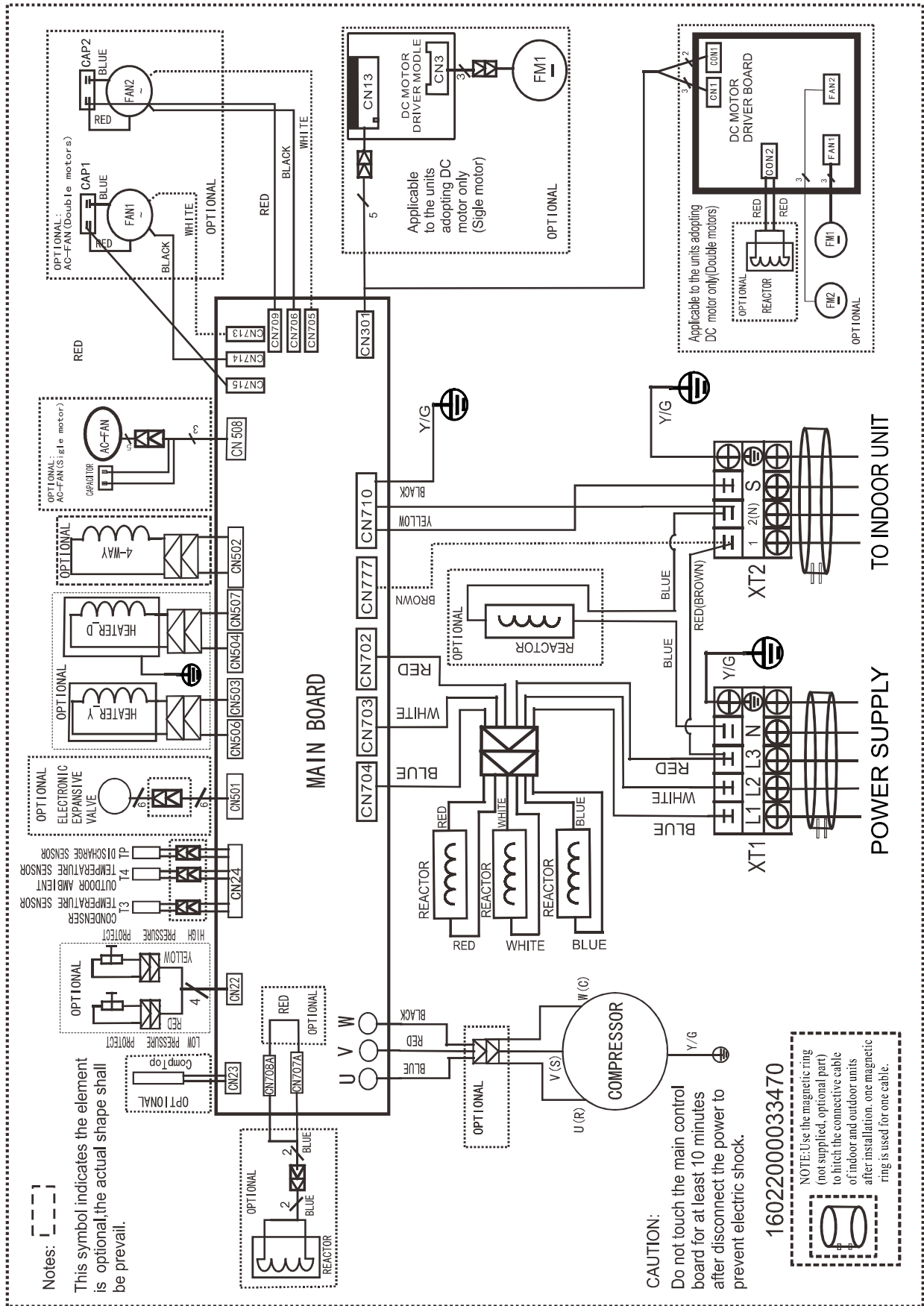

Outdoor unit printed circuit board diagram: 17122000041841

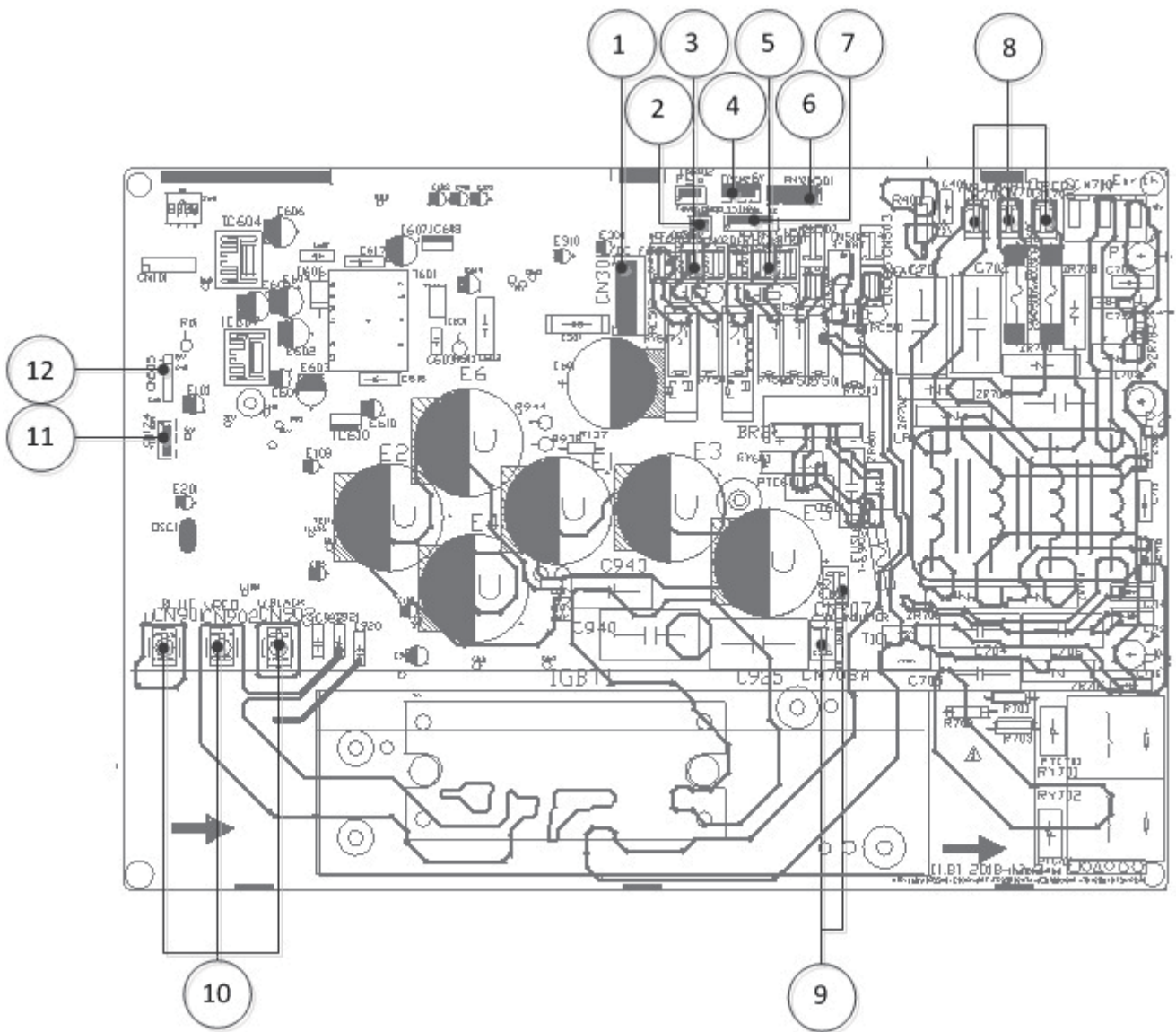

No.	Name	CN#	Meaning
1	CN301	CN301	Connect to DC fan motor
2	CN23	CN23	Connect to Comp Top
3	CN705	CN705	Connect to AC fan motor
	CN706	CN706	Connect to AC fan motor
	CN709	CN709	Connect to AC fan motor
4	CN22	CN22	Connect to high/low pressure protect
5	CN715	CN715	Connect to AC fan motor
	CN714	CN714	
	CN714	CN714	
6	CN501	CN501	Connect to electronic expansive valve
7	CN24	CN24	Connect to condenser temperature, outdoor ambient and discharge sensor
8	CN704	CN704	Power Supply (L1)
	CN703	CN703	Power Supply (L2)
	CN702	CN702	Power Supply (L3)
9	CN708A	CN708A	Connect to reactor
	CN707A	CN707A	
10	U	U	Connect to compressor
	V	V	
	W	W	
11	CN174	CN174	Test port
12	CN505	CN505	EEprom port

**Note: This section is for reference only. Please take practicality as standard.**

Outdoor unit DC motor driver board diagram: 17122000021912

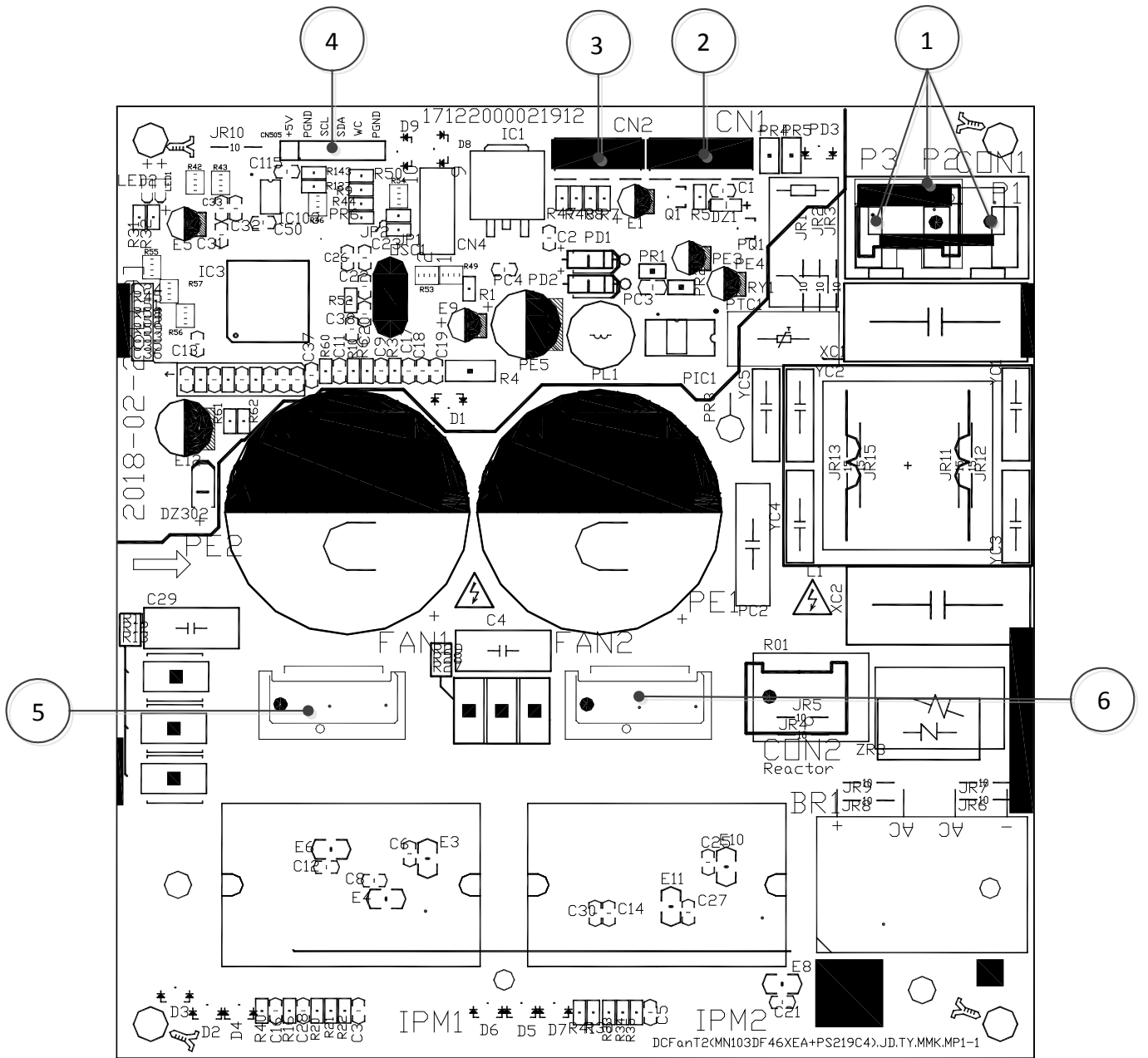

---

No.	Name	CN#	Meaning
1	POWER	CON1	Power supply 208-230V AC
		P2	
		P3	
2	CN1	CN1	connect to main board
3	TESTPORT	CN2	used for testing
4	CN505	CN505	connect to PC communication
5	FAN1	FAN1	connect to DC fan1
6	FAN2	FAN2	connect to DC fan2

---

---

# Product Features

## Contents

<b>1.</b>	<b>Display Function .....</b>	<b>2</b>
<b>2</b>	<b>Safety Features .....</b>	<b>3</b>
<b>3.</b>	<b>Basic Functions.....</b>	<b>4</b>
3.1	Table .....	4
3.2	Abbreviation.....	4
3.3	Fan Mode.....	4
3.4	Cooling Mode .....	4
3.5	Heating Mode .....	5
3.6	Auto-mode.....	6
3.7	Drying Mode .....	6
3.8	Sleep Function .....	6
<b>4.</b>	<b>Optional Functions .....</b>	<b>7</b>

# 1. Display Function



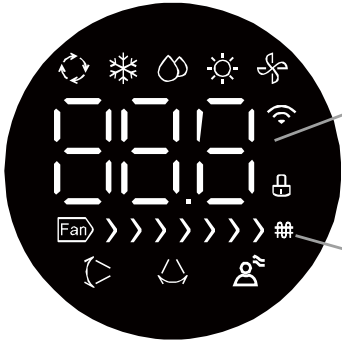





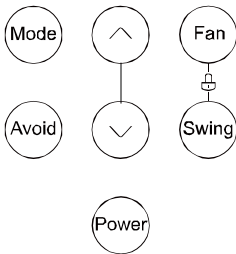

Unit display functions



Room Temp/Set Temp/Set Timer display

Fan speed operation display



-  Auto operation
-  Cooling operation
-  Dry operation
-  Heating operation
-  Fan operation
-  Vertical airflow
-  Horizontal airflow
-  Avoid direct
-  When wireless control feature is activated(some models)
-  Electric heating function(some models)
-  Lock operation

---

## 2. Safety Features

### Compressor three-minute delay at restart

Compressor functions are delayed for up to three minutes upon subsequent unit restarts.

### Automatic shutoff based on discharge temperature

If the compressor discharge temperature exceeds a certain level for a period of time, the compressor ceases operation.

### Inverter module protection

The inverter module has an automatic shutoff mechanism based on the unit's current, voltage, and temperature. If automatic shutoff is initiated, the corresponding error code is displayed on the indoor unit and the unit ceases operation.

### Indoor fan delayed operation

- When the unit starts, the louver is automatically activated and the indoor fan will operate after a period of setting time.
- If the unit is in heating mode, the indoor fan is regulated by the anti-cold wind function.

### Sensor redundancy and automatic shutoff

- If one temperature sensor malfunctions, the air conditioner continues operation and displays the corresponding error code, allowing for emergency use.
- When more than one temperature sensor is malfunctioning, the air conditioner ceases operation.

### Refrigerant leakage detection(for some models)

It will detect if the compressor is being damaged by refrigerant leakage or by compressor overload. This is measured using the coil temperature of evaporator T2 and Indoor room temperature T1 when the compressor is in operation.

### Low pressure check function(for some models)

The low pressure switch should be always closed. If it is open, the air conditioner ceases operation until the fault is cleared.



---

### 3. Basic Functions

#### 3.1 Table

Functions		Cooling Mode&Heating mode		Auto Mode	
		Outdoor Fan Control			
Cases		Case 1: Compressor Frequency and T4	Case 2:T4	Case 1:	Case 2:
Models	48K	✓			✓

**Note:** The detailed description of case 1 or case 2 is shown in the following function sections(from 3.4 to 3.6).

## 3.2 Abbreviation

Unit element abbreviations

Abbreviation	Element
T1	Indoor room temperature
T2	Coil temperature of evaporator
T3	Coil temperature of condenser
T4	Outdoor ambient temperature
TS	Set temperature
TP	Compressor discharge temperature

In this manual, such as CDIFTEMP, HDIFTEMP2, TCE1, TCE2...etc., they are well-setting parameter of EEPROM.

## 3.3 Fan Mode

When fan mode is activated:

- The outdoor fan and compressor are stopped.
- Temperature control is disabled and no temperature setting is displayed.
- The indoor fan speed can be set to high, low, or auto.
- The louver operations are identical to those in cooling mode.
- Auto fan: In fan-only mode, AC operates the same as auto fan in cooling mode with the temperature set at 24°C.

## 3.4 Cooling Mode

### 3.4.1 Compressor Control

Reach the configured temperature:

- 1) When the compressor runs continuously for less than 120 minutes.
  - If the following conditions are satisfied, the compressor ceases operation.
    - While calculated frequency(fb) is less than minimum limit frequency(FminC).
    - While protective time is more than or equal to ten minutes.
    - While T1 is lower than or equal to (Tsc-CDIFTEMP-0.5°C)

Note: CDIFTEMP is EEPROM setting parameter. It is 2°C usually.

- 2) When the compressor runs continuously for more than 120 minutes.
  - If the following conditions are satisfied, the

compressor ceases operation.

- When calculated frequency(fb) is less than minimum limit frequency(FminC).
- When protective time is more than or equal to ten minutes.
- When T1 is lower than or equal to (Tsc-CDIFTEMP).

Note: CDIFTEMP is EEPROM setting parameter. It is 2°C usually.

- 3) If one of the following conditions is satisfied, not judge protective time.
  - Compressor running frequency is more than test frequency.
  - When compressor running frequency is equal to test frequency, T4 is higher than 15°C or T4 sensor fault
  - Change setting temperature.
  - Turbo function on/off
  - Various frequency limit shutdown occurs.

### 3.4.2 Indoor Fan Control

- In cooling mode, the indoor fan operates continuously. The fan speed can be set to high, (medium), low, or auto.
- Auto fan in cooling mode:

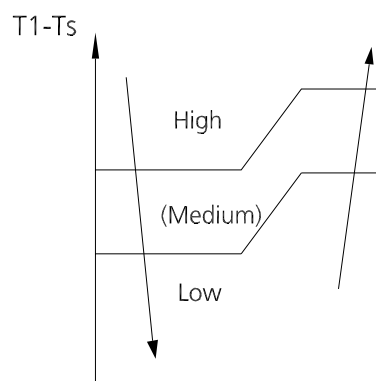

### 3.4.3 Outdoor Fan Control

#### Case 1:

- The outdoor unit will be run at different fan speed according to T4 and compressor frequency.
- For different outdoor units, the fan speeds are different.

#### Case 2:

- The outdoor unit will be run at different fan speed according to T4.
- For different outdoor units, the fan speeds are different.

### 3.4.4 Condenser Temperature Protection

When condenser temperature is more than setting value, the compressor ceases operation..

### 3.4.5 Evaporator Temperature Protection

When evaporator temperature drops below a configured value, the compressor and outdoor fan cease operation.

## 3.5 Heating Mode(Heat pump units)

### 3.5.1 Compressor Control

1) Reach the configured temperature

- If the following conditions are satisfied, the compressor ceases operation.
  - While calculated frequency(fb) is less than minimum limit frequency(FminH).
  - When protective time is more than or equal to ten minutes.
  - When T1 is higher than or equal to Tsc+ HDIFTEMP2.

Note: HDIFTEMP2 is EEPROM setting parameter. It is 2°C usually.

- If one of the following conditions is satisfied, not judge protective time.
    - Compressor running frequency is more than test frequency.
    - When compressor running frequency is equal to test frequency, T4 is higher than 15°C or T4 sensor fault.
    - Change setting temperature.
    - Turbo function on/off.
- 2) When the current is higher than the predefined safe value, surge protection is activated, causing the compressor to cease operation.

### 3.5.2 Indoor Fan Control:

- When the compressor is on, the indoor fan speed can be set to high, (medium) ,low, or auto. And the anti-cold wind function has the priority.
- Anti-cold air function
  - The indoor fan is controlled by the indoor unit coil temperature T2.

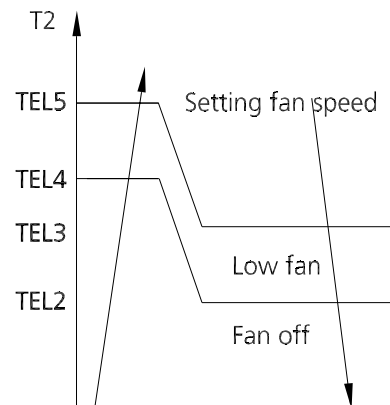

- Auto fan action in heating mode:

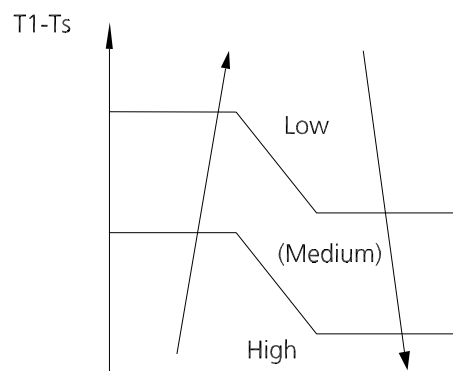

### 3.5.3 Outdoor Fan Control:

#### Case 1:

- The outdoor unit will be run at different fan speed according to T4 and compressor frequency.
- For different outdoor units, the fan speeds are different.

#### Case 2:

- The outdoor unit will be run at different fan speed according to T4.
- For different outdoor units, the fan speeds are different.

### 3.5.4 Defrosting mode

- The unit enters defrosting mode according to the temperature value of T3 and T4 as well as the compressor running time.
- In defrosting mode, the compressor continues to run, the indoor and outdoor motor will cease operation, the defrost light of the indoor unit will turn on, and the "df" symbol is displayed.
- If any one of the following conditions is satisfied, defrosting ends and the machine switches to normal heating mode:
  - T3 rises above TCDE1.

- T3 maintained above TCDE2 for 80 seconds.
- Unit runs for 15 minutes consecutively in defrosting mode.
- If T4 is lower than or equal to -22°C and compressor running time is more than TIMING\_DEFROST\_TIME, if any one of the following conditions is satisfied, defrosting ends and the machine switches to normal heating mode:
  - Unit runs for 10 minutes consecutively in defrosting mode.
  - T3 rises above 10°C.

For some models,

- T3 is lower than 3°C and compressor running time is more than 120 minutes, at this time, if T3 is lower than TCDI1+4°C(39.2°F) for 3 minutes. If any one of the following conditions is satisfied, defrosting ends and the machine switches to normal heating mode:
  - T3 rises above TCDE1+4°C.
  - T3 maintained above TCDE2+4°C for 80 seconds.
  - Unit runs for 15 minutes consecutively in defrosting mode.

### 3.5.5 Evaporator Temperature Protection

When the evaporator temperature exceeds a preset protection value, the compressor ceases operation.

### 3.6 Auto-mode

- This mode can be selected with the remote controller and the setting temperature can be changed between 16°C~30°C.

#### Case 1:

- In auto mode, the machine selects cooling, heating, or fan-only mode on the basis of  $\Delta T$  ( $\Delta T = T1 - Ts$ ).

$\Delta T$	Running mode
$\Delta T > A$	Cooling
$B < \Delta T \leq A$	Fan-only
$\Delta T < B$	Heating*

Heating\*: In auto mode, cooling only models run the fan

- Indoor fan will run at auto fan speed.
- The louver operates same as in relevant mode.
- If the machine switches mode between heating and cooling, the compressor will keep stopping for certain time and then choose mode according to  $\Delta T$ .

#### Case 2:

- In auto mode, the machine selects cooling, heating, or fan-only mode on the basis of T1, Ts and T4.

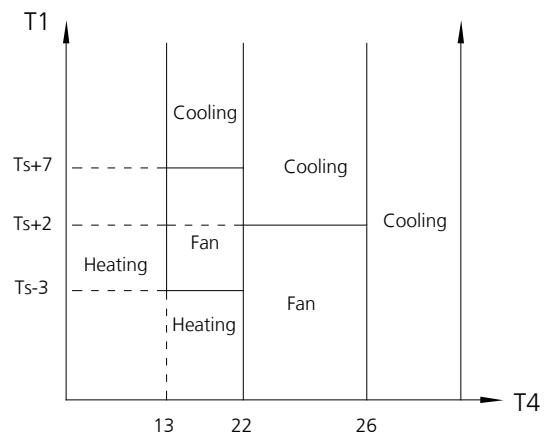

- If the setting temperature is modified, the machine selects a new running function.

### 3.7 Drying mode

- AC operates the same as auto fan in cooling mode.
- When  $T1 < 17^\circ\text{C}$ , the fan speed is lower than 30%, the unit will operate at 30%.
- Low Room Temperature Protection
  - If the room temperature is lower than 10°C, the compressor ceases operations and does not resume until room temperature exceeds 12°C.
- All protections are active and the same as that in cooling mode.

### 3.8 Sleep function

- The sleep function is available in cooling, heating, or auto mode.
- The operational process for sleep mode is as follows:
  - When cooling, the temperature rises 1°C(2°F) (to not higher than 30°C(86°F)) every hour. After 2 hours, the temperature stops rising and the indoor fan is fixed at low speed.
  - When heating, the temperature decreases 1°C(2°F) (to not lower than 16°C(60.8°F)) every hour. After 2 hours, the temperature stops decreasing and the indoor fan is fixed at low speed. Anti-cold wind function takes priority.
- The unit exits sleep operation when it receives the following signals:
  - Switch off
  - Turbo
  - Silence
  - Self-clean
  - Changes in:
    - mode
    - fan speed

---

## 4. Optional Functions

### 4.1 8°C Heating

In heating mode, the temperature can be set to as low as 8°C, preventing the indoor area from freezing if unoccupied during severe cold weather.

### 4.2 Self clean

- If you press “Self Clean” when the unit is in cooling or drying mode:
  - The indoor unit will run in low fan mode for a certain time, then ceases operation.
- Self Clean keeps the indoor unit dry and prevents mold growth.
- When match with multi outdoor unit, this function is disabled.

### 4.3 Follow me

- If you press “Follow Me” on the remote, the indoor unit will beep. This indicates the follow me function is active.
- Once active, the remote control will send a signal every 3 minutes, with no beeps. The unit automatically sets the temperature according to the measurements from the remote control.
- The unit will only change modes if the information from the remote control makes it necessary, not from

the unit’s temperature setting.

- If the unit does not receive a signal for 7 minutes or you press “Follow Me,” the function turns off. The unit regulates temperature based on its own sensor and settings.

### 4.4 Silence

- Press “Silence” on the remote control to enable the SILENCE function. While this function is active, the compressor frequency is maintained at a lower level than F3. The indoor unit will run at faint breeze, which reduces noise to the lowest possible level.
- When match with multi outdoor unit, this function is disabled.

### 4.5 Auto-Restart function

- The indoor unit has an auto-restart module that allows the unit to restart automatically. The module automatically stores the current settings and, in the case of a sudden power failure, will restore those setting automatically after power returns.

### 4.6 Refrigerant Leakage Detection

With this new technology, the display area will show “EC” or “EL 0C” when the outdoor unit detects refrigerant leakage.

---

# Maintenance

## Contents

<b>1.</b>	<b>First Time Installation Check</b> .....	<b>2</b>
<b>2</b>	<b>Refrigerant Recharge</b> .....	<b>4</b>
<b>3</b>	<b>Re-Installation</b> .....	<b>5</b>
3.1	Indoor Unit.....	5
3.2	Outdoor Unit.....	7

## 1. First Time Installation Check

Air and moisture trapped in the refrigerant system affects the performance of the air conditioner by:

- Increasing pressure in the system.
- Increasing the operating current.
- Decreasing the cooling or heating efficiency.
- Congesting the capillary tubing due to ice build-up in the refrigerant circuit.
- Corroding the refrigerant system.

To prevent air and moisture from affecting the air conditioner's performance, the indoor unit, as well as the pipes between the indoor and outdoor unit, must be leak tested and evacuated.

### Leak test (soap water method)

Use a soft brush to apply soapy water or a neutral liquid detergent onto the indoor unit connections and outdoor unit connections. If there is gas leakage, bubbles will form on the connection.

### Air purging with vacuum pump

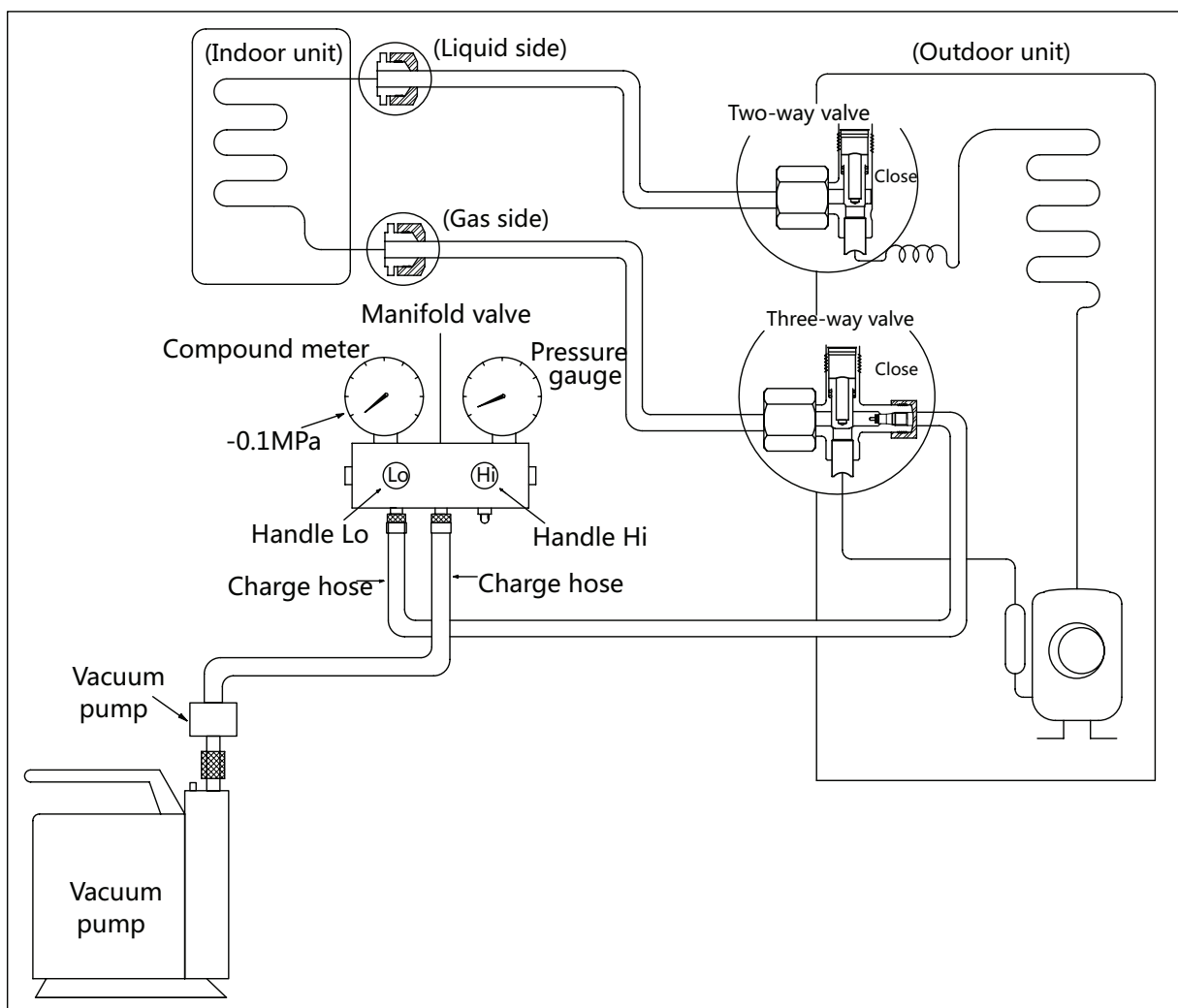

---

**Procedure:**

1. Tighten the flare nuts of the indoor and outdoor units, and confirm that both the 2- and 3-way valves are closed.
2. Connect the charge hose with the push pin of Handle Lo to the gas service port of the 3-way valve.
3. Connect another charge hose to the vacuum pump.
4. Fully open the Handle Lo manifold valve.
5. Using the vacuum pump, evacuate the system for 30 minutes.
  - a. Check whether the compound meter indicates -0.1 MPa (14.5 Psi).
    - If the meter does not indicate -0.1 MPa (14.5 Psi) after 30 minutes, continue evacuating for an additional 20 minutes.
    - If the pressure does not achieve -0.1 MPa (14.5 Psi) after 50 minutes, check for leakage.
- If the pressure successfully reaches -0.1 MPa (14.5 Psi), fully close the Handle Lo valve, then cease vacuum pump operations.
- b. Wait for 5 minutes then check whether the gauge needle moves after turning off the vacuum pump. If the gauge needle moves backward, check whether there is gas leakage.
6. Loosen the flare nut of the 3-way valve for 6 or 7 seconds and then tighten the flare nut again.
  - a. Confirm the pressure display in the pressure indicator is slightly higher than the atmospheric pressure.
  - b. Remove the charge hose from the 3-way valve.
7. Fully open the 2- and 3-way valves and tighten the cap of the 2- and 3-way valves.



## 2. Refrigerant Recharge

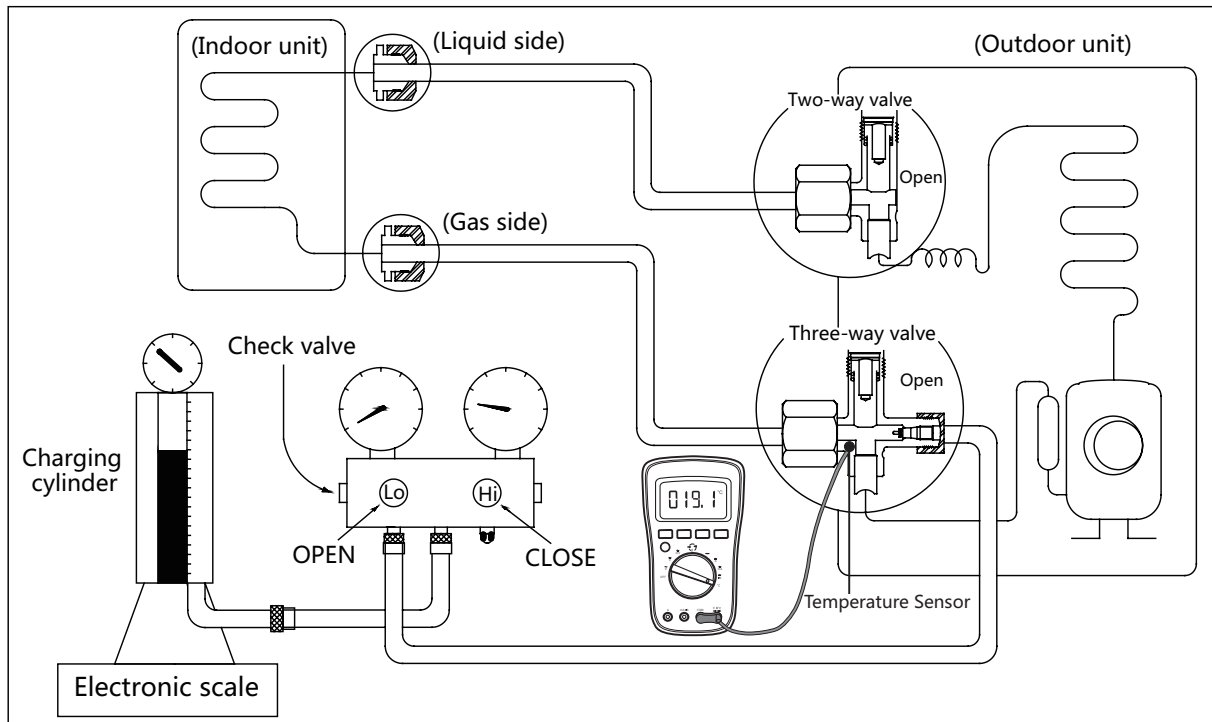

### Procedure:

1. Close both 2- and 3-way valves.
2. Slightly connect the Handle Lo charge hose to the 3-way service port.
3. Connect the charge hose to the valve at the bottom of the cylinder.
4. If the refrigerant is R410A/R32, invert the cylinder to ensure a complete liquid charge.
5. Open the valve at the bottom of the cylinder for 5 seconds to purge the air in the charge hose, then fully tighten the charge hose with push pin Handle Lo to the service port of 3-way valve..
6. Place the charging cylinder onto an electronic scale and record the starting weight.
7. Fully open the Handle Lo manifold valve, 2- and 3-way valves.
8. Operate the air conditioner in cooling mode to charge the system with liquid refrigerant.
9. When the electronic scale displays the correct weight (refer to the gauge and the pressure of the low side to confirm, the value of pressure refers to chapter Appendix), turn off the air conditioner, then disconnect the charge hose from the 3-way service port immediately..
10. Mount the caps of service port and 2- and 3-way valves.
11. Use a torque wrench to tighten the caps to a torque of 18 N.m.
12. Check for gas leakage.

## 3. Re-Installation

### 3.1 Indoor Unit

Collecting the refrigerant into the outdoor unit

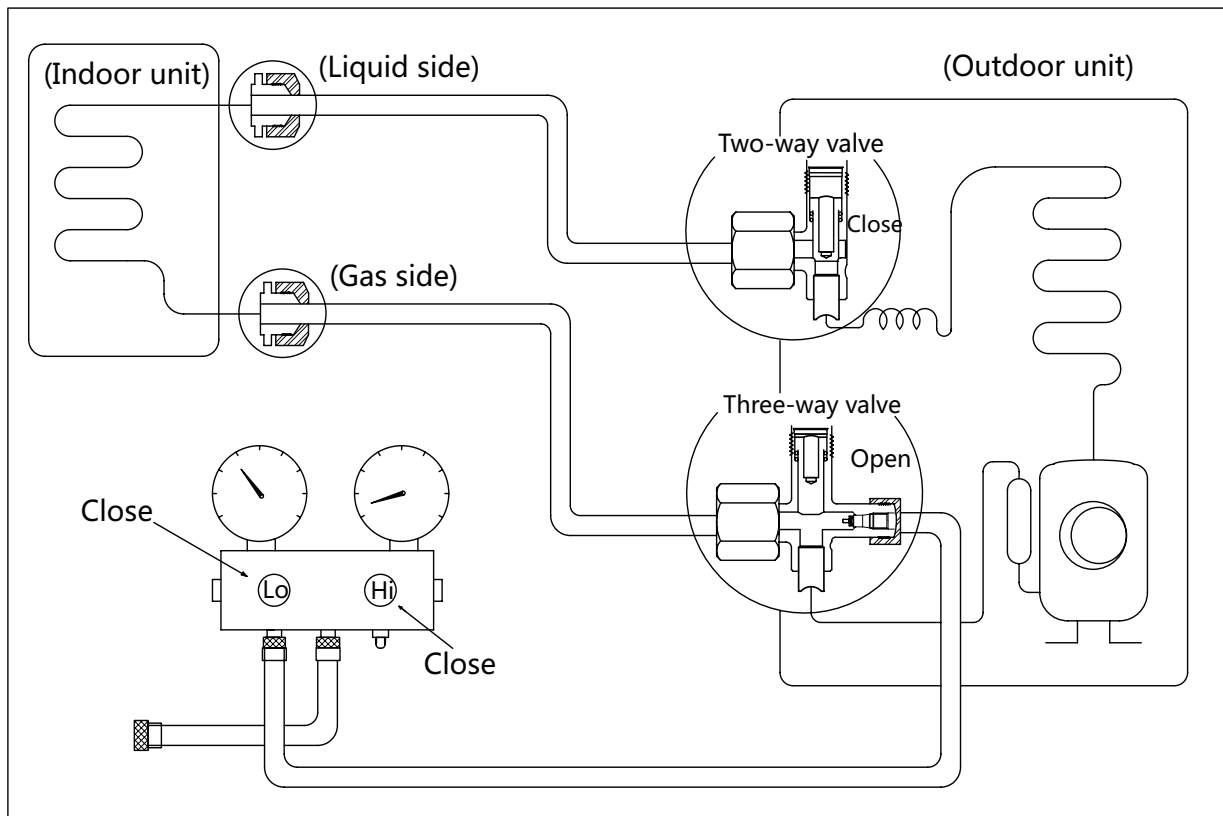

#### Procedure:

1. Confirm that the 2- and 3-way valves are opened.
2. Connect the charge hose with the push pin of Handle Lo to the 3-way valve's gas service port.
3. Open the Handle Lo manifold valve to purge air from the charge hose for 5 seconds and then close it quickly.
4. Close the 2-way valve.
5. Operate the air conditioner in cooling mode. Cease operations when the gauge reaches 0.1 MPa (14.5 Psi).
6. Close the 3-way valve so that the gauge rests between 0.3 MPa (43.5 Psi) and 0.5 MPa (72.5 Psi).
7. Disconnect the charge set and mount the caps of service port and 2- and 3-way valves.
8. Use a torque wrench to tighten the caps to a torque of 18 N.m.
9. Check for gas leakage.

## Air purging with vacuum pump

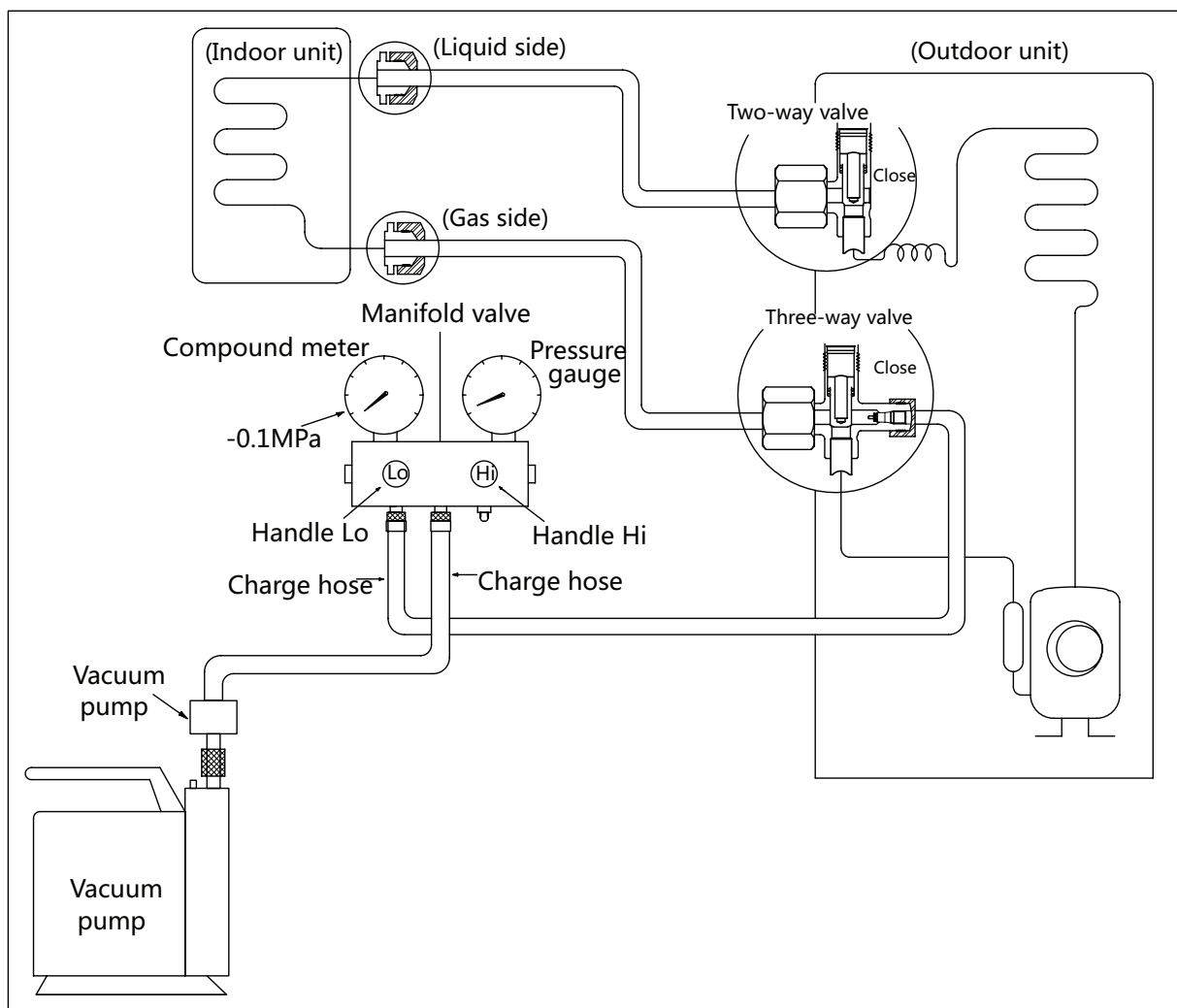

### Procedure:

1. Tighten the flare nuts of the indoor and outdoor units, and confirm that both the 2- and 3-way valves are closed.
2. Connect the charge hose with the push pin of Handle Lo to the gas service port of the 3-way valve.
3. Connect another charge hose to the vacuum pump.
4. Fully open the Handle Lo manifold valve.
5. Using the vacuum pump, evacuate the system for 30 minutes.
  - a. Check whether the compound meter indicates -0.1 MPa (14.5 Psi).
    - If the meter does not indicate -0.1 MPa (14.5 Psi) after 30 minutes, continue evacuating for an additional 20 minutes.
    - If the pressure does not achieve -0.1 MPa (14.5 Psi) after 50 minutes, check for leakage.
  - b. If the pressure successfully reaches -0.1 MPa (14.5 Psi), fully close the Handle Lo valve, then cease vacuum pump operations.
6. Loosen the flare nut of the 3-way valve for 6 or 7 seconds and then tighten the flare nut again.
  - a. Confirm the pressure display in the pressure indicator is slightly higher than the atmospheric pressure.
  - b. Remove the charge hose from the 3-way valve.
7. Fully open the 2- and 3-way valves and tighten the cap of the 2- and 3-way valves.

## 3.2 Outdoor Unit

### Evacuation for the whole system

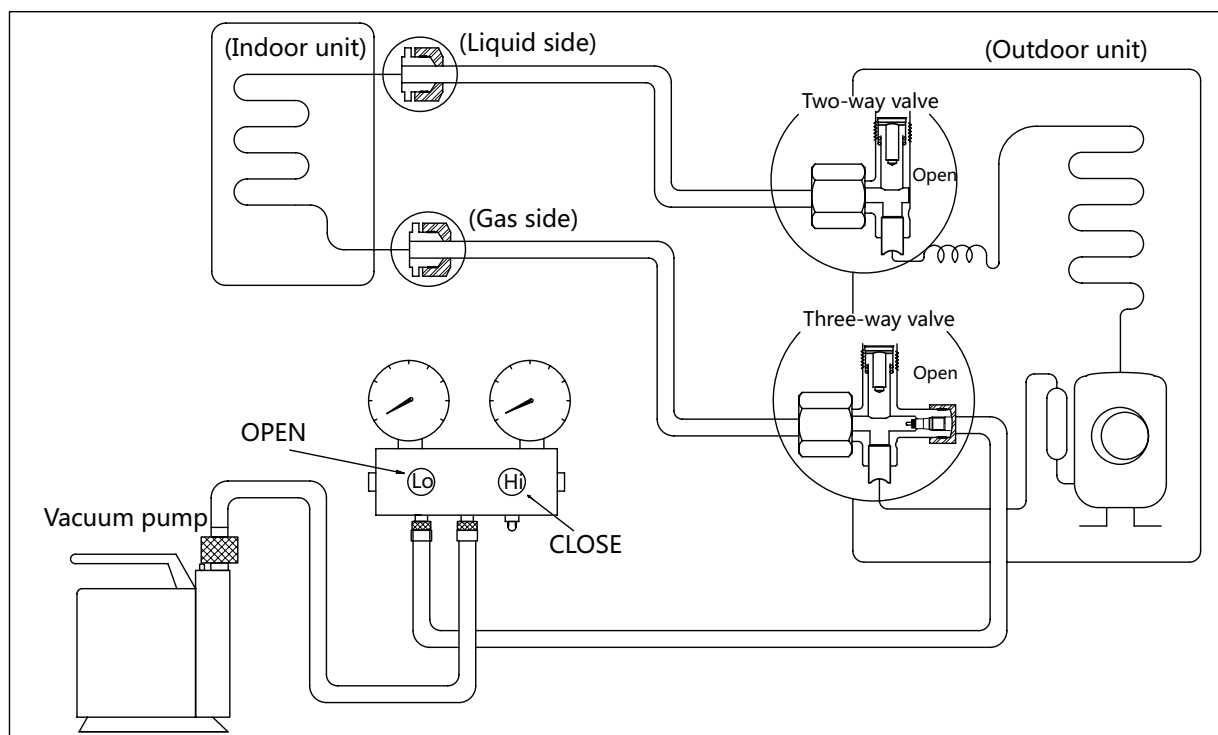

#### Procedure:

1. Confirm that the 2- and 3-way valves are opened.
2. Connect the vacuum pump to the 3-way valve's service port.
3. Evacuate the system for approximately one hour. Confirm that the compound meter indicates -0.1 MPa (14.5Psi).
4. Close the valve (Low side) on the charge set and turn off the vacuum pump.
5. Wait for 5 minutes then check whether the gauge needle moves after turning off the vacuum pump. If the gauge needle moves backward, check whether there is gas leakage.
6. Disconnect the charge hose from the vacuum pump.
7. Mount the caps of service port and 2- and 3-way valves.
8. Use a torque wrench to tighten the caps to a torque of 18 N.m.

## Refrigerant charging

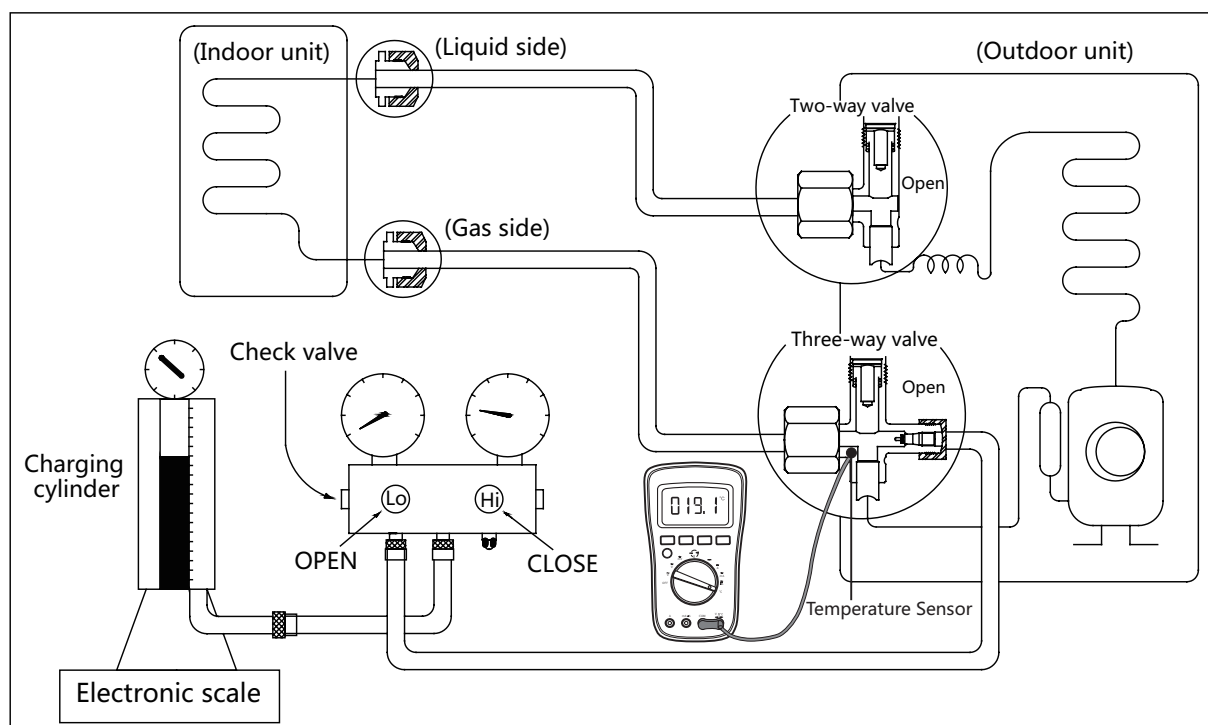

### Procedure:

1. Close both 2- and 3-way valves.
2. Slightly connect the Handle Lo charge hose to the 3-way service port.
3. Connect the charge hose to the valve at the bottom of the cylinder.
4. If the refrigerant is R410A/R32, invert the cylinder to ensure a complete liquid charge.
5. Open the valve at the bottom of the cylinder for 5 seconds to purge the air in the charge hose, then fully tighten the charge hose with push pin Handle Lo to the service port of 3-way valve..
6. Place the charging cylinder onto an electronic scale and record the starting weight.
7. Fully open the Handle Lo manifold valve, 2- and 3-way valves.
8. Operate the air conditioner in cooling mode to charge the system with liquid refrigerant.
9. When the electronic scale displays the correct weight (refer to the gauge and the pressure of the low side to confirm, the value of pressure refers to chapter Appendix), turn off the air conditioner, then disconnect the charge hose from the 3-way service port immediately..
10. Mount the caps of service port and 2- and 3-way valves.
11. Use a torque wrench to tighten the caps to a torque of 18 N.m.
12. Check for gas leakage.

**Note: 1. Mechanical connectors used indoors shall comply with local regulations.**

**2. When mechanical connectors are reused indoors, sealing parts shall be renewed. When flared joints are reused indoors, the flare part shall be re-fabricated.**

---

# Indoor Unit Disassembly

## Contents

<b>1.</b>	<b>Dimension .....</b>	<b>2</b>
<b>2.</b>	<b>Indoor Unit Disassembly .....</b>	<b>3</b>
2.1	Filter .....	3
2.2	Air inlet grille assembly .....	4
2.3	Air outlet grille assembly.....	5
2.4	Display board .....	7
2.5	Step motor .....	8
2.6	Electric parts.....	10
2.7	Fan motor .....	12
2.8	Evaporator.....	14

## 1. Dimension

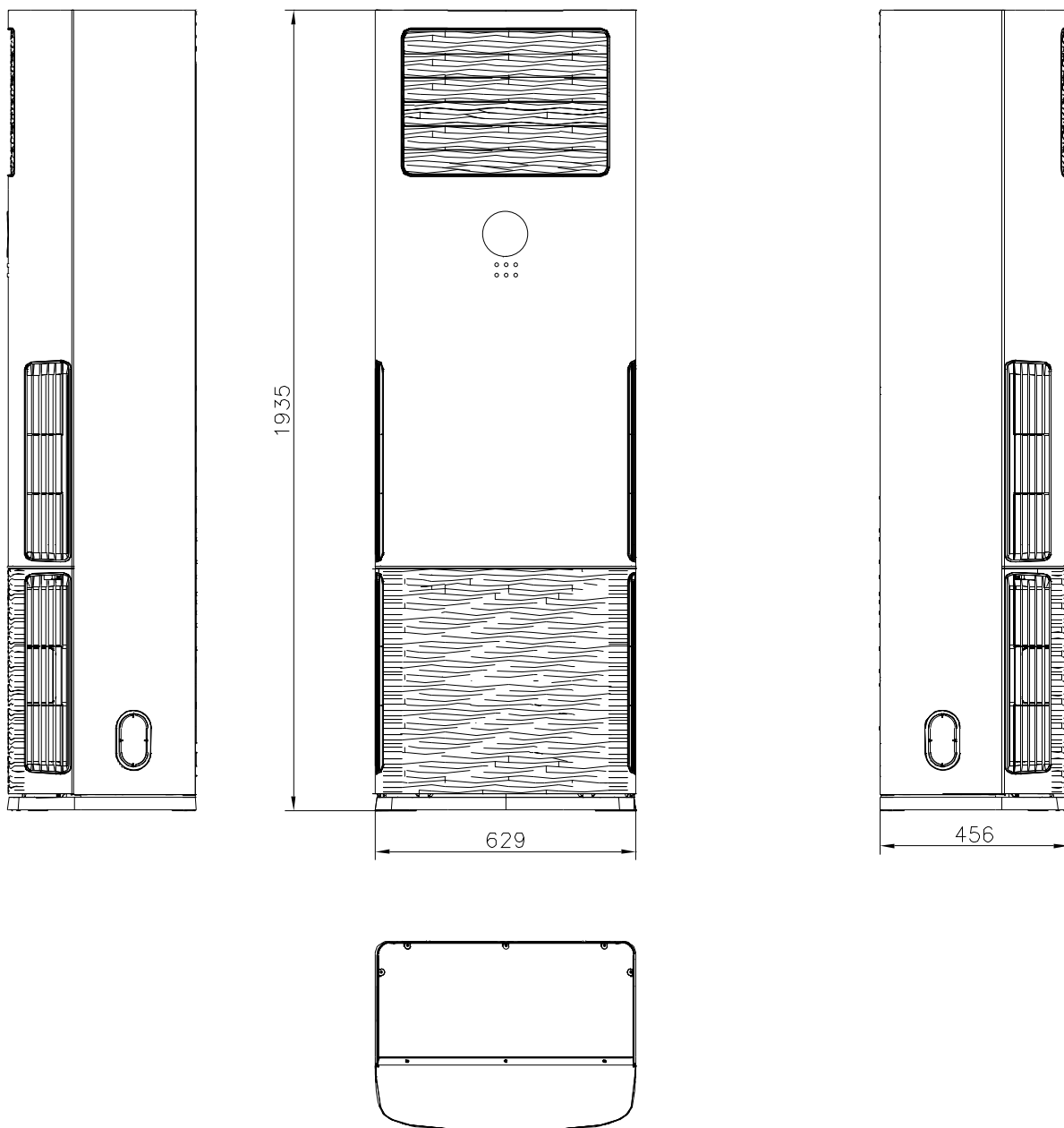

## 2. Disassembly

### 2.1 Filter

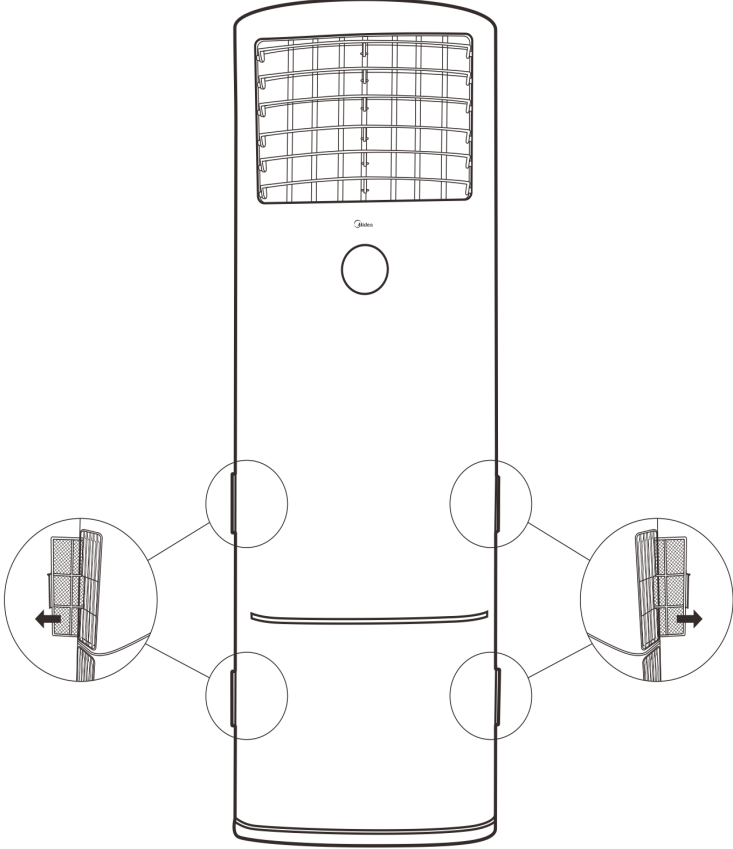
Procedure	Illustration
<p>1) Pull out the filters from each side of air inlet grille subassembly and air outlet grille subassembly (see CJ_GD_001)</p>	 <p>The illustration shows a front view of a vertical indoor unit. At the top is a large air inlet grille with a grid pattern. Below it is a small circular indicator light. The main body of the unit has a horizontal line indicating a split between the upper and lower sections. Four circular callouts are placed around the unit: two on the left side and two on the right side. Each callout shows a close-up of a filter being pulled out from a slot. Arrows indicate the direction of removal: leftward for the left-side filters and rightward for the right-side filters. Below the main diagram is the label 'CJ_GD_001'.</p>

Note: This section is for reference only. Actual unit appearance may vary.

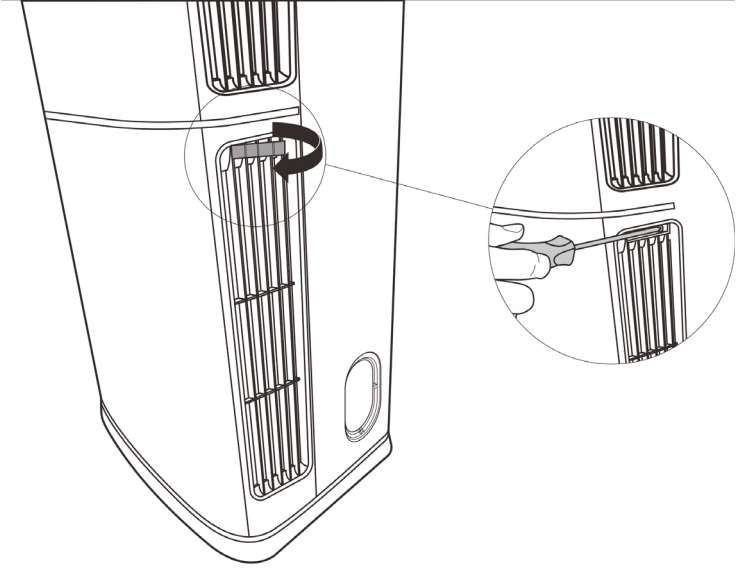
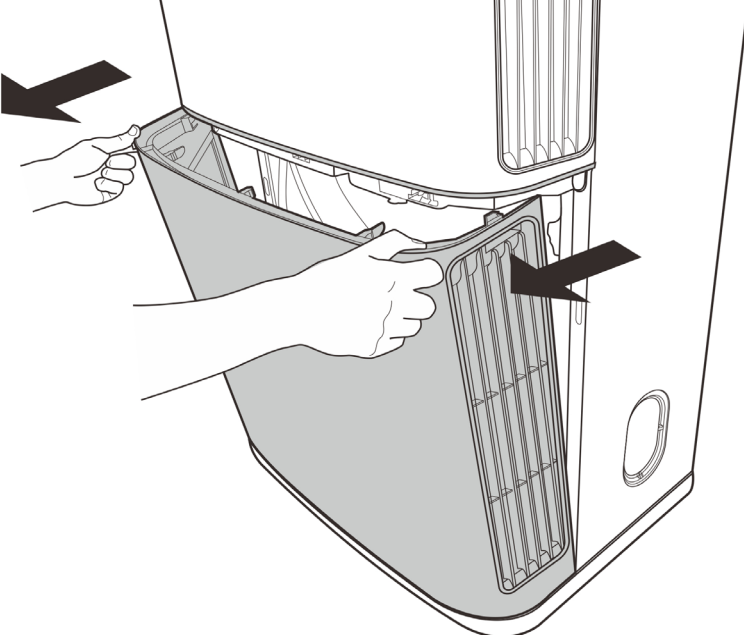

## 2.2 Air Inlet Grille Subassembly

Procedure	Illustration
<p>1) Open the screw cap on each side of air inlet grille subassembly.(see CJ_GD_002)</p> <p>2) Remove 2 screws. (see CJ_GD_002)</p> <p>3) Then pull the air inlet grille subassembly and lift up to remove it (see CJ_GD_003)</p> <p>(Note: To prevent injury, pay attention to the hooks located at the bottom.)</p>	 <p style="text-align: center;"><b>CJ_GD_002</b></p>  <p style="text-align: center;"><b>CJ_GD_003</b></p>

**Note:** This section is for reference only. Actual unit appearance may vary.

## 2.3 Air Outlet Frame Subassembly

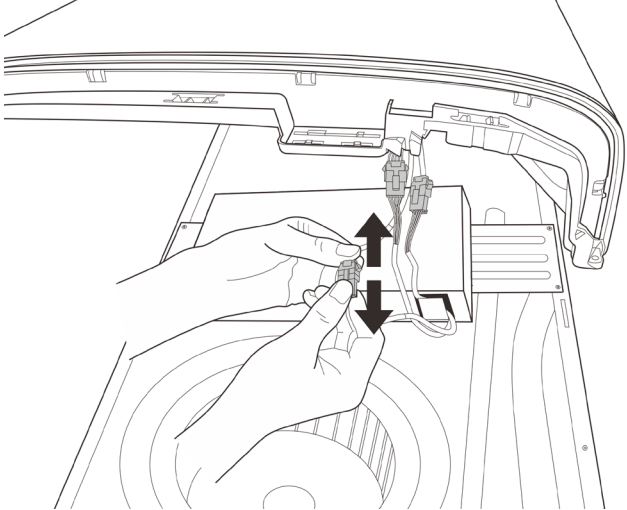
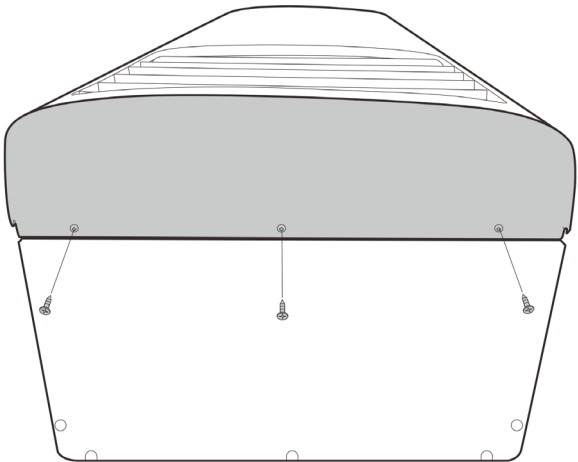
Procedure	Illustration
<p>1) Unplug the 3 connections.(see CJ_GD_004)</p>	 <p>CJ_GD_004</p>
<p>2) Remove 3 screws located on the top of air outlet frame subassembly. (see CJ_GD_005)</p>	 <p>CJ_GD_005</p>

**Note:** This section is for reference only. Actual unit appearance may vary.

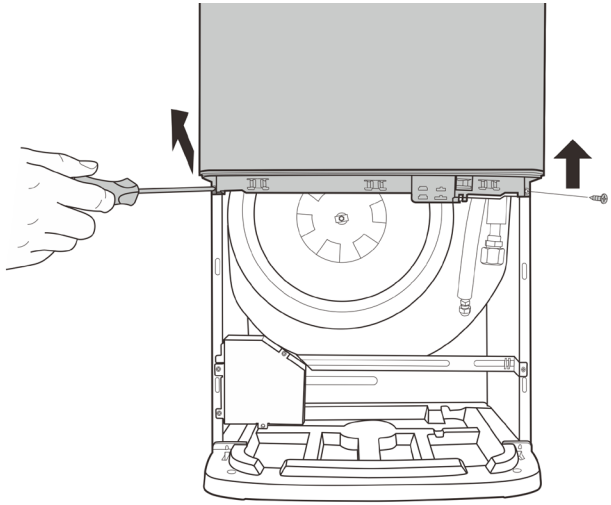
Procedure	Illustration
<p>3) Remove 2 screws located on the bottom left and right of air outlet frame subassembly. (see CJ_GD_006)</p> <p>4) Lift the air outlet frame subassembly up and pull it up to turn it over. (see CJ_GD_006)</p>	 <p>The diagram illustrates the process of removing the air outlet frame subassembly. A hand is shown using a screwdriver to remove a screw from the bottom left corner of the subassembly. Another screw is shown being removed from the bottom right corner. The subassembly is then lifted upwards, as indicated by an upward-pointing arrow, and pulled back to turn it over. The internal components of the unit, including the fan and the base, are visible.</p> <p style="text-align: center;"><b>CJ_GD_006</b></p>

**Note:** This section is for reference only. Actual unit appearance may vary.

## 2.4 Display Board

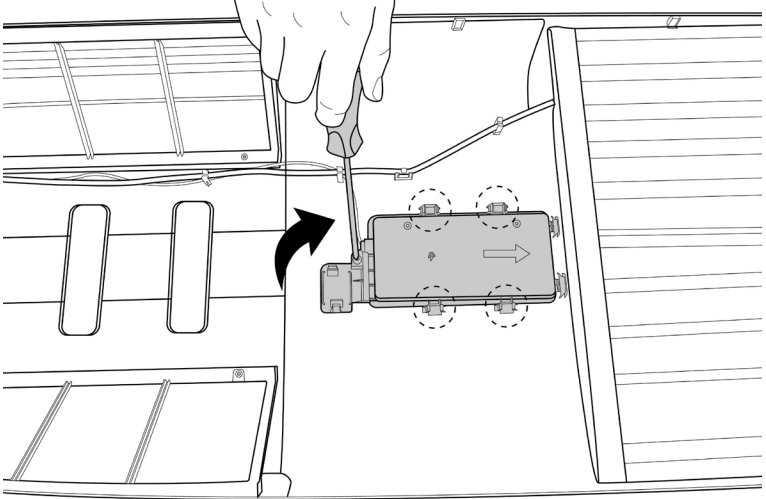
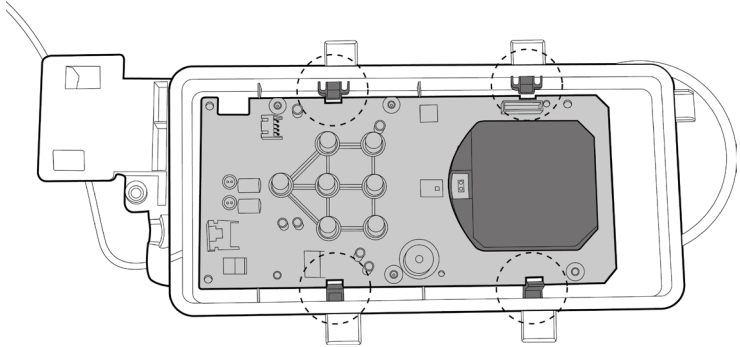
Procedure	Illustration
<p>1) Remove 1 screw. (see CJ_GD_007)</p> <p>2) Release 4 hooks. (see CJ_GD_007)</p> <p>3) Take out display control box subassembly and turn it over.(see CJ_GD_007)</p>	 <p style="text-align: center;"><b>CJ_GD_007</b></p>
<p>4) Release 4 hooks and take out the display board. (see CJ_GD_008)</p>	 <p style="text-align: center;"><b>CJ_GD_008</b></p>

**Note:** This section is for reference only. Actual unit appearance may vary.

## 2.5 Step Motor

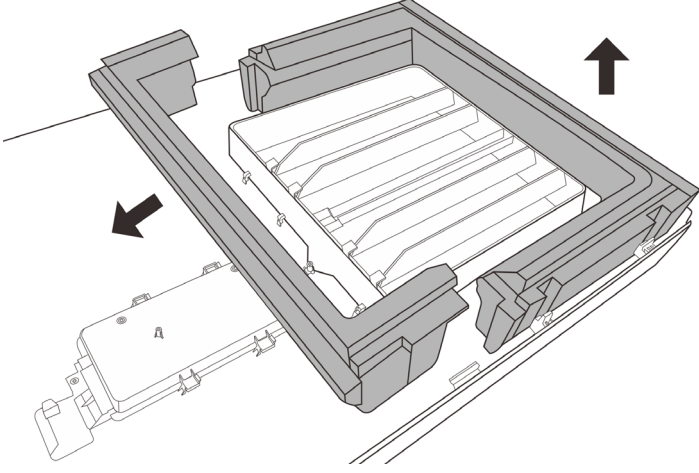
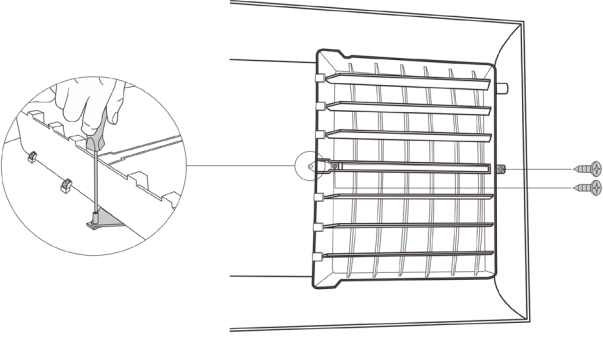
Procedure	Illustration
<p>1) Remove top air outlet foam and bottom air outlet foam . (see CJ_GD_009)</p>	 <p>CJ_GD_009</p>
<p>2) Remove 2 screws. (see CJ_GD_010)</p>	 <p>CJ_GD_010</p>

Note: This section is for reference only. Actual unit appearance may vary.

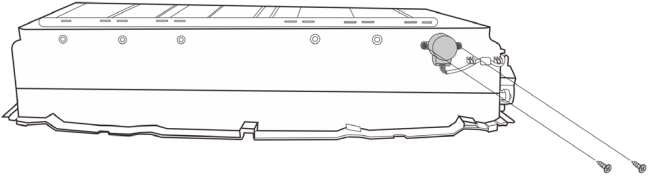
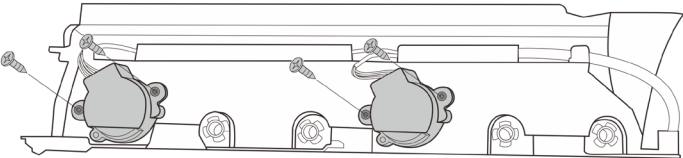
Procedure	Illustration
<p>3) Take out inner frame subassembly with 3 swing motors(one is vertical swing motor, two are horizontal swing motors).</p> <p>4) Remove 2 screws to remove the swing motor. (see CJ_GD_011&amp;012)</p>	 <p style="text-align: center;"><b>CJ_GD_011</b></p>  <p style="text-align: center;"><b>CJ_GD_012</b></p>

**Note:** This section is for reference only. Actual unit appearance may vary.

## 2.6 Electrical parts (Antistatic gloves must be worn.)

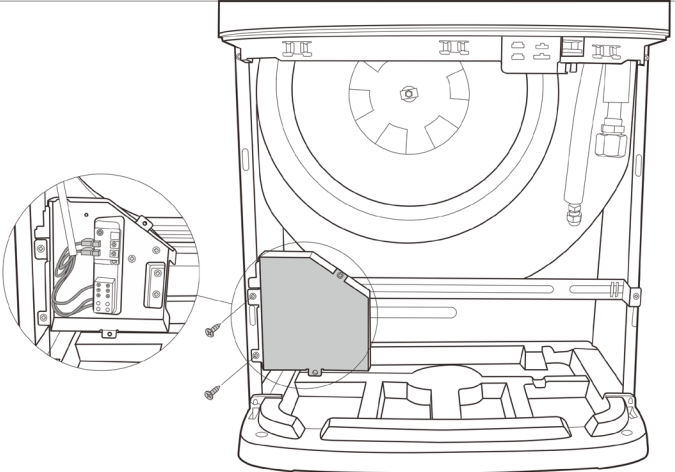
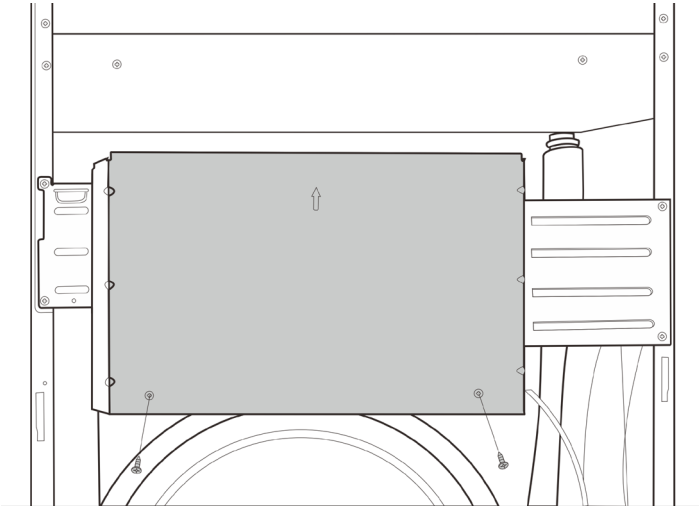
Procedure	Illustration
<p>1) Remove 2 screws of the cover of electrical connector.(see CJ_GD_013)</p>	 <p style="text-align: center;"><b>CJ_GD_013</b></p>
<p>2) Remove 2 screws of the cover of the electronic control box (see CJ_GD_014)</p> <p>3) Then remove the cover.</p>	 <p style="text-align: center;"><b>CJ_GD_014</b></p>

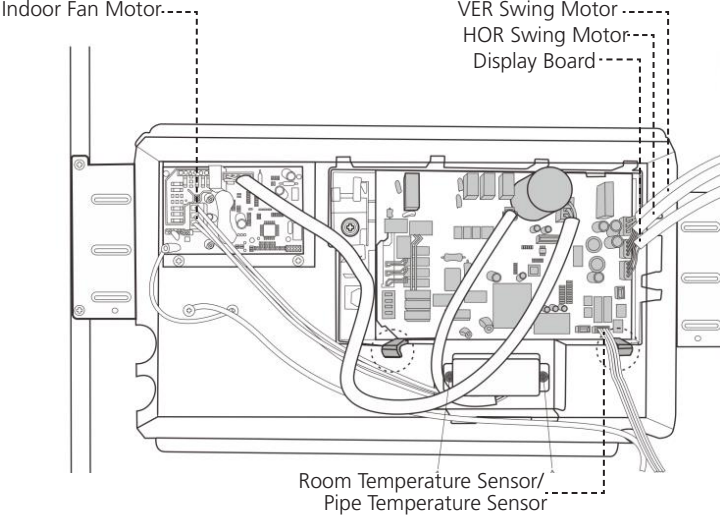
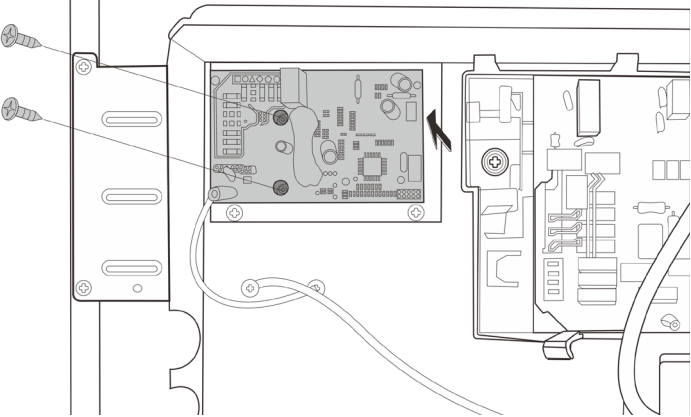
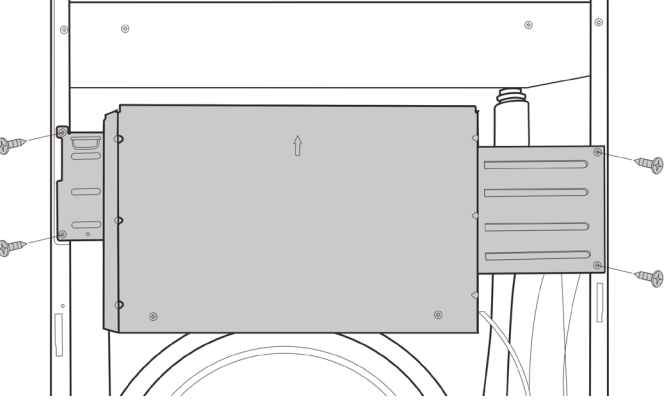

**Note:** This section is for reference only. Actual unit appearance may vary.

Procedure	Illustration
<p>4) Unplug all the connections on the main PCB. (see CJ_GD_015)</p> <p>5) Release 2 hooks and take out the main PCB (see CJ_GD_015)</p> <p>6) Release 2 screws then take out the reactor. (see CJ_GD_015)</p>	 <p style="text-align: center;"><b>CJ_GD_015</b></p>
<p>7) Release 2 screws then take out the inverter control board subassembly. (see CJ_GD_016)</p>	 <p style="text-align: center;"><b>CJ_GD_016</b></p>
<p>8) Release 4 screws affixing the electrical control box and remove it. (see CJ_GD_017)</p>	 <p style="text-align: center;"><b>CJ_GD_017</b></p>

**Note:** This section is for reference only. Actual unit appearance may vary.

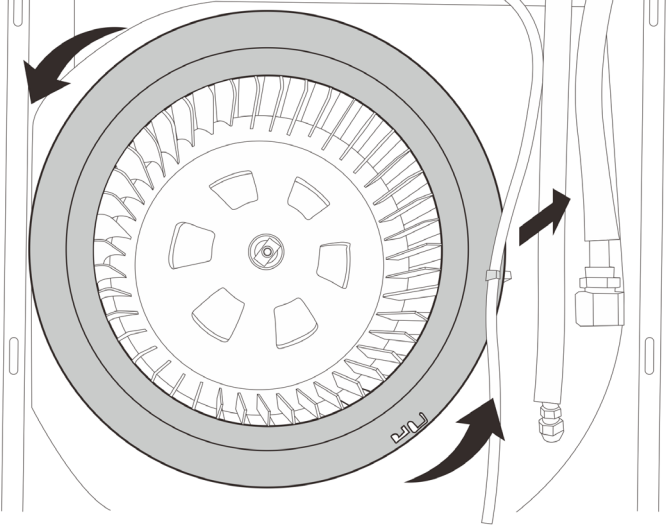

## 2.7 Fan Motor

Procedure	Illustration
<p>1) Rotate the ventilation ring counter-clockwise and until the 4 clips pop out of their holes. (see CJ_GD_018)</p> <p>2) Pull out the ventilation ring. (see CJ_GD_018)</p>	 <p>The diagram shows a top-down view of a circular ventilation ring with a fan wheel inside. The ring is mounted in a rectangular frame. Four black arrows point counter-clockwise from the top of the ring, indicating the direction of rotation. A single black arrow points to the right from the right side of the ring, indicating the direction of removal. The fan wheel has five blades and a central hub.</p> <p style="text-align: center;"><b>CJ_GD_018</b></p>
<p>3) Remove the affixing nut on the axis of the fan wheel. (see CJ_GD_019)</p>	 <p>The diagram shows a close-up of a hand using a screwdriver to remove a nut from the axis of the fan wheel. The fan wheel is partially visible, and the hand is positioned to turn the nut. A black arrow points to the right from the nut, indicating the direction of removal. The background shows the internal components of the unit.</p> <p style="text-align: center;"><b>CJ_GD_019</b></p>

**Note:** This section is for reference only. Actual unit appearance may vary.

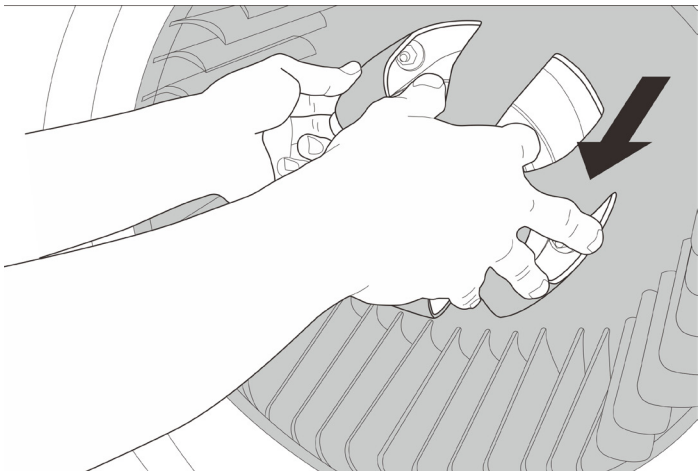
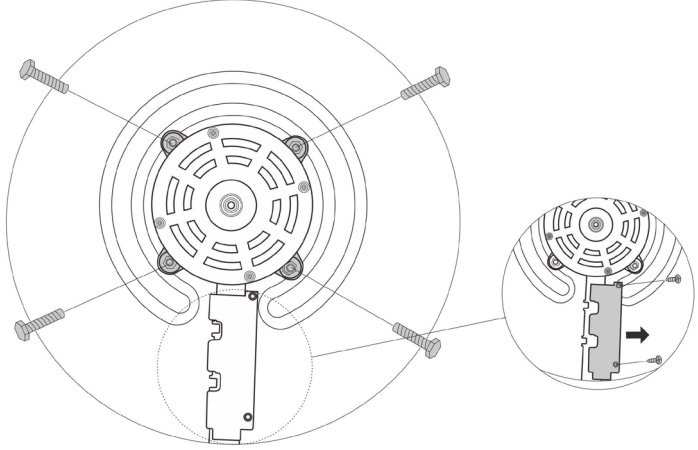
Procedure	Illustration
<p>4) Take the fan wheel out(see CJ_GD_020)</p>	 <p style="text-align: center;"><b>CJ_GD_020</b></p>
<p>5) Remove 4 nuts around of the motor and 2 screws affixing the cover for the wires. (see CJ_GD_021)</p> <p>6) Remove the fan motor.</p>	 <p style="text-align: center;"><b>CJ_GD_021</b></p>

**Note:** This section is for reference only. Actual unit appearance may vary.

## 2.8 Evaporator

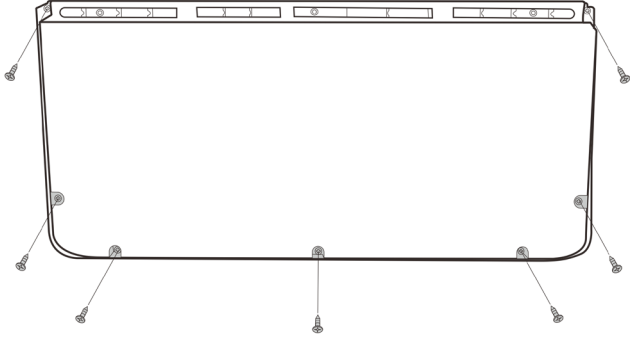
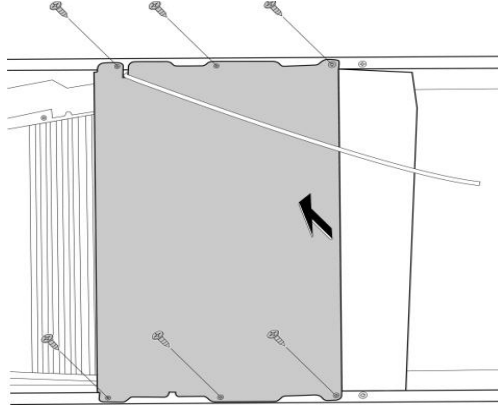
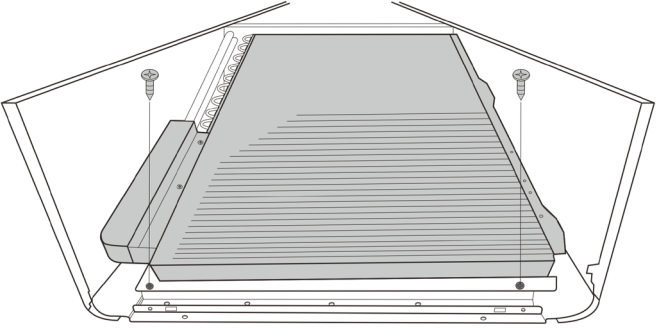
Procedure	Illustration
<p>1) Remove 7 screws affixing the top cover.(see CJ_GD_022)</p> <p>2) Remove the top cover.</p>	 <p style="text-align: center;"><b>CJ_GD_022</b></p>
<p>3) Remove 3 screws on each side of the cover assembly.(see CJ_GD_023)</p> <p>4) Take the cover off.</p>	 <p style="text-align: center;"><b>CJ_GD_023</b></p>
<p>5) Remove 2 screws affixing the inlet/outlet pipes of the evaporator.(see CJ_GD_024)</p>	 <p style="text-align: center;"><b>CJ_GD_024</b></p>

**Note:** This section is for reference only. Actual unit appearance may vary.

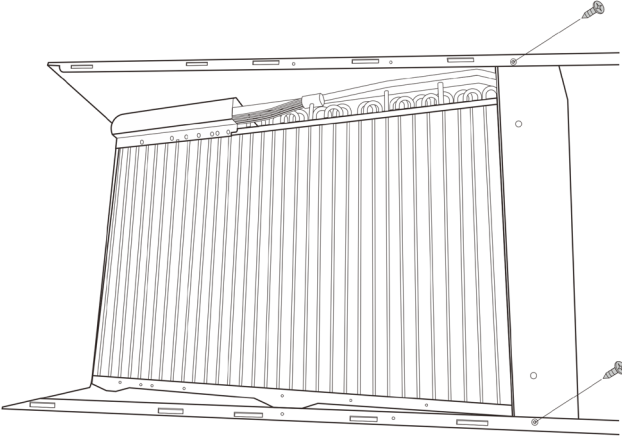
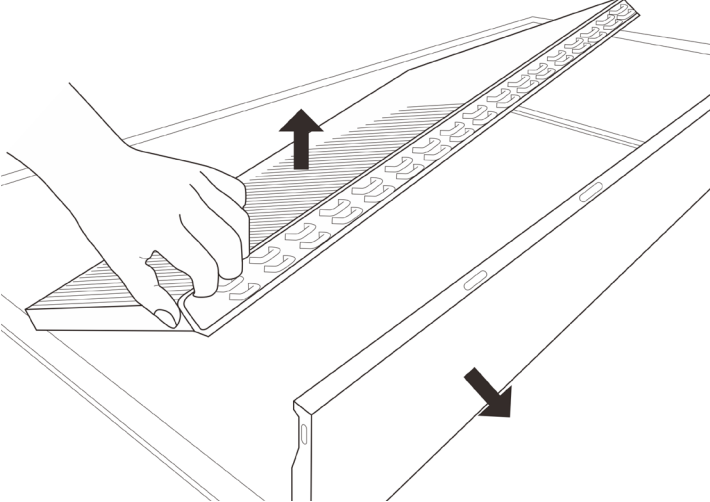
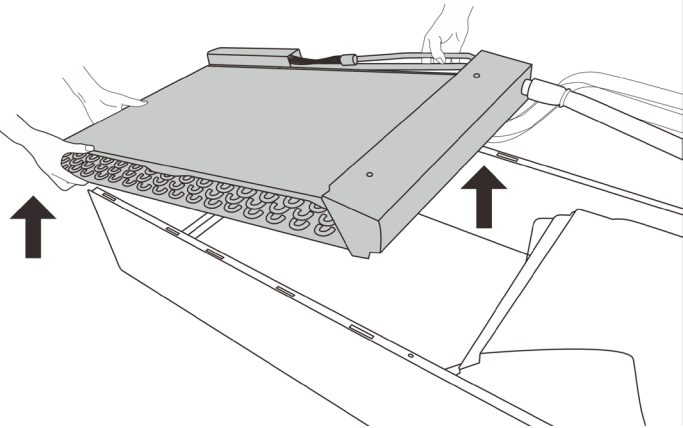
Procedure	Illustration
<p>6) Remove 2 screws affixing the water collector subassembly.(see CJ_GD_025)</p>	 <p style="text-align: center;"><b>CJ_GD_025</b></p>
<p>7) Push the side panel slightly so that you can lift the evaporator.(see CJ_GD_026)</p>	 <p style="text-align: center;"><b>CJ_GD_026</b></p>
<p>8) Remove the evaporator.(see CJ_GD_027)</p>	 <p style="text-align: center;"><b>CJ_GD_027</b></p>

**Note:** This section is for reference only. Actual unit appearance may vary.

---

# Outdoor Unit Disassembly

## Contents

<b>1.</b>	<b>Outdoor Unit Table</b> .....	<b>2</b>
<b>2.</b>	<b>Dimension</b> .....	<b>3</b>
<b>3.</b>	<b>Outdoor Unit Disassembly</b> .....	<b>4</b>
3.1	Panel Plate.....	4
3.2	Electrical Parts .....	7
3.3	Fan Assembly .....	9
3.4	Fan Motor .....	10
3.5	Sound blanket.....	11
3.6	Four-way valve.....	12
3.7	Compressor .....	13

---

## 1. Outdoor Unit Disassembly

### 1.1 Outdoor Unit Table

Outdoor Unit Model	Panel Plate	PCB Board
V6FO-60	E30	PCB Board 4

---

## 2. Dimension

### Panel Plate E30

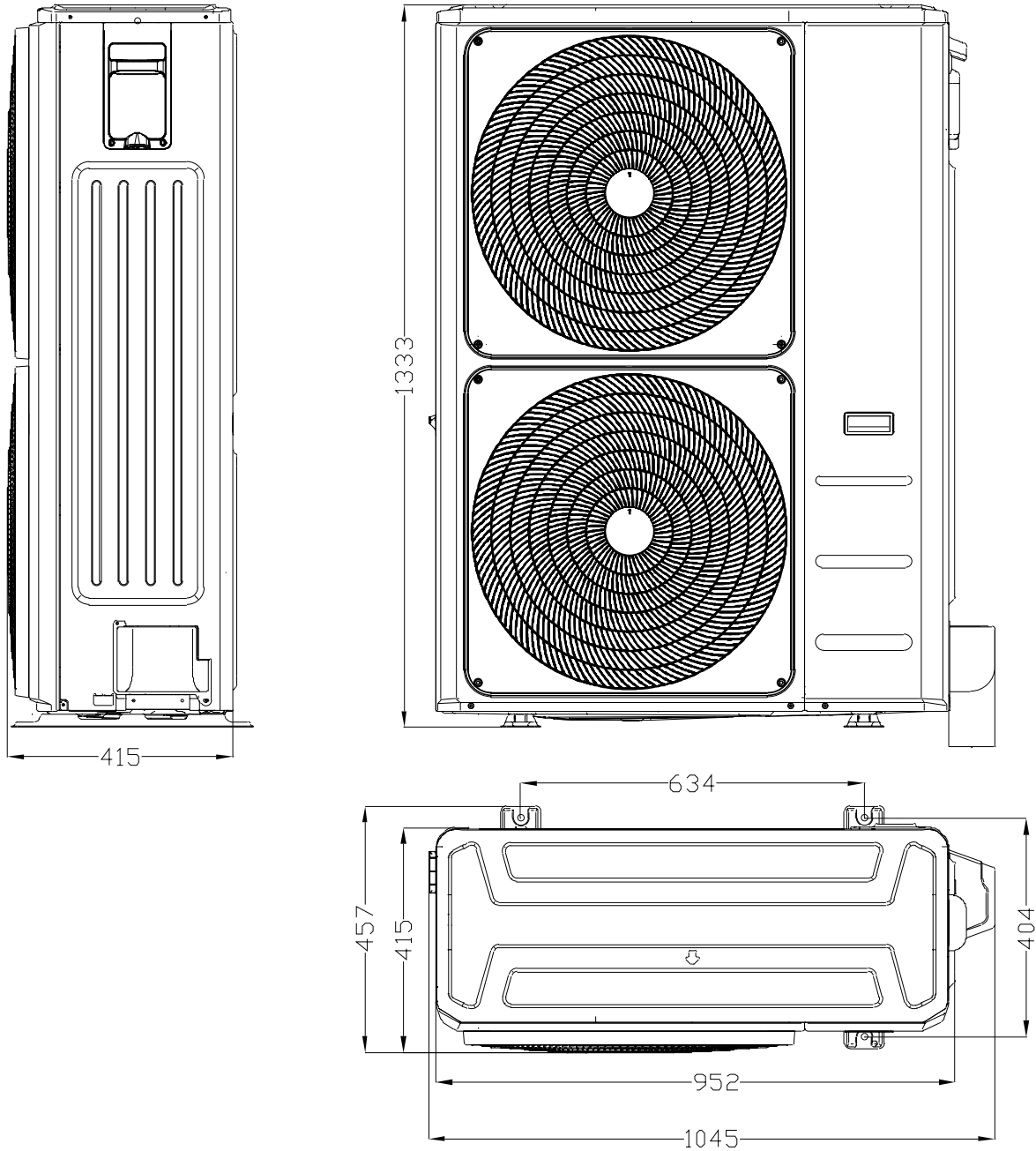

### 3. Outdoor Unit Disassembly

#### 3.1 Panel Plate

E30

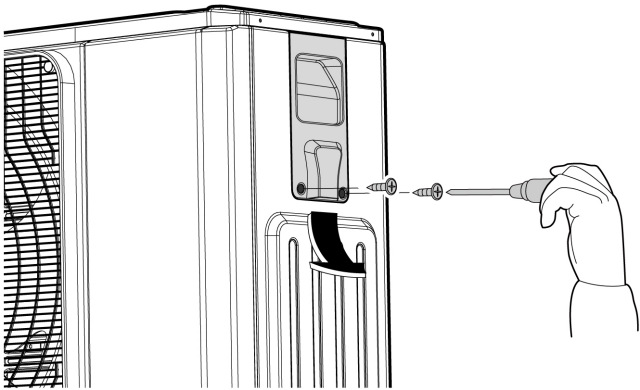
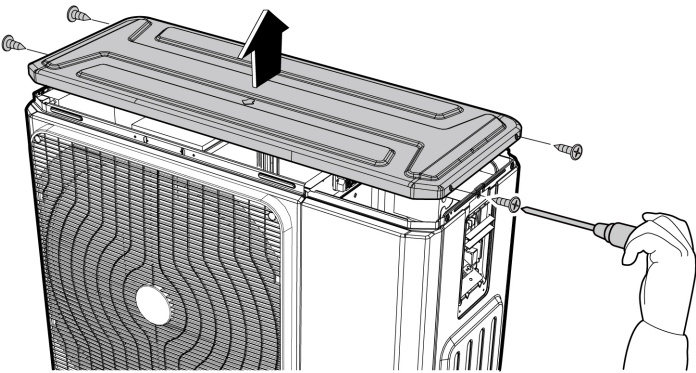
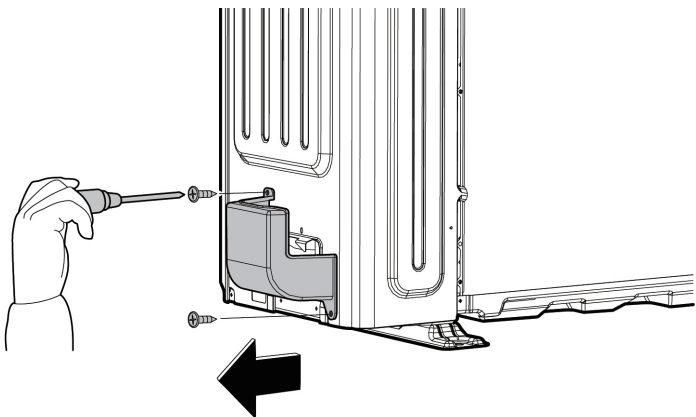
Procedure	Illustration
<p>1) Turn off the air conditioner and the power breaker.</p> <p>2) Remove the screws of the big handle and then remove the big handle (2 screws) (see CJ_E30_001).</p>	 <p>CJ_E30_001</p>
<p>3) Remove the screws of the top cover and then remove the top cover (4 screws). Two of the screws is located underneath the big handle (see CJ_E30_002).</p>	 <p>CJ_E30_002</p>
<p>4) Remove the screws of water collecting cover and then remove the water collecting cover (2 screw) (see CJ_E30_003).</p>	 <p>CJ_E30_003</p>

Note: This section is for reference only. Actual unit appearance may vary.

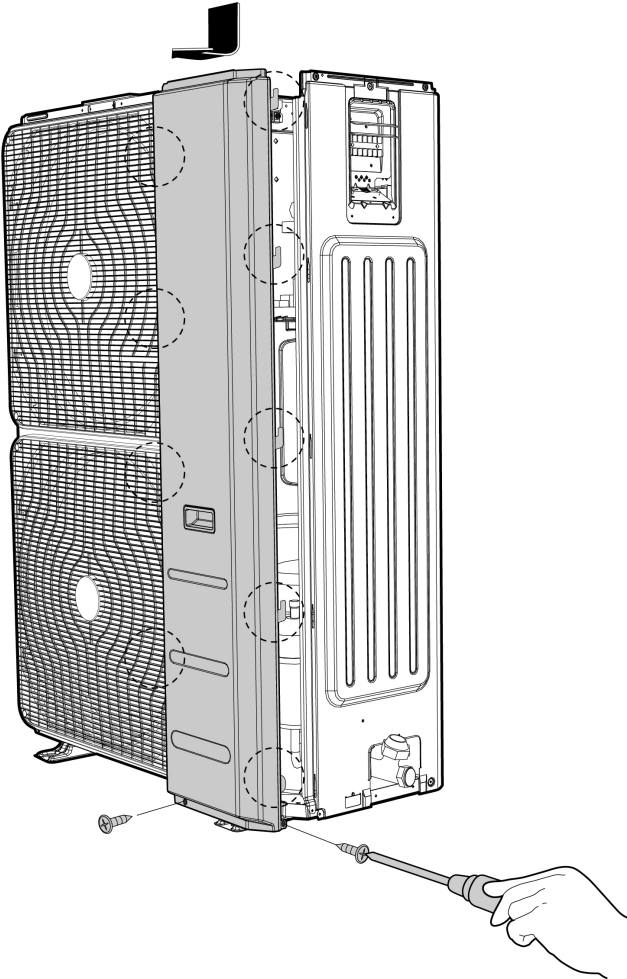

Procedure	Illustration
<p>5) Remove the screws of the front right panel and then remove the front right panel (2 screws) (see CJ_E30_004).</p>	 <p>CJ_E30_004</p>

Note: This section is for reference only. Actual unit appearance may vary.

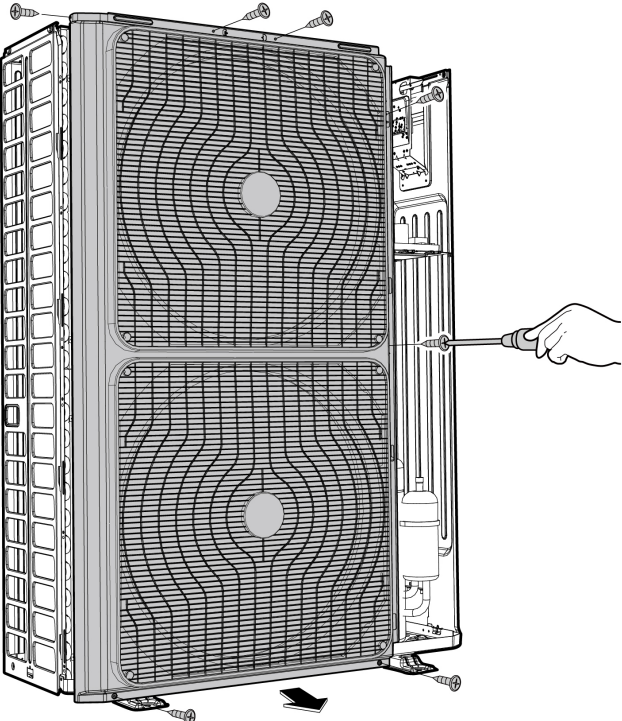
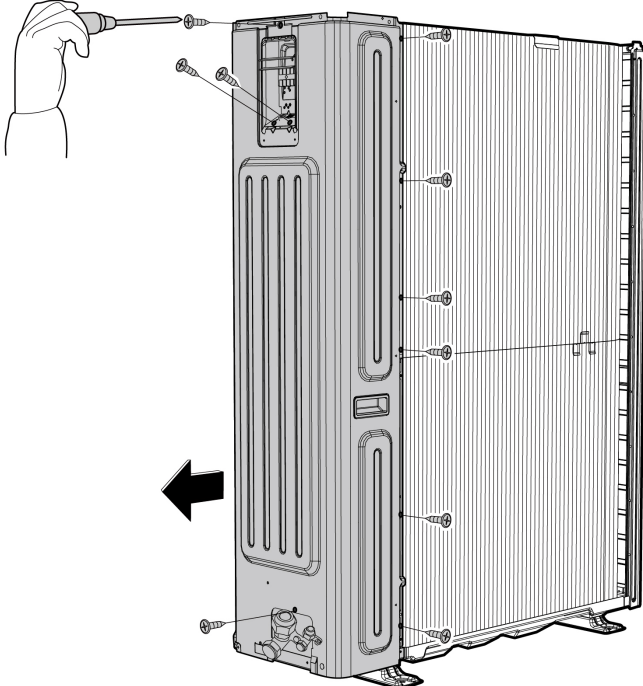
Procedure	Illustration
<p>1) Remove the screws of the front panel and then remove the front panel (7 screws) (see CJ_E30_005).</p>	 <p style="text-align: center;"><b>CJ_E30_005</b></p>
<p>2) Remove the screws of the right panel and then remove the right panel (10 screws) (see CJ_E30_006).</p>	 <p style="text-align: center;"><b>CJ_E30_006</b></p>

**Note:** This section is for reference only. Actual unit appearance may vary.

---

## 3.2 Electrical parts

 **WARNING:** Antistatic gloves must be worn when you disassemble the electronic box.

**Note:** Remove the air outlet grille(refer to 3.1 Panel Plate) before disassembling electrical parts.

D76 Zcf -bj YfhYf A cXYg

## PCB board 4

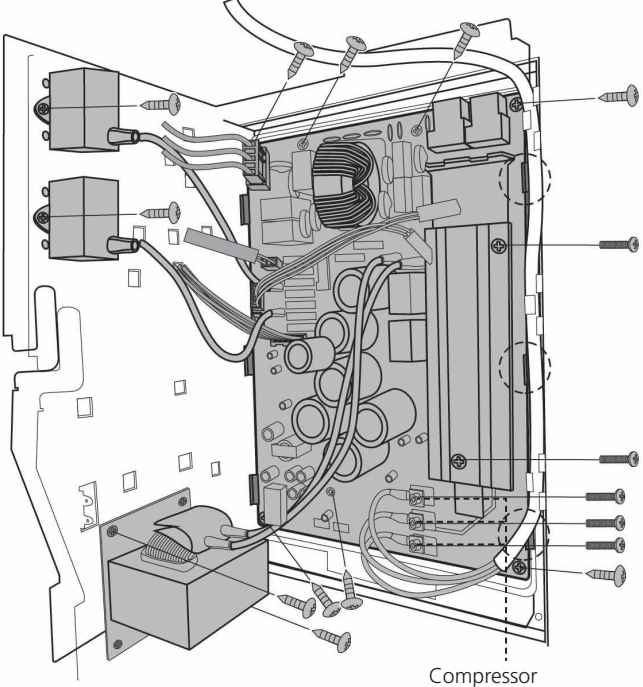
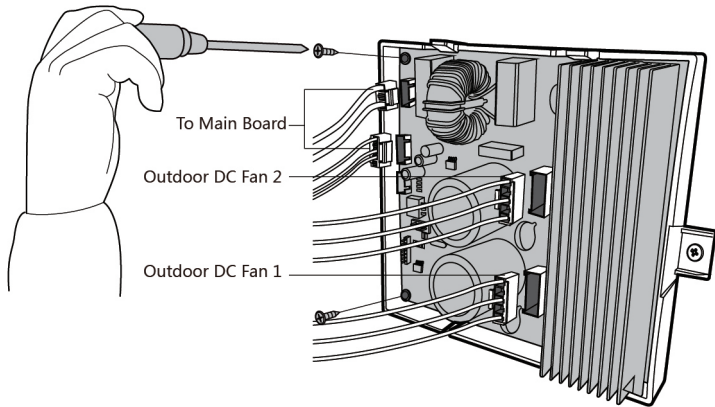
Procedure	Illustration
<ol style="list-style-type: none"><li>1) Remove 3 screws to disconnect the wires connected to the compressor. (see CJ_ODU_PCB_004-1)</li><li>2) Pull out the connectors (see CJ_ODU_PCB_004-1)</li><li>3) Remove 2 screws to remove the radiator. (see CJ_ODU_PCB_004-1)</li><li>4) Remove the 7 screws and unfix the 3 hooks and then remove the main control board. (see CJ_ODU_PCB_004-1)</li><li>5) Remove 2 screws to remove the reactor. (see CJ_ODU_PCB_004-1).</li><li>6) Remove 1 screw to remove the fan motor capacitor (1 screw for each capacitor). (see CJ_ODU_PCB_004-1).</li></ol>	 <p data-bbox="1109 1097 1220 1120">Compressor</p> <p data-bbox="877 1153 1133 1187"><b>CJ_ODU_PCB_004-1</b></p>
<ol style="list-style-type: none"><li>7) Disconnect the wires connected to main control board. (see CJ_ODU_PCB_004-2) (for some models)</li><li>8) Remove the 2 screws and then remove the DC motor driver board. (see CJ_ODU_PCB_004-2) (for some models)</li></ol>	 <p data-bbox="821 1377 949 1400">To Main Board</p> <p data-bbox="790 1433 949 1456">Outdoor DC Fan 2</p> <p data-bbox="790 1534 949 1556">Outdoor DC Fan 1</p> <p data-bbox="877 1713 1133 1780"><b>CJ_ODU_PCB_004-2</b> (for some models)</p>

**Note:** This section is for reference only. Actual unit appearance may vary.

### 3.3 Fan Assembly

**Note:** Remove the panel plate (refer to 3.1 Panel Plate) before disassembling fan.

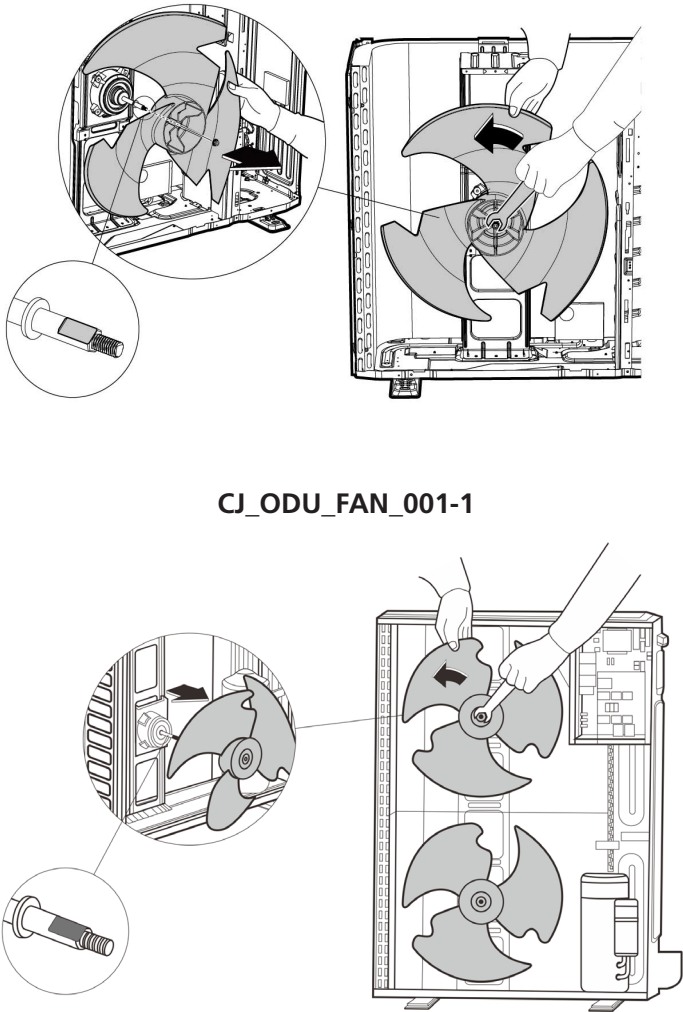
Procedure	Illustration
<p>1) Remove the nut securing the fan with a spanner (see CJ_ODU_FAN_001-1&amp;2).</p> <p>2) Remove the fan.</p>	 <p data-bbox="874 1003 1136 1030">CJ_ODU_FAN_001-1</p> <p data-bbox="874 1572 1136 1599">CJ_ODU_FAN_001-2</p>

**Note:** This section is for reference only. Actual unit appearance may vary.

### 3.4 Fan Motor

**Note:** Remove the panel plate and the connection of fan motor on PCB (refer to 3.1 Panel Plate and 3.2 Electrical parts) before disassembling fan motor.

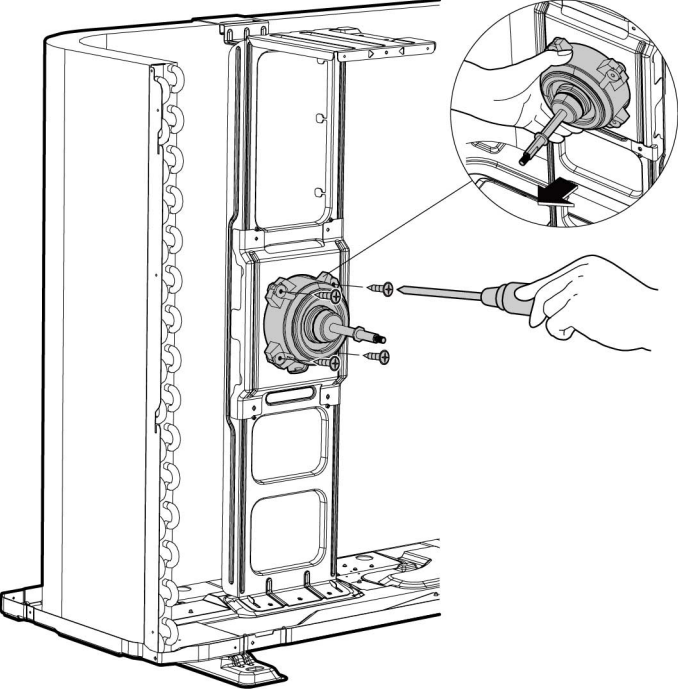
Procedure	Illustration
<p>3) Remove the fixing screws of the fan motor (4 screws) (see CJ_ODU_MOTOR_001).</p> <p>4) Remove the fan motor.</p>	 <p>The illustration shows a side view of an outdoor unit with the fan motor assembly highlighted. A hand is shown using a screwdriver to remove one of the four screws that secure the fan motor to the unit's frame. A circular inset provides a magnified view of the fan motor being held in place by the screws. The label 'CJ_ODU_MOTOR_001' is positioned below the main illustration.</p> <p data-bbox="898 1234 1182 1267">CJ_ODU_MOTOR_001</p>

**Note:** This section is for reference only. Actual unit appearance may vary.

### 3.5 Sound blanket

Note: Remove the panel plate (refer to 3.1 Panel plate) before disassembling sound blanket.

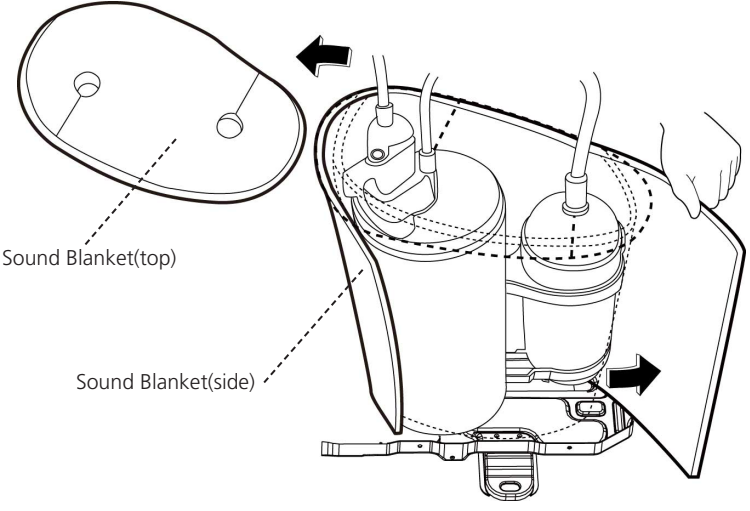
Procedure	Illustration
1) Remove the sound blanket (side and top) (see CJ_ODU_BLANKET_001).	 <p data-bbox="863 974 1166 1003">CJ_ODU_BLANKET_001</p>

Note: This section is for reference only. Actual unit appearance may vary.

### 3.6 Four-way valve (for heat pump models)

**⚠ WARNING:** Evacuate the system and confirm that there is no refrigerant left in the system before removing the four-way valve and the compressor. (For R32 & R290, you should evacuate the system with the vacuum pump; flush the system with nitrogen; then repeat the two steps before heating up the brazed parts. The operations above should be implemented by professionals.)

**Note:** Remove the panel plate, connection of four-way valve on PCB (refer to 3.1 Panel plate and 3.2 Electrical parts) before disassembling sound blanket.

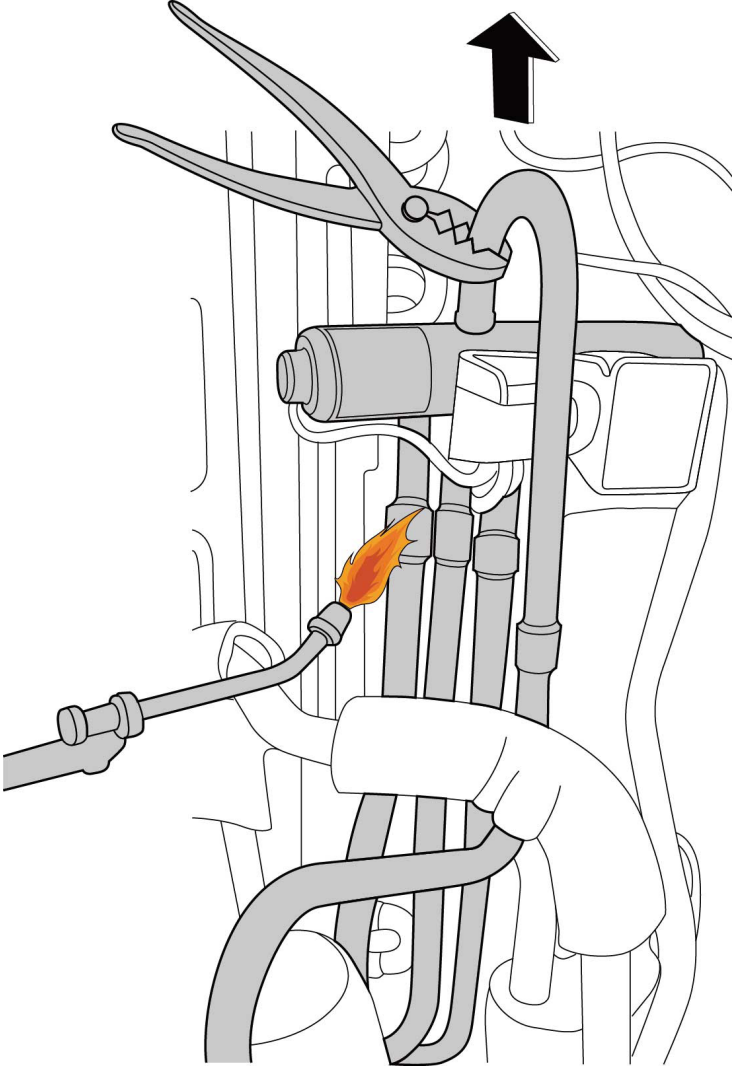
Procedure	Illustration
<ol style="list-style-type: none"><li>1) Heat up the brazed parts and then detach the the four-way valve and the pipe (see CJ_ODU_VALVE_001).</li><li>2) Remove the four-way valve assembly with pliers.</li></ol>	 <p data-bbox="911 1693 1171 1727">CJ_ODU_VALVE_001</p>

**Note:** This section is for reference only. Actual unit appearance may vary.



### 3.7 Compressor

**⚠ WARNING:** Evacuate the system and confirm that there is no refrigerant left in the system before removing the four-way valve and the compressor. (For R32 & R290, you should evacuate the system with the vacuum pump; flush the system with nitrogen; then repeat the two steps before heating up the brazed parts. The operations above should be implemented by professionals.)

**Note:** Remove the panel plate, connection of compressor on PCB (refer to 3.1 Panel plate and 3.2 Electrical parts) before disassembling sound blanket.

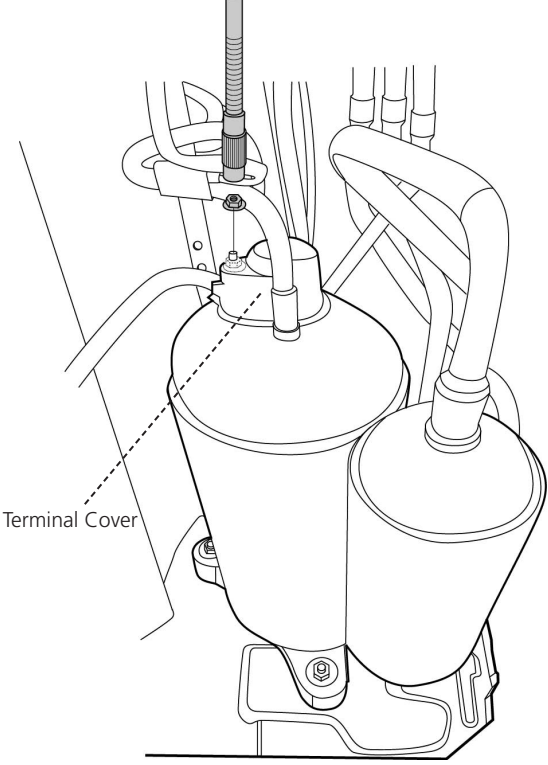
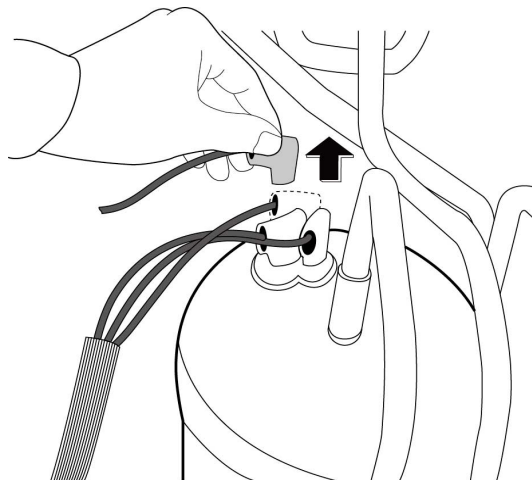
Procedure	Illustration
1) Remove the flange nut of terminal cover and remove the terminal cover (see CJ_ODU_COMP_001).	 <p>The diagram shows a top-down view of the compressor assembly. A dashed line points to a terminal cover on the left side of the unit. The cover is being lifted away from the compressor's terminal block.</p> <p style="text-align: center;"><b>CJ_ODU_COMP_001</b></p>
2) Disconnect the connectors (see CJ_ODU_COMP_002).	 <p>The diagram shows a close-up of a hand pulling a connector away from the terminal block. An upward-pointing arrow indicates the direction of removal. The terminal block is part of the compressor assembly.</p> <p style="text-align: center;"><b>CJ_ODU_COMP_002</b></p>

**Note:** This section is for reference only. Actual unit appearance may vary.

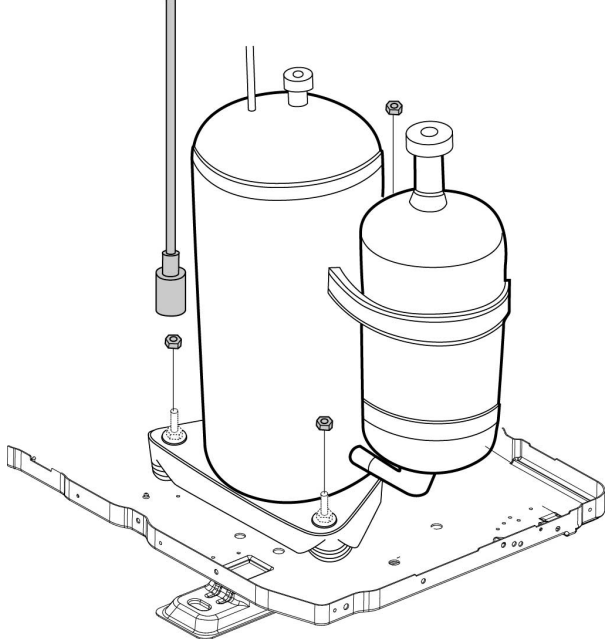
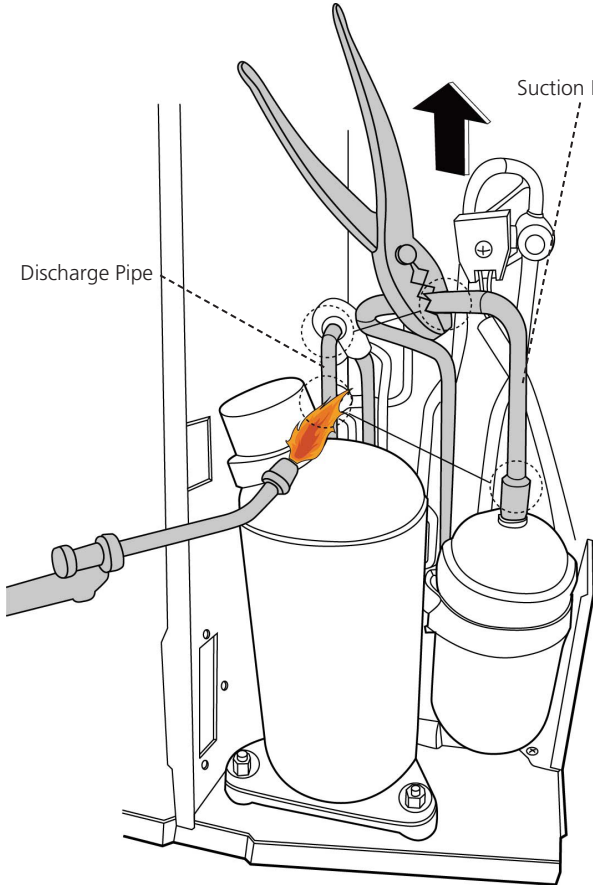
Procedure	Illustration
<p>3) Remove the hex nuts and washers securing the compressor, located on the bottom plate (see CJ_ODU_COMP_003).</p>	 <p style="text-align: center;"><b>CJ_ODU_COMP_003</b></p>
<p>4) Heat up the brazed parts and then remove the the discharge pipe and the suction pipe (see CJ_ODU_COMP_004).</p> <p>5) Lift the compressor from the base pan assembly with pliers.</p>	 <p style="text-align: center;"><b>CJ_ODU_COMP_004</b></p>

**Note:** This section is for reference only. Actual unit appearance may vary.

---

# Troubleshooting

## Contents

<b>1.</b>	<b>Safety Caution .....</b>	<b>3</b>
<b>2.</b>	<b>General Troubleshooting .....</b>	<b>4</b>
<b>3.</b>	<b>Complain Record Form .....</b>	<b>6</b>
<b>4.</b>	<b>Information Inquiry .....</b>	<b>8</b>
<b>5.</b>	<b>Error Diagnosis and Troubleshooting Without Error Code.....</b>	<b>11</b>
5.1	Remote maintenance.....	11
5.2	Field maintenance .....	12
<b>6.</b>	<b>Quick Maintenance by Error Code.....</b>	<b>17</b>
<b>7.</b>	<b>Troubleshooting by Error Code.....</b>	<b>18</b>
	TS01-IDU Indoor EEPROM Parameter Error Diagnosis and Solution	
	TS01-ODU Outdoor EEPROM Parameter Error Diagnosis and Solution	
	TS02-L-INV Indoor and Outdoor Unit Communication Error Diagnosis and Solution	
	TS04-L-IDU Indoor Fan Speed is Operating Outside of The Normal Range Diagnosis and Solution	
	TS04-L-ODU Outdoor Fan Speed is Operating Outside of The Normal Range Diagnosis and Solution	
	TS05-IDU .. Open Circuit or Short Circuit of Indoor Temperature Sensor Diagnosis and Solution	
	TS05-ODU Open Circuit or Short Circuit of Outdoor Temperature Sensor Diagnosis and Solution	
	TS05-L-ODU Open Circuit or Short Circuit of Outdoor Temperature Sensor or Outdoor Unit Eeprom Parameter Error Diagnosis and Solution	
	TS06-INV Refrigerant Leakage Detection Diagnosis and Solution	

---



# Contents

TS07 Indoor PCB/Display Board Communication Error Diagnosis and Solution

TS09-L IPM Malfunction or IGBT Over-strong Current Protection Diagnosis and Solution

TS10-L Over Voltage or Too Low Voltage Protection Diagnosis and Solution

TS11-L Top temperature Protection of Compressor Diagnosis and Solution

TS13-INV Low Pressure Protection Diagnosis and Solution

TS18 Outdoor Unit Malfunction Diagnosis and Solution

TS30 PFC Module Protection Diagnosis and Solution

TS33 Communication Error Between Outdoor Main Chip And Compressor Driven Chip  
Diagnosis and Solution(for some manuals)

TS37 Indoor And Outdoor Mismatch Malfunction Diagnosis and Solution

## **8. Check Procedures**

## 1. Safety Caution

### ⚠ WARNING

Be sure to turn off all power supplies or disconnect all wires to avoid electric shock. While checking indoor/outdoor PCB, please equip oneself with antistatic gloves or wrist strap to avoid damage to the board.

### ⚠ WARNING

Electricity remains in capacitors even when the power supply is off. Ensure the capacitors are fully discharged before troubleshooting.

Test the voltage between P and N on back of the main PCB with multimeter. If the voltage is lower than 36V, the capacitors are fully discharged.

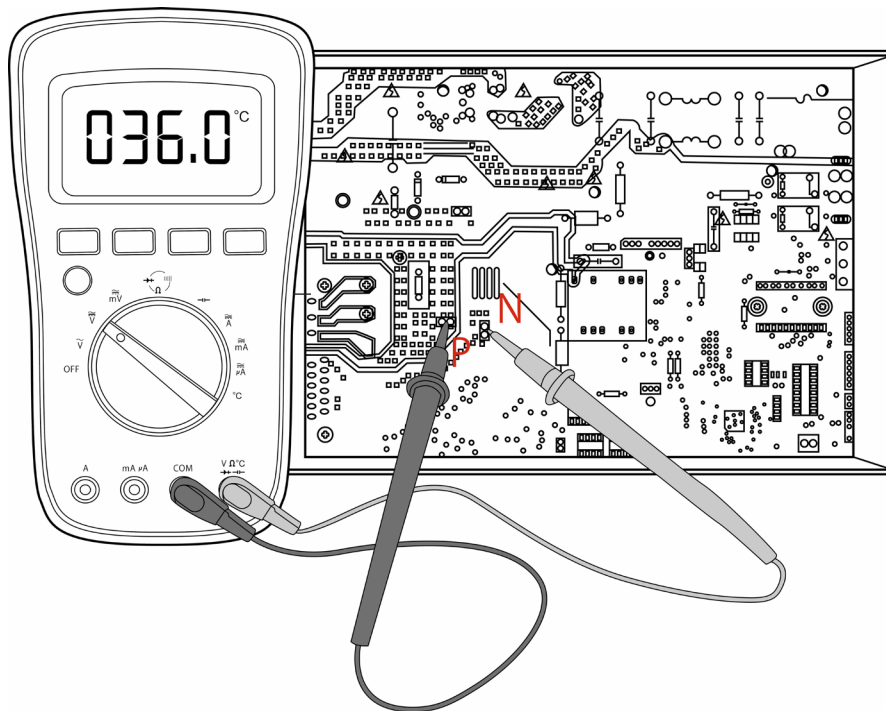

**Note:** This picture is for reference only. Actual appearance may vary.

---

## 2. General Troubleshooting

### 2.1 Error Display (Indoor Unit)

These error codes are described in the following tables:

Display	Error Information	Solution
dF	Defrost	--
SC	Self clean	--
FP	Heating in room temperature under 8°C	--
EH00/EH0A	Indoor unit EEPROM parameter error	TS01-IDU
EL01	Indoor/outdoor unit communication error	TS02-L-INV
EH03	The indoor fan speed is operating outside of the normal range	TS04-L-IDU
EE50	Outdoor temperature sensor is in open circuit or has short circuited	TS05-ODU
EE51	Outdoor unit EEPROM parameter error	TS01-ODU
EE52	Condenser coil temperature sensor T3 is in open circuit or has short circuited	TS05-ODU
EE53	Outdoor room temperature sensor T4 is in open circuit or has short circuited	TS05-ODU
EE54	Compressor discharge temperature sensor TP is in open circuit or has short circuited	TS05-ODU
EE55	IGBT temperature sensor TH is in open circuit or has short circuited	TS05-ODU
EE56	Evaporator coil outlet temperature sensor T2B is in open circuit or has short circuited(for free-match outdoor units)	TS05-ODU
EE05	Open circuit or short circuit of outdoor temperature sensor or outdoor unit EEPROM parameter error	TS05-L-ODU
EH60	Indoor room temperature sensor T1 is in open circuit or has short circuited	TS05-IDU
EH61	Evaporator coil middle temperature sensor T2 is in open circuit or has short circuited	TS05-IDU
EE07	The outdoor fan speed is operating outside of the normal range	TS04-ODU
EH0b	Indoor PCB/Display board communication error	TS07
EL0c	Refrigerant leakage detection	TS06-INV

PC00	IPM malfunction or IGBT over-strong current protection	TS09-L
PC01	Over voltage or over low voltage protection	TS10-L
PC02	Top temperature protection of compressor	TS11-L
PC04	Inverter compressor drive error	TS09-L
PC0F	PFC module protection	TS30
PC40	Communication error between outdoor main chip and compressor driven chip	TS33
PC03	High pressure protection or low pressure protection	TS13-INV/TS28
EC0d	Outdoor unit malfunction	TS18
FL09	Indoor and outdoor mismatch malfunction	TS37

**For other errors:**

The display board may show a garbled code or a code undefined by the service manual. Ensure that this code is not a temperature reading.

**Troubleshooting:**

Test the unit using the remote control. If the unit does not respond to the remote, the indoor PCB requires replacement. If the unit responds, the display board requires replacement.

**88 flash frequency:**

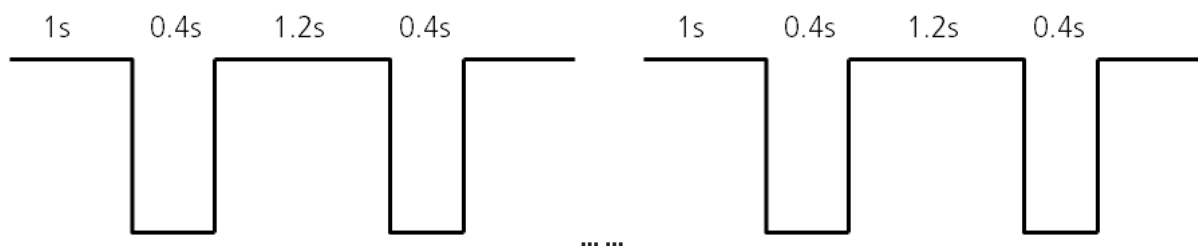

## Information Inquiry

- To enter information inquiry status, complete the following procedure within 10 seconds:
  - Press LED 3 times.
  - Press SWING 3 times.
- Finish 1 and 2 within 10 seconds, you will hear beeps for two seconds, which means the unit goes into parameter checking mode.
- Use the LED(or DO NOT DISTURB) and SWING(or AIR DIRECTION) buttons to cycle through information displayed.
- Pressing LED(or DO NOT DISTURB) displays the next code in the sequence. Pressing SWING(or AIR DIRECTION) will show the previous.
- The following table shows information codes. The screen displays this code for 1.2 seconds, then the information for 25 seconds.

Displayed code	Explanation	Additional Notes
Error code		Refer to next list of error code
T1	T1	T1 temperature
T2	T2	T2 temperature
T3	T3	T3 temperature
T4	T4	T4 temperature
TP	TP	TP temperature
Targeted frequency	FT	Targeted Frequency
Actual frequency	Fr	Actual Frequency
Compressor current	dL	N/A
Outdoor AC voltage	Uo	N/A
Indoor capacity test	Sn	N/A
Reserve	--	N/A
Outdoor fan speed	Pr	Outdoor fan speed=value*8
EXV opening angle	Lr	EXV opening angle-value*8
Indoor fan speed	ir	Indoor fan speed=value*8
Indoor humidity	HU	N/A
Adjusted setting temperature	TT	N/A
Reserve	--	N/A
Reserve	--	N/A
Reserve	--	N/A
GA algorithm frequency	oT	N/A



Error code

Display	Error Information
Eh00/Eh0A	Indoor unit EEPROM parameter error
EL01	Indoor / outdoor unit communication error
Eh31	Over low voltage protection of indoor external fan
Eh32	Over voltage protection of indoor external fan
Eh33	Over-current protection of indoor external fan
Eh34	Indoor external fan driver module protection
Eh35	Phase failure of indoor external fan
Eh36	Indoor external fan current sampling bias fault
Eh37	Zero speed failure of indoor external fan
Eh03	The indoor fan speed is operating outside of the normal range
EC50	Outdoor temperature sensor is in open circuit or has short circuited
EC51	Outdoor unit EEPROM parameter error
EC52	Condenser coil temperature sensor T3 is in open circuit or has short circuited
EC53	Outdoor room temperature sensor T4 is in open circuit or has short circuited
EC54	Compressor discharge temperature sensor TP is in open circuit or has short circuited
EC55	IGBT temperature sensor TH is in open circuit or has short circuited
EC56	Evaporator coil outlet temperature sensor T2B is in open circuit or has short circuited(for free-match outdoor units)
EC05	Open circuit or short circuit of outdoor temperature sensor or outdoor unit EEPROM parameter error
EC0d	Outdoor unit malfunction
Eh60	Indoor room temperature sensor T1 is in open circuit or has short circuited
Eh61	Evaporator coil middle temperature sensor T2 is in open circuit or has short circuited
EC71	Over-current protection of outdoor external fan
EC75	Outdoor external fan driver module protection
EC72	Phase failure of outdoor external fan
EC74	Outdoor external fan current sampling bias fault
EC73	Zero speed failure of outdoor external fan
EC07	The outdoor fan speed is operating outside of the normal range(
Eh0b	Indoor PCB/Display board communication error
EL0C	Refrigerant leakage detection
Eh0H	Rf module failure
Eh0L	Indoor display board EEPROM parameter error
FL09	Indoor and outdoor mismatch malfunction
PC00	IPM malfunction or IGBT over-strong current protection
PC10	Over low voltage protection
PC11	Over voltage protection

PC 12	DC voltage protection
PC 01	Over voltage or over low voltage protection
PC 02	Top temperature protection of compressor or High temperature protection of IPM module or High pressure protection
PC 40	Communication error between outdoor main chip and compressor driven chip
PC 41	Current Input detection protection
PC 42	Compressor start error
PC 43	Compressor lack of phase (3 phase) protection
PC 44	No speed protection
PC 45	341PWM error
PC 46	Compressor speed malfunction
PC 49	Compressor over current protection
PC 4A	Outdoor zero fire line is wrong
PC 4b	Outdoor phase sequence fault
PC 4c	Lack of phase
PC 04	Inverter compressor drive error
PC 06	Compressor discharge temperature protection
PC 08	Outdoor current protection
PH 09	Anti-cold air in heating mode
PC 0F	PFC module protection
PC 30	High pressure protection
PC 31	Low pressure protection
PC 32	Low pressure fault
PC 03	Pressure protection
PC 0L	Outdoor low temperature protection
PH 90	Evaporator coil temperature over high protection
PH 91	Evaporator coil temperature over low Protection
PC 0R	Condenser high temperature protection
LH 00	Frequency limit caused by T2
LC 01	Frequency limit caused by T3
LC 02	Frequency limit caused by TP
LC 05	Frequency limit caused by voltage
LC 03	Frequency limit caused by current
LC 06	Frequency limit caused by PFC
LC 30	Frequency limit caused by high pressure
LC 31	Frequency limit caused by low pressure
LH 07	Frequency limit caused by remote controller

---

## (. Error Diagnosis and Troubleshooting Without Error Code

### WARNING

Be sure to turn off unit before any maintenance to prevent damage or injury.

#### (.1 Remote maintenance

**SUGGESTION:** When troubles occur, please check the following points with customers before field maintenance.

No.	Problem	Solution
1	Unit will not start	13-14
2	The power switch is on but fans will not start	13-14
3	The temperature on the display board cannot be set	13-14
4	Unit is on but the wind is not cold(hot)	13-14
5	Unit runs, but shortly stops	13-14
6	The unit starts up and stops frequently	13-14
7	Unit runs continuously but insufficient cooling(heating)	13-14
8	Cool can not change to heat	13-14
9	Unit is noisy	13-14

---

## (.2 Field maintenance

	Problem	Solution
1	Unit will not start	15-16
2	Compressor will not start but fans run	15-16
3	Compressor and condenser (outdoor) fan will not start	15-16
4	Evaporator (indoor) fan will not start	15-16
5	Condenser (Outdoor) fan will not start	15-16
6	Unit runs, but shortly stops	15-16
7	Compressor short-cycles due to overload	15-16
8	High discharge pressure	15-16
9	Low discharge pressure	15-16
10	High suction pressure	15-16
11	Low suction pressure	15-16
12	Unit runs continuously but insufficient cooling	15-16
13	Too cool	15-16
14	Compressor is noisy	15-16
15	Horizontal louver can not revolve	15-16

1.Remote Maintenance	Electrical Circuit				Refrigerant Circuit													
Possible causes of trouble	Power failure																	
	The main power tripped																	
	Loose connections																	
	Faulty transformer																	
	The voltage is too high or too low																	
	The remote control is powered off																	
	Broken remote control																	
	Dirty air filter																	
	Dirty condenser fins																	
	The setting temperature is higher/lower than the room's(cooling/heating)																	
	The ambient temperature is too high/low when the mode is cooling/heating																	
	Fan mode																	
	SILENCE function is activated(optional function)																	
Frosting and defrosting frequently																		
Unit will not start	☆	☆	☆	☆														
The power switch is on but fans will not start			☆	☆	☆													
The temperature on the display board cannot be set						☆	☆											
Unit is on but the wind is not cold(hot)										☆	☆	☆						
Unit runs, but shortly stops					☆					☆	☆							
The unit starts up and stops frequently					☆						☆					☆		
Unit runs continuously but insufficient cooling/heating)								☆	☆	☆	☆			☆				
Cool can not change to heat																		
Unit is noisy																		
Test method / remedy	Test voltage																	
	Close the power switch																	
	Inspect connections - tighten																	
	Change the transformer																	
	Test voltage																	
	Replace the battery of the remote control																	
	Replace the remote control																	
	Clean or replace																	
	Clean																	
	Adjust the setting temperature																	
	Turn the AC later																	
	Adjust to cool mode																	
	Turn off SILENCE function.																	
Turn the AC later																		

1.Remote Maintenance	Others					
Possible causes of trouble	Heavy load condition	Loosen hold down bolts and / or screws	Bad airproof	The air inlet or outlet of either unit is blocked	Interference from cell phone towers and remote boosters	Shipping plates remain attached
Unit will not start						
The power switch is on but fans will not start					☆	
The temperature on the display board cannot be set						
Unit is on but the wind is not cold(hot)						
Unit runs, but shortly stops						
The unit starts up and stops frequently				☆		
Unit runs continuously but insufficient cooling(heating)	☆		☆	☆		
Cool can not change to heat						
Unit is noisy		☆				☆
Test method / remedy	Check heat load	Tighten bolts or screws	Close all the windows and doors	Remove the obstacles	Reconnect the power or press ON/OFF button on remote control to restart operation	Remove them

2.Field Maintenance	Refrigerant Circuit														Others									
Possible causes of trouble	Compressor stuck	Shortage of refrigerant	Restricted liquid line	Dirty air filter	Dirty evaporator coil	Insufficient air through evaporator coil	Overcharge of refrigerant	Dirty or partially blocked condenser	Air or incompressible gas in refrigerant cycle	Short cycling of condensing air	High temperature condensing medium	Insufficient condensing medium	Broken compressor internal parts	Inefficient compressor	Expansion valve obstructed	Expansion valve or capillary tube closed completely	Leaking power element on expansion valve	Poor installation of feeler bulb	Heavy load condition	Loosen hold down bolts and / or screws	Shipping plates remain attached	Poor choices of capacity	Contact of piping with other piping or external plate	
Unit will not start																								
Compressor will not start but fans run	☆																							
Compressor and condenser (outdoor) fan will not start																								
Evaporator (indoor) fan will not start																								
Condenser (Outdoor) fan will not start																								
Unit runs, but shortly stops		☆	☆				☆	☆								☆	☆							
Compressor short-cycles due to overload		☆					☆	☆																
High discharge pressure							☆	☆	☆	☆	☆													
Low discharge pressure		☆												☆										
High suction pressure							☆							☆				☆	☆					
Low suction pressure		☆	☆	☆	☆	☆								☆	☆	☆								
Unit runs continuously but insufficient cooling		☆	☆	☆	☆	☆		☆	☆	☆				☆					☆			☆		
Too cool																								
Compressor is noisy							☆						☆							☆	☆		☆	
Horizontal louver can not revolve																								
Test method / remedy	Replace the compressor	Leak test	Replace restricted part	Clean or replace	Clean coil	Check fan	Change charged refrigerant volume	Clean condenser or remove obstacle	Purge, evacuate and recharge	Remove obstruction to air flow	Remove obstruction in air or water flow	Remove obstruction in air or water flow	Replace compressor	Test compressor efficiency	Replace valve	Replace valve	Replace valve	Fix feeler bulb	Check heat load	Tighten bolts or screws	Remove them	Choose AC of lager capacity or add the number of AC	Rectify piping so as not to contact each other or with external plate	

2.Field Maintenance	Electrical Circuit														
Possible causes of trouble	Power failure	Blown fuse or varistor	Loose connections	Shorted or broken wires	Safety device opens	Faulty thermostat / room temperature sensor	Wrong setting place of temperature sensor	Faulty transformer	Shorted or open capacitor	Faulty magnetic contactor for compressor	Faulty magnetic contactor for fan	Low voltage	Faulty stepping motor	Shorted or grounded compressor	Shorted or grounded fan motor
Unit will not start	☆	☆	☆	☆	☆			☆							
Compressor will not start but fans run				☆		☆			☆	☆				☆	
Compressor and condenser (outdoor) fan will not start				☆		☆				☆					
Evaporator (indoor) fan will not start				☆					☆		☆				☆
Condenser (Outdoor) fan will not start				☆		☆			☆		☆				☆
Unit runs, but shortly stops										☆		☆			
Compressor short-cycles due to overload										☆		☆			
High discharge pressure															
Low discharge pressure															
High suction pressure															
Low suction pressure															
Unit runs continuously but insufficient cooling															
Too cool						☆	☆								
Compressor is noisy															
Horizontal louver can not revolve			☆	☆									☆		
Test method / remedy	Test voltage	Inspect fuse type & size	Inspect connections - tighten	Test circuits with tester	Test continuity of safety device	Test continuity of thermostat / sensor & wiring Place the temperature sensor at the central of the air inlet grille	Check control circuit with tester	Check capacitor with tester	Test continuity of coil & contacts	Test continuity of coil & contacts	Test voltage	Replace the stepping motor	Check resistance with multimeter	Check resistance with multimeter	



## ) Quick Maintenance by Error Code

If you do not have the time to test which specific parts are faulty, you can directly change the required parts according the error code. You can find the parts to replace by error code in the following table.

Part requiring replacement	Error Code						
	EH00/EH0A	EH03	EH60	EH61	EH0b	EU0C	EC56
Indoor PCB	✓	✓	✓	✓	✓	✓	x
Outdoor PCB	x	x	x	x	x	x	✓
Display board	x	x	x	x	✓	x	x
Indoor fan motor	x	✓	x	x	x	x	x
T1 sensor	x	x	✓	x	x	x	x
T2 Sensor	x	x	x	✓	x	✓	x
T2B Sensor	x	x	x	x	x	x	✓
Additional refrigerant	x	x	x	x	x	✓	x

Part requiring replacement	Error Code						
	PC0F	EU01	PC03	PC01	PC02	PC04	PC40
Indoor PCB	x	✓	x	x	x	x	x
Outdoor PCB	✓	✓	✓	✓	✓	✓	✓
Indoor fan motor	x	x	x	x	✓	x	x
Outdoor fan motor	x	x	x	x	x	x	x
Reactor or inductance	✓	✓	x	✓	x	x	x
Compressor	x	x	x	x	x	x	x
Additional refrigerant	x	x	x	x	x	x	x
PFC module	✓	x	x	x	x	x	x
Low pressure protector	x	x	✓	x	x	x	x
High pressure protector	x	x	x	x	✓	x	x
IPM module board	x	x	x	✓	✓	✓	x
Electric control box	x	x	x	x	x	x	✓

Part requiring replacement	Error Code							
	EC 50/EC 05	EC 53	EC 52	EC 54	EC 55	EC 51	EC 07	PC 00
Indoor PCB	x	x	x	x	x	x	x	x
Outdoor PCB	✓	✓	✓	✓	✓	✓	✓	✓
Outdoor fan motor	x	x	x	x	x	x	✓	✓
T3 Sensor	✓	x	✓	x	x	x	x	x
T4 Sensor	✓	✓	x	x	x	x	x	x
TP Sensor	✓	x	x	✓	x	x	x	x
TH Sensor	x	x	x	x	✓	x	x	x
Compressor	x	x	x	x	x	x	x	✓
IPM module board	x	x	x	x	x	x	x	✓

**Note:** For certain models, outdoor PCB could not be removed separately. In this case, the outdoor electric control box should be replaced as a whole.

## \*. Troubleshooting by Error Code

---

## TS01-IDU: Indoor EEPROM parameter error diagnosis and solution

**Description:** Indoor PCB main chip does not receive feedback from EEPROM chip.

**Recommended parts to prepare:**

- Indoor PCB

**Troubleshooting and repair:**

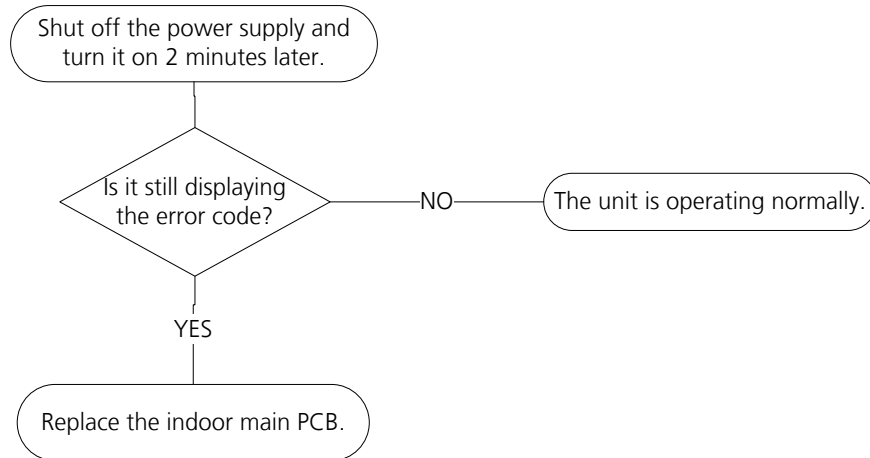

**Remarks:**

**EEPROM:** A read-only memory whose contents can be erased and reprogrammed using a pulsed voltage.

The location of the EEPROM chip on the indoor PCB is shown in the following image:

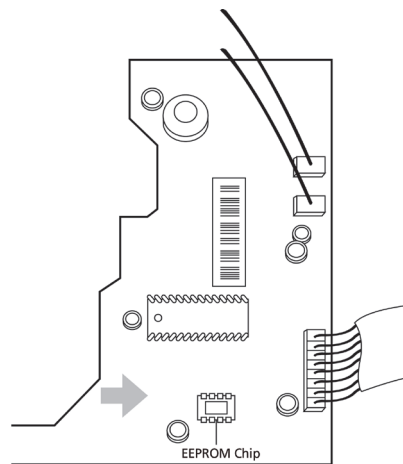

**Note:** This pictures are only for reference, actual appearance may vary.

---

## TS01-ODU: Outdoor EEPROM parameter error or Compressor driven chip EEPROM parameter error diagnosis and solution

**Description:** Outdoor PCB main chip does not receive feedback from EEPROM chip or compressor driven chip.

**Recommended parts to prepare:**

- Outdoor PCB

**Troubleshooting and repair:**

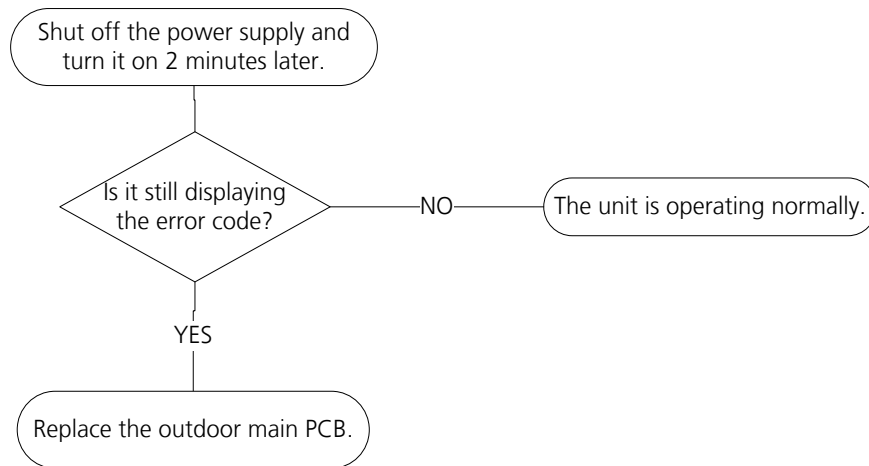

**Remarks:**

**EEPROM:** A read-only memory whose contents can be erased and reprogrammed using a pulsed voltage.

The location of the EEPROM chip on the outdoor PCB is shown in the following image:

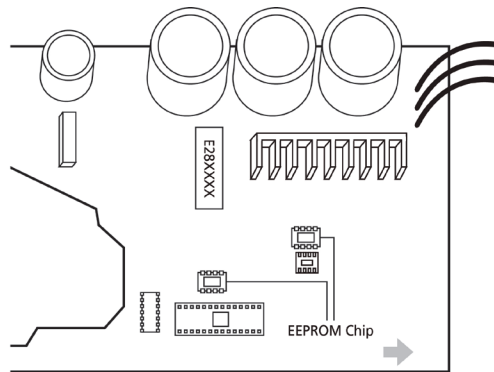

**Note:** For certain models, outdoor PCB could not be removed separately. In this case, the outdoor electric control box should be replaced as a whole. This pictures are only for reference, actual appearance may vary.

## TS02-L-INV: Indoor and outdoor unit communication error diagnosis and solution

**Description:** Indoor unit can not communicate with outdoor unit

**Recommended parts to prepare:**

- Indoor PCB
- Outdoor PCB
- Short-circuited component

**Troubleshooting and repair:**

**S Communication:**

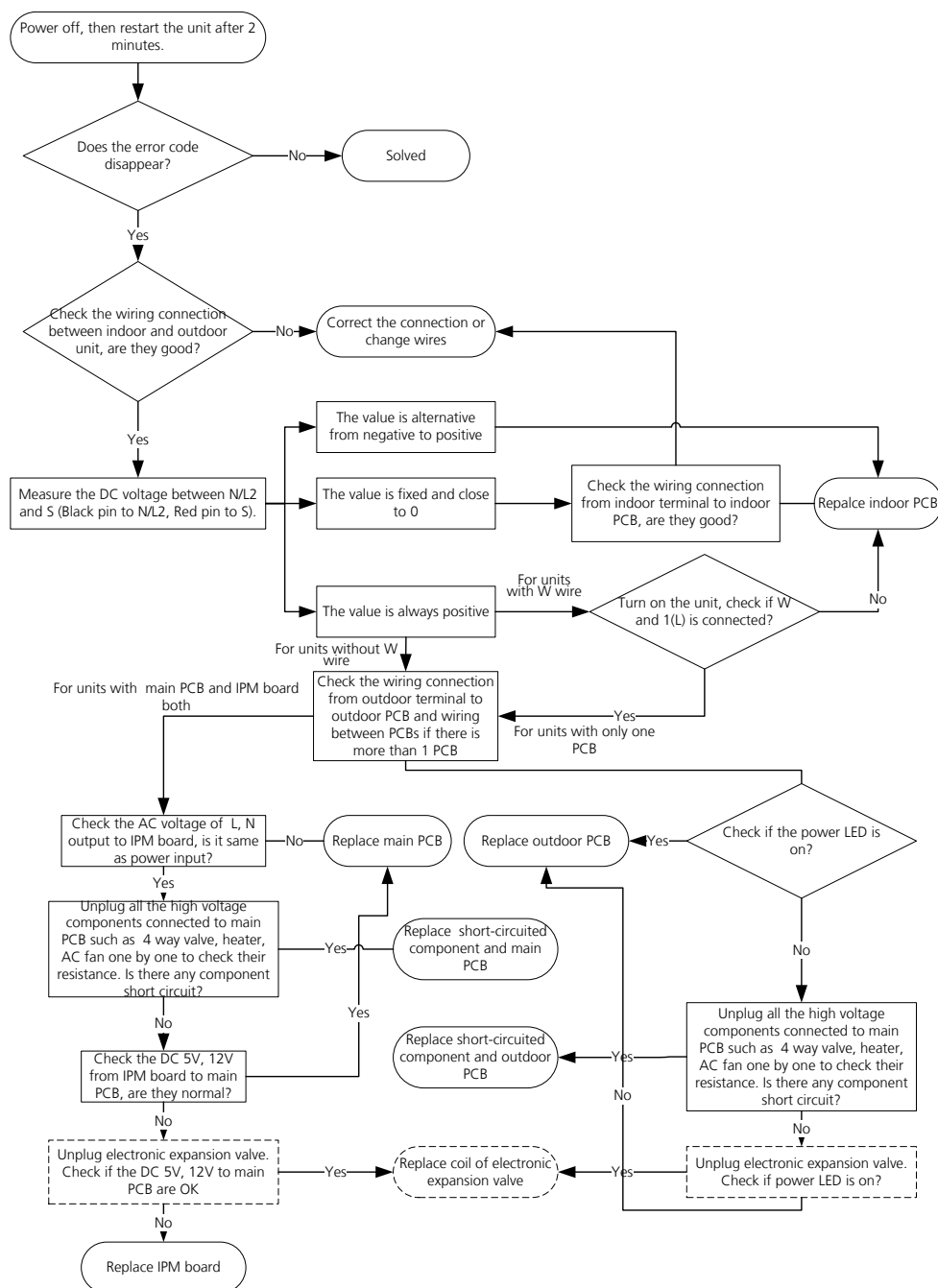

**Note:** For certain models, outdoor PCB could not be removed separately. In this case, the outdoor electric control box should be replaced as a whole.

---

**Remarks:**

- Use a multimeter to test the DC voltage between 2 port(or S or L2 port) and 3 port(or N or S port) of outdoor unit. The red pin of multimeter connects with 2 port(or S or L2 port) while the black pin is for 3 port(or N or S port).
- When AC is normal running, the voltage is moving alternately as positive values and negative values
- If the outdoor unit has malfunction, the voltage has always been the positive value.
- While if the indoor unit has malfunction, the voltage has always been a certain value.

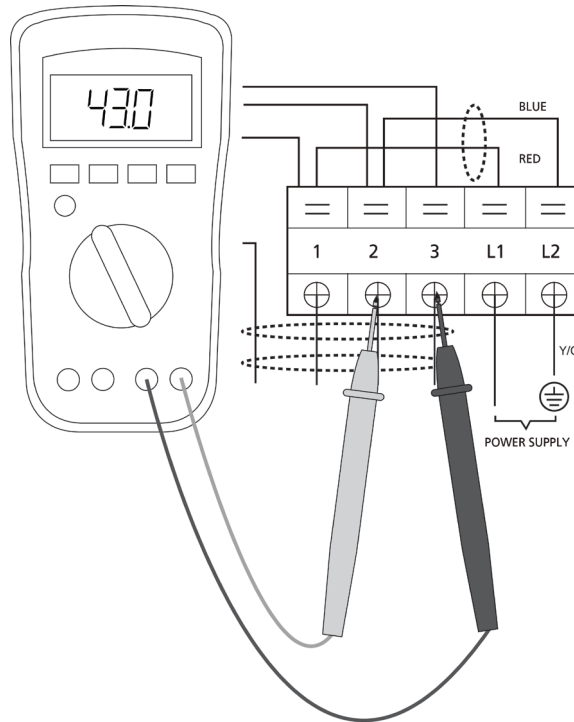

**S and N  
or  
L2 and S  
or  
2 and 3**

- Use a multimeter to test the resistance of the reactor which does not connect with capacitor.
- The normal value should be around zero ohm. Otherwise, the reactor must have malfunction.

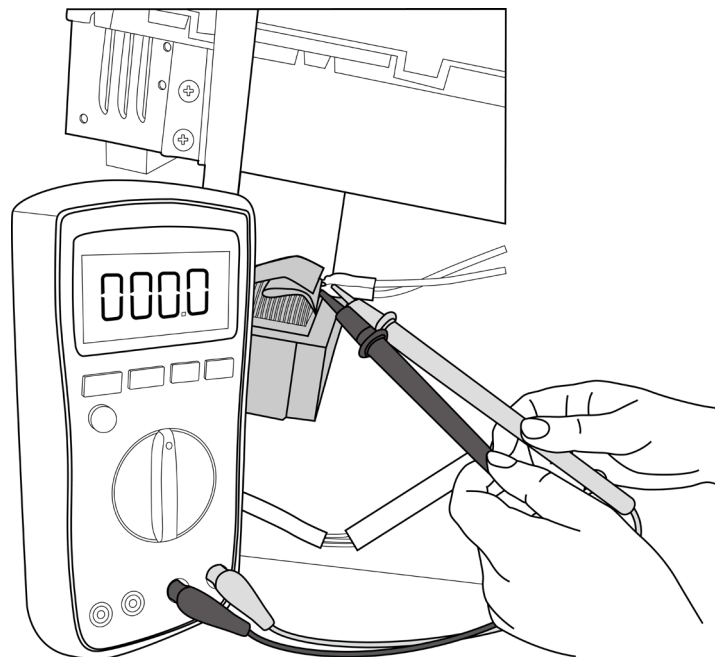

**Note:** The picture and the value are only for reference, actual condition and specific value may vary.

---

## XYE Communication:

### Recommended parts to prepare:

- Signal wires
- Magnet ring
- Indoor PCB
- Outdoor PCB

### Troubleshooting and repair:

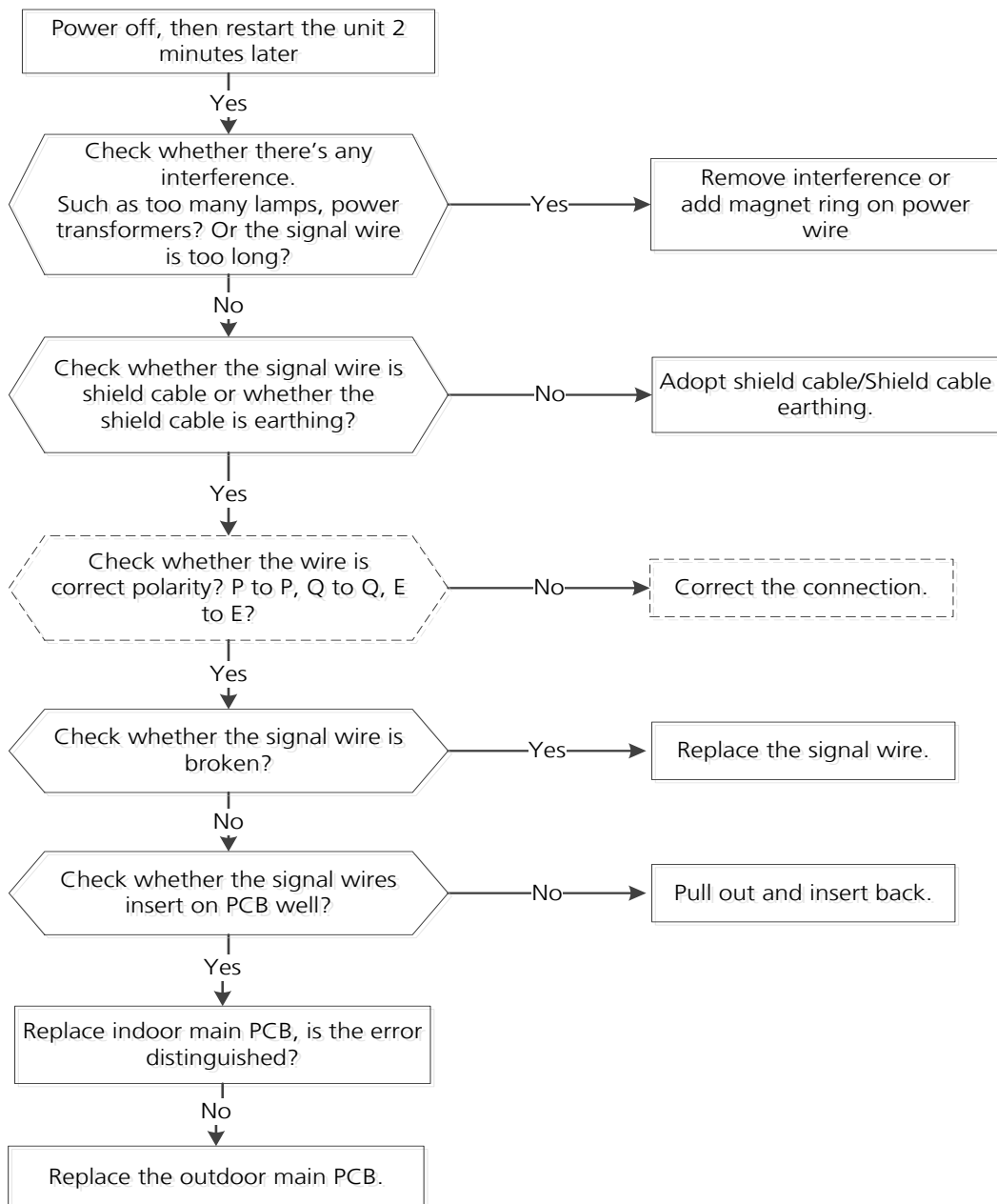

---

## TS04-L-IDU: The Indoor fan speed is operating outside of normal range diagnosis and solution)

**Description:** When indoor fan speed keeps too low or too high for a certain time, the LED displays the failure code and the AC turns off.

### Recommended parts to prepare:

- Connection wires
- Fan assembly
- Fan motor
- Indoor main PCB

### Troubleshooting and repair:

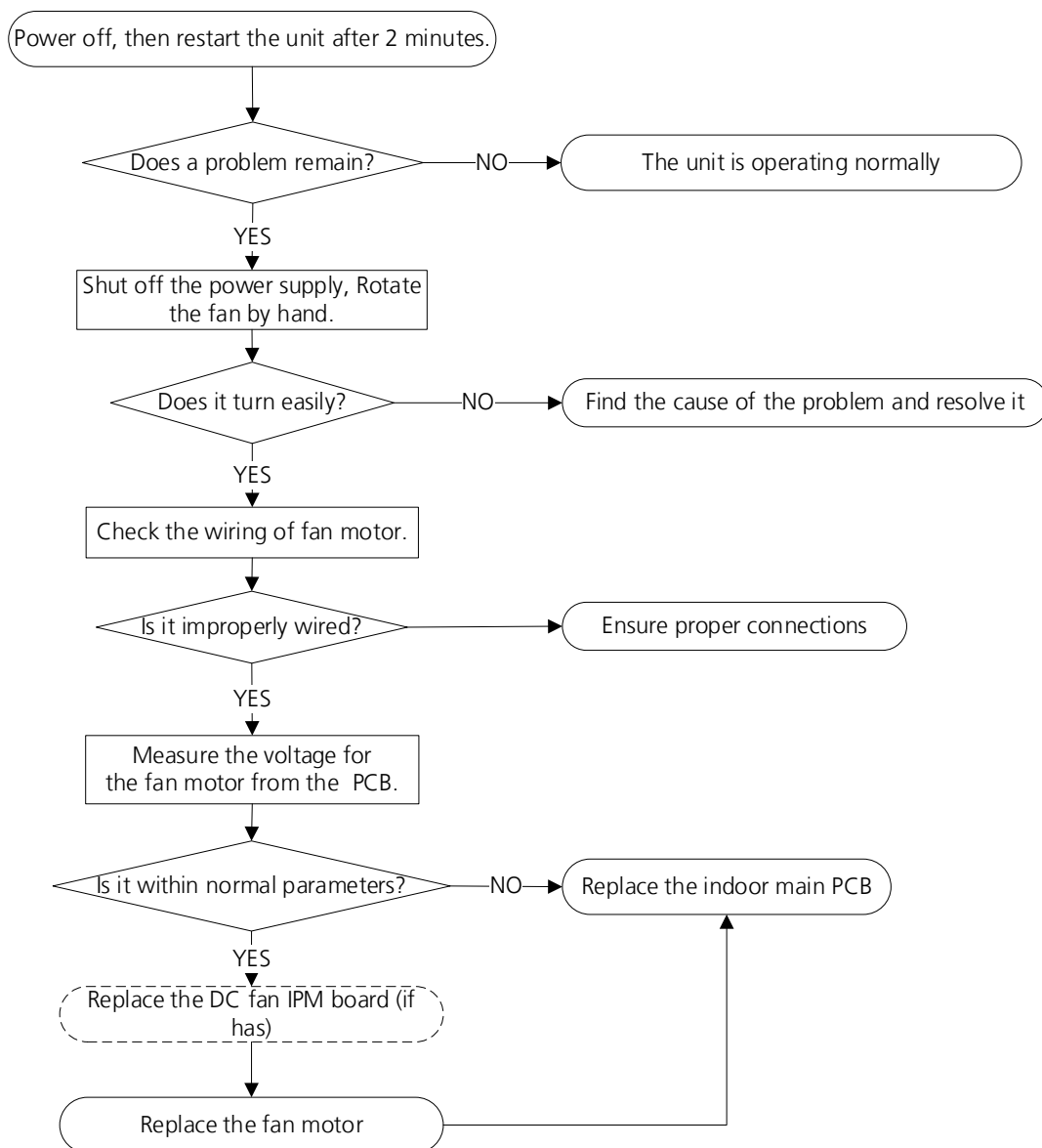



---

**Index:****1. DC Fan Motor(control chip is in fan motor)**

Power on and when the unit is in standby, measure the voltage of pin1-pin3, pin4-pin3 in fan motor connector. If the value of the voltage is not in the range showing in below table, the PCB must has problems and need to be replaced.

- DC motor voltage input and output:

No.	Color	Signal	Voltage
1	Red	Vs/Vm	200V~380V
2	---	---	---
3	Black	GND	0V
4	White	Vcc	13.5-16.5V
5	Yellow	Vsp	0~6.5V
6	Blue	FG	13.5-16.5V

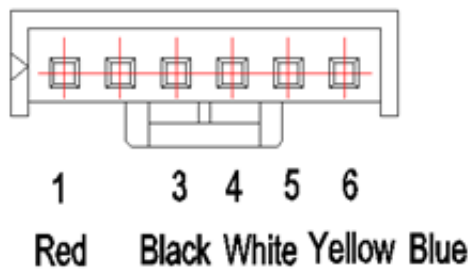

---

## TS04-ODU: The outdoor fan speed is operating outside of normal range diagnosis and solution)

**Description:** When outdoor fan speed keeps too low or too high for a certain time, the LED displays the failure code and the AC turns off.

### Recommended parts to prepare:

- Connection wires
- Fan assembly
- Fan motor
- Outdoor main PCB

### Troubleshooting and repair:

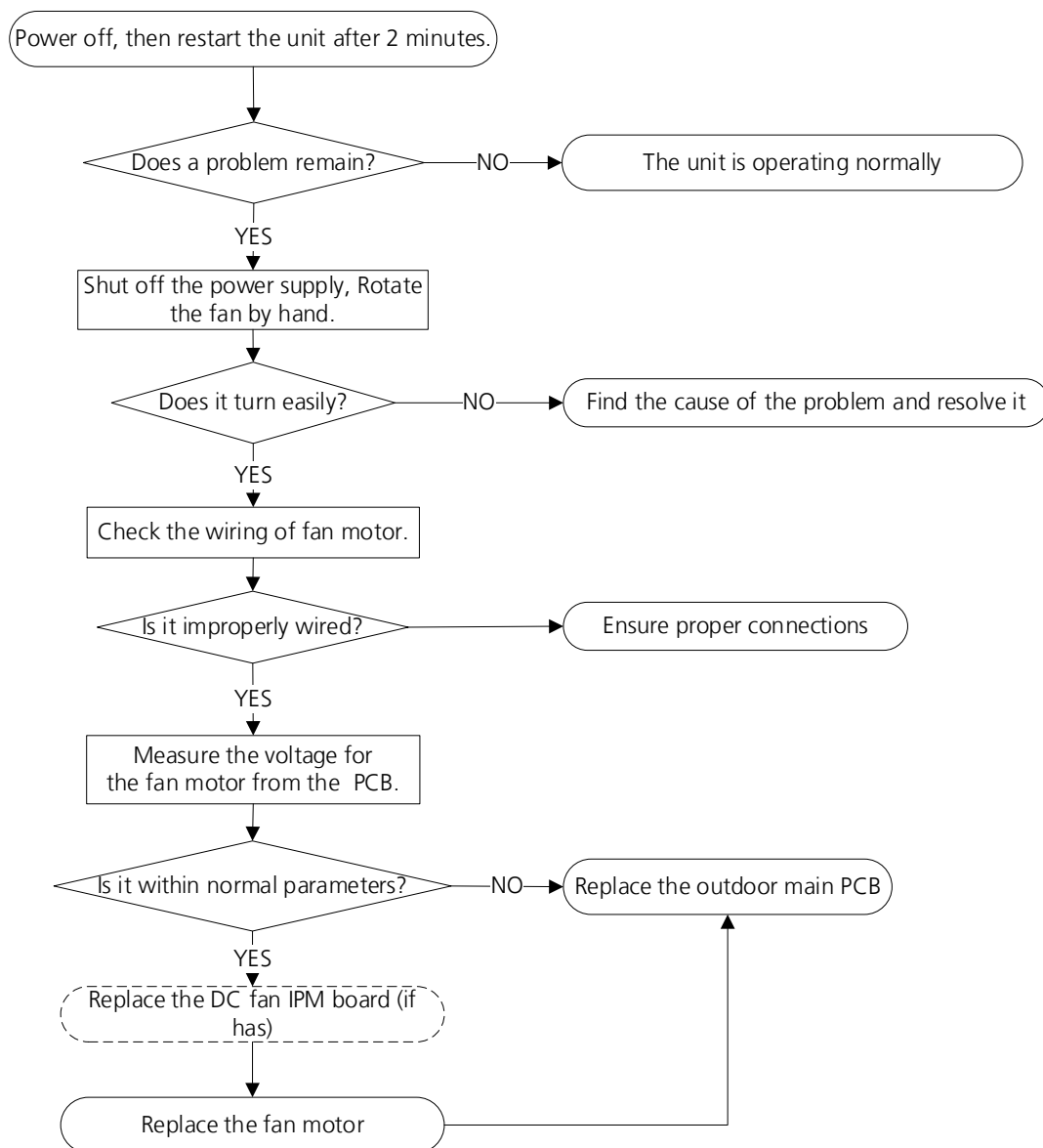

**Note:** For certain models, outdoor PCB could not be removed separately. In this case, the outdoor electric control box should be replaced as a whole.

---

## Index:

### 1. Outdoor DC Fan Motor (control chip is in outdoor PCB)

Release the UVW connector. Measure the resistance of U-V, U-W, V-W. If the resistance is not equal to each other, the fan motor must have problems and need to be replaced. otherwise the PCB must have problems and need to be replaced.

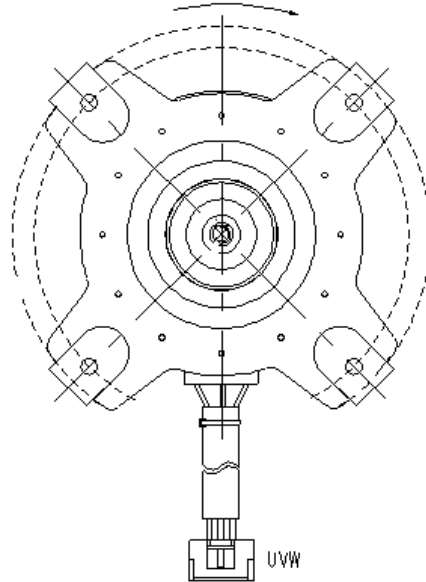

### 2. DC Fan Motor(control chip is in fan motor, single fan)

Power on and when the unit is in standby, measure the voltage of pin1-pin3, pin4-pin3 in fan motor connector. If the value of the voltage is not in the range showing in below table, the PCB must have problems and need to be replaced.

No.	Color	Signal	Voltage
1	Red	Vs/Vm	192V~380V
2	---	---	---
3	Black	GND	0V
4	White	Vcc	13.5-16.5V
5	Yellow	Vsp	0~6.5V
6	Blue	FG	13.5-16.5V

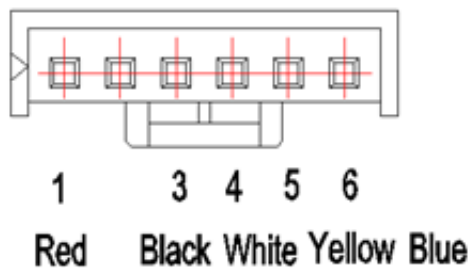

### 3. Outdoor DC Fan IPM Board(for some double fan models)

Power on and when the unit is in standby, measure the voltage of CON1, pin1-pin2 and pin3-pin2 of CN1 in DC motor driver board. If the value of the voltage is not in the range showing in below tables, the outdoor main PCB must has problems and need to be replaced.

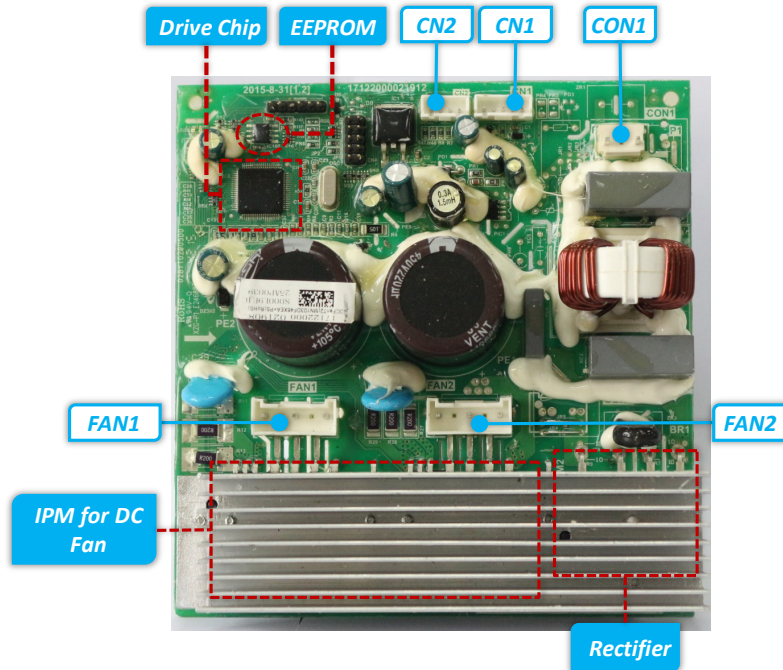

Part	Description	Parameter	Remark
CON1	Power input for the PCB	192-380V/DC	
CN1	Communication with main PCB	DC	
CN2	Test port	5V/DC	For debugging board
FAN1	UVW output for DC fan motor		
FAN2	UVW output for DC fan motor		

CN1 Communication with main PCB

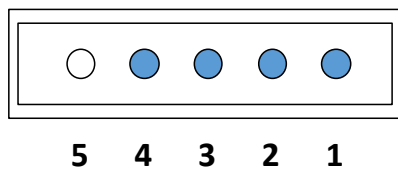

No.	Signal	Voltage
1	Vcc	13.5-16.5V
2	GND	0V
3	Vsp	0~6.5V
4	FG	13.5-16.5V
5	---	---

---

## TS05-IDU: Open circuit or short circuit of indoor temperature sensor(T1, T2) diagnosis and solution

**Description:** If the sampling voltage is lower than 0.06V or higher than 4.94V, the LED displays the failure code.

### Recommended parts to prepare:

- Connection wires
- Sensors
- Indoor main PCB

### Troubleshooting and repair:

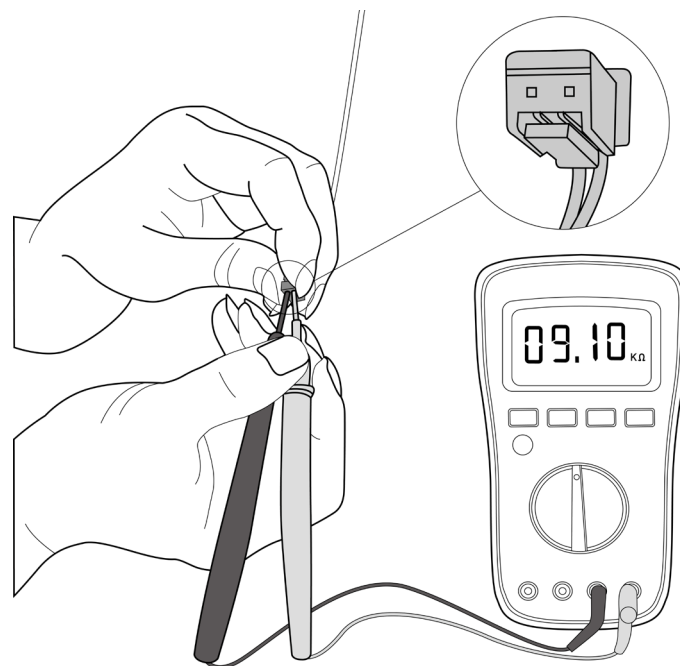
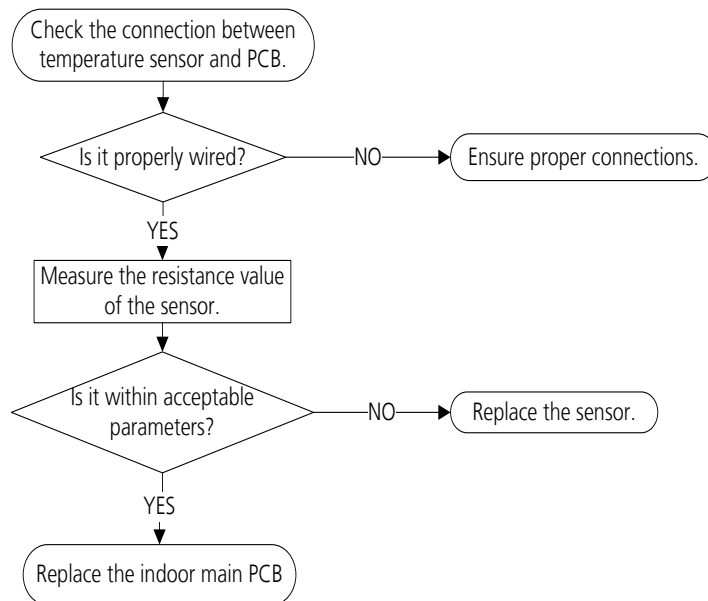

**Note:** This picture and the value are only for reference, actual appearance and value may vary.

## TS05-L-ODU: Open circuit or short circuit of outdoor temperature sensor(T3, T4, TP, T2B) or outdoor unit EEPROM parameter error diagnosis and solution

**Description:** If the sampling voltage is lower than 0.06V or higher than 4.94V, the LED displays the failure code or Outdoor PCB main chip does not receive feedback from EEPROM chip or compressor driven chip.

### Recommended parts to prepare:

- Connection wires
- Sensors
- Outdoor main PCB

### Troubleshooting and repair:

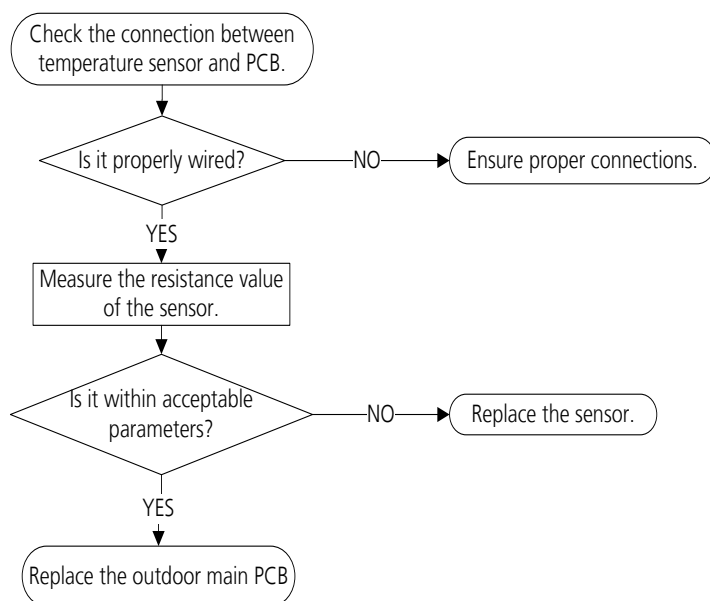

### Remarks:

**EEPROM:** A read-only memory whose contents can be erased and reprogrammed using a pulsed voltage.

The location of the EEPROM chip on the outdoor PCB is shown in the following image:

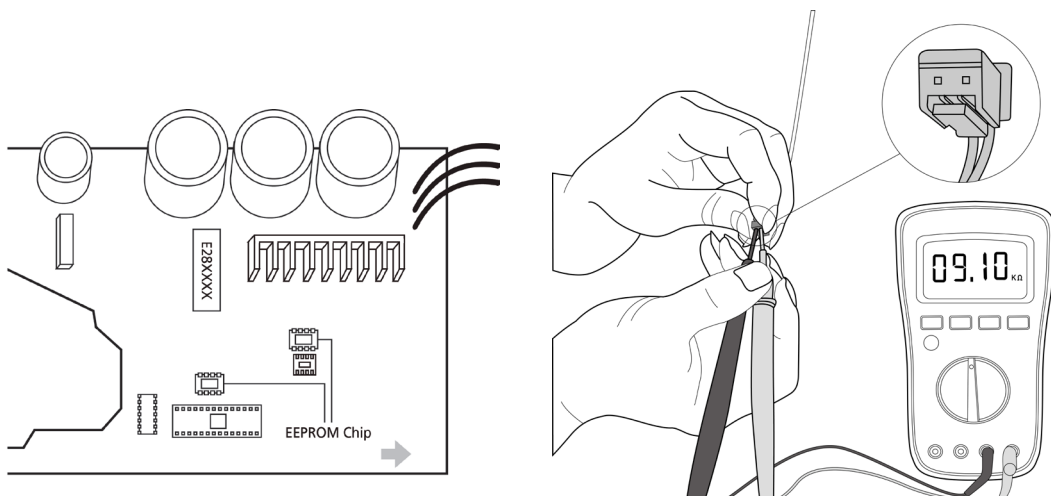

**Note:** For certain models, outdoor PCB could not be removed separately. In this case, the outdoor electric control box should be replaced as a whole. For certain models, outdoor unit uses combination sensor, T3,T4 and TP are the same of sensor. This picture and the value are only for reference, actual appearance and value may vary.

---

## TS05-ODU: Open circuit or short circuit of outdoor temperature sensor(T3, T4, TP, T2B,TH) diagnosis and solution

**Description:** If the sampling voltage is lower than 0.06V or higher than 4.94V, the LED displays the failure code.

### Recommended parts to prepare:

- Connection wires
- Sensors
- Outdoor main PCB

### Troubleshooting and repair:

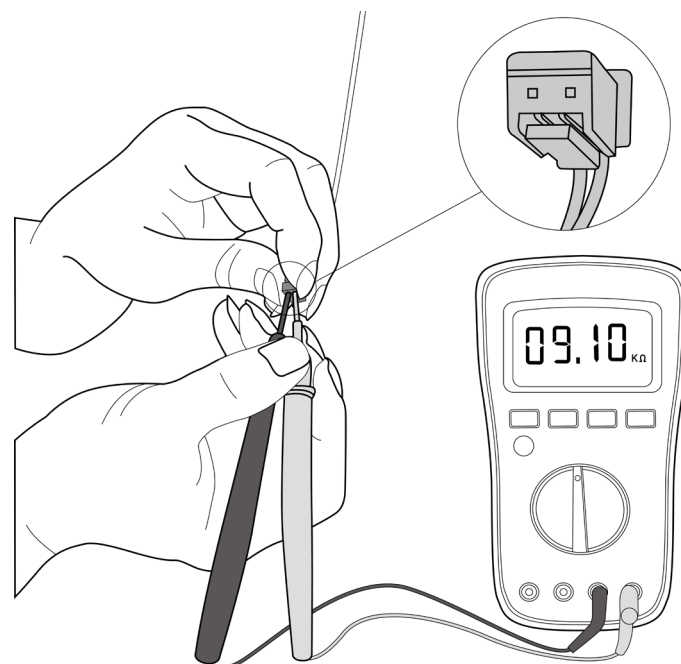
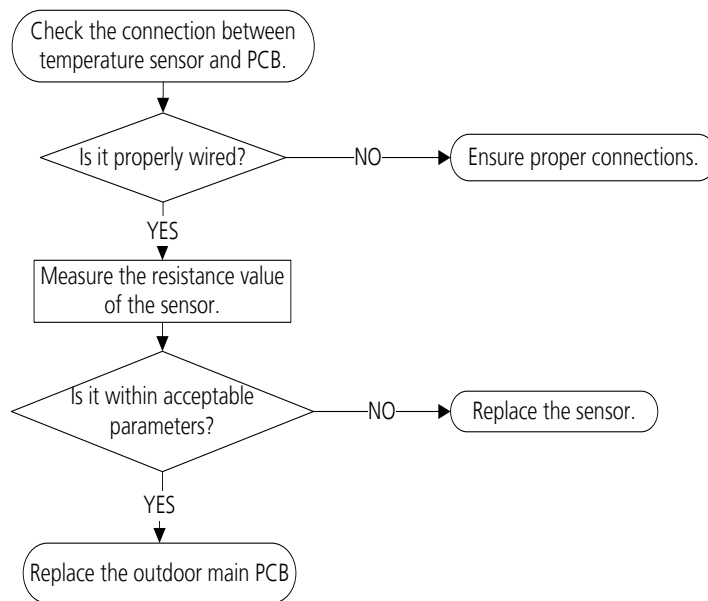

**Note:** For certain models, outdoor PCB could not be removed separately. In this case, the outdoor electric control box should be replaced as a whole. For certain models, outdoor unit uses combination sensor, T3,T4 and TP are the same of sensor. This picture and the value are only for reference, actual appearance and value may vary.

---

## TS06-INV: Refrigerant Leakage Detection diagnosis and solution

For some models,

**Description:** Define the evaporator coil temperature T2 of the compressor just starts running as Tcool.

In the beginning 5 minutes after the compressor starts up, if  $T2 < T_{cool} - 1^{\circ}\text{C}$  ( $1.8^{\circ}\text{F}$ ) does not keep continuous 4 seconds and compressor running frequency higher than 50Hz does not keep for 3 minutes, and this situation happens 3 times, the LED displays the failure code and the AC turns off.

**Recommended parts to prepare:**

- T2 sensor
- Indoor PCB
- Additional refrigerant

**Troubleshooting and repair:**

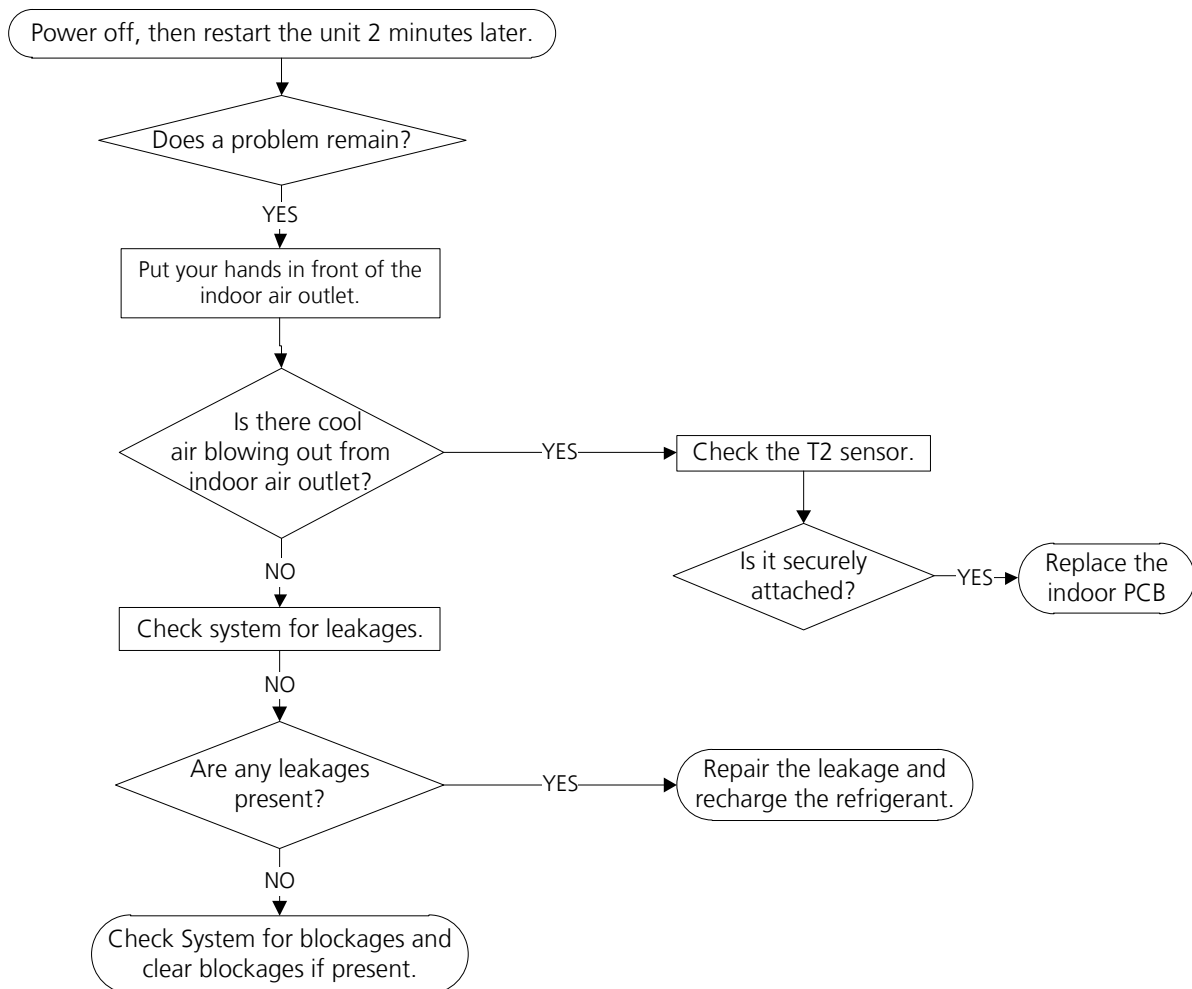



## TS06-INV: Refrigerant Leakage Detection diagnosis and solution

For some models,

### Description:

Judging the abnormality of the refrigeration system according to the number of compressor stops and the changes in operating parameters caused by excessive exhaust temperature.

### Recommended parts to prepare:

- Indoor PCB
- Additional refrigerant

### Troubleshooting and repair:

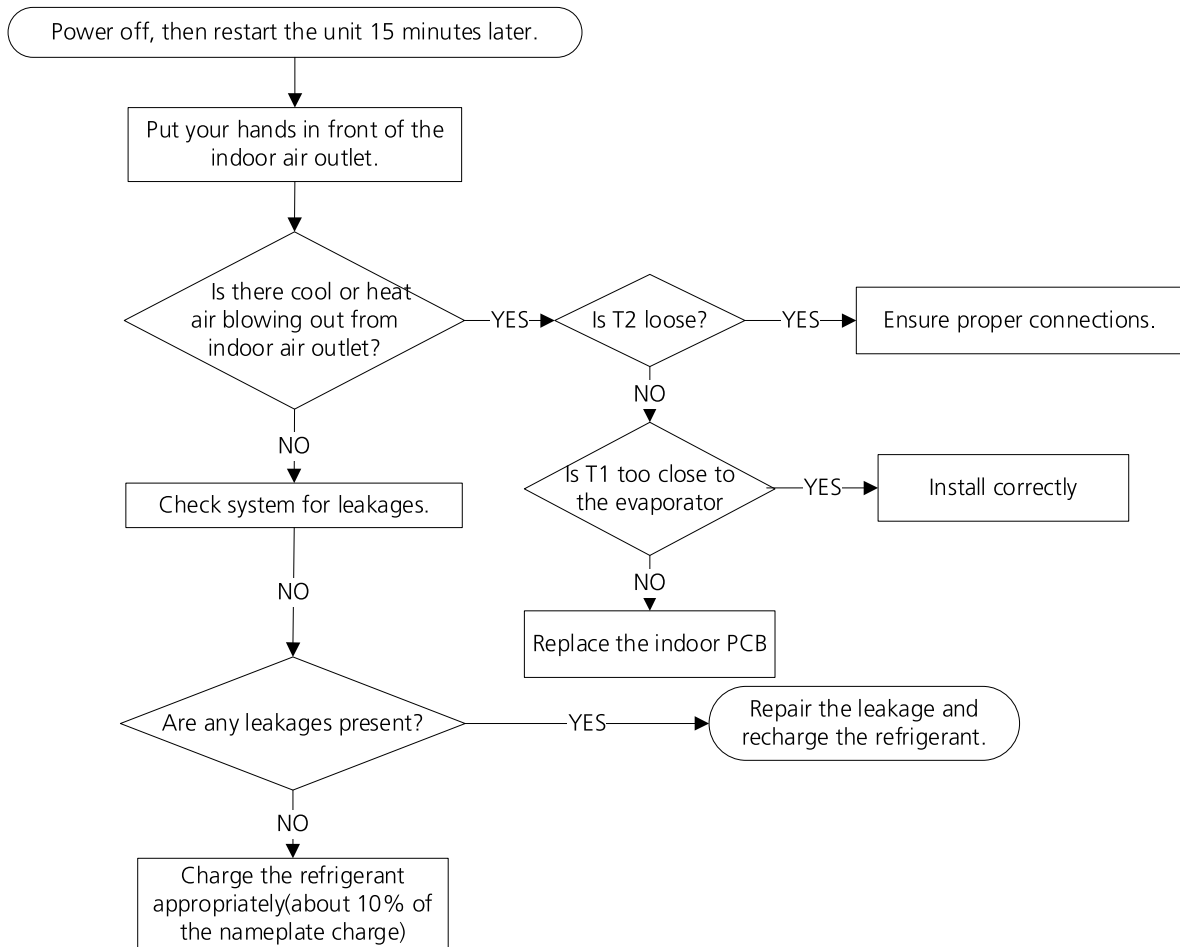

---

## TS07: Indoor PCB / Display board communication error diagnosis and solution

**Description:** Indoor PCB does not receive feedback from the display board.

**Recommended parts to prepare:**

- Communication wire
- Indoor PCB
- Display board

**Troubleshooting and repair:**

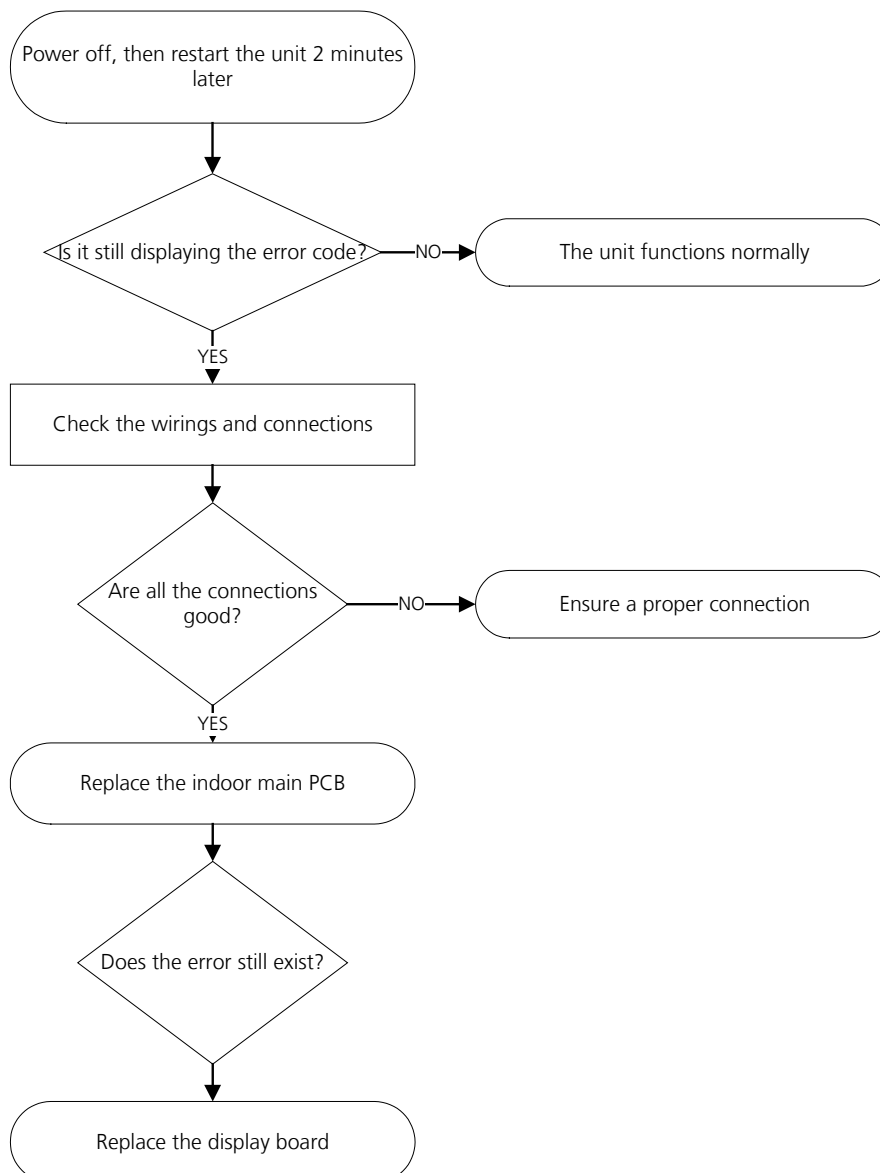

---

## **TS09-L: IPM malfunction or IGBT over-strong current protection or Inverter compressor drive error diagnosis and solution**

**Description:** When the voltage signal the IPM sends to the compressor drive chip is abnormal, the LED displays the failure code and the AC turns off.

Or an abnormal inverter compressor drive is detected by a special detection circuit, including communication signal detection, voltage detection, compressor rotation speed signal detection and so on.

### **Recommended parts to prepare:**

- Connection wires
- IPM module board
- Outdoor fan assembly
- Compressor
- Outdoor PCB
- High-voltage components
- PFC circuit or reactor

### **Troubleshooting and repair:**

First, test the resistance between every two ports of U, V, the W of the IPM and P, N. If any of the results is 0 or close to 0, the IPM is defective. If not, follow the following procedure:

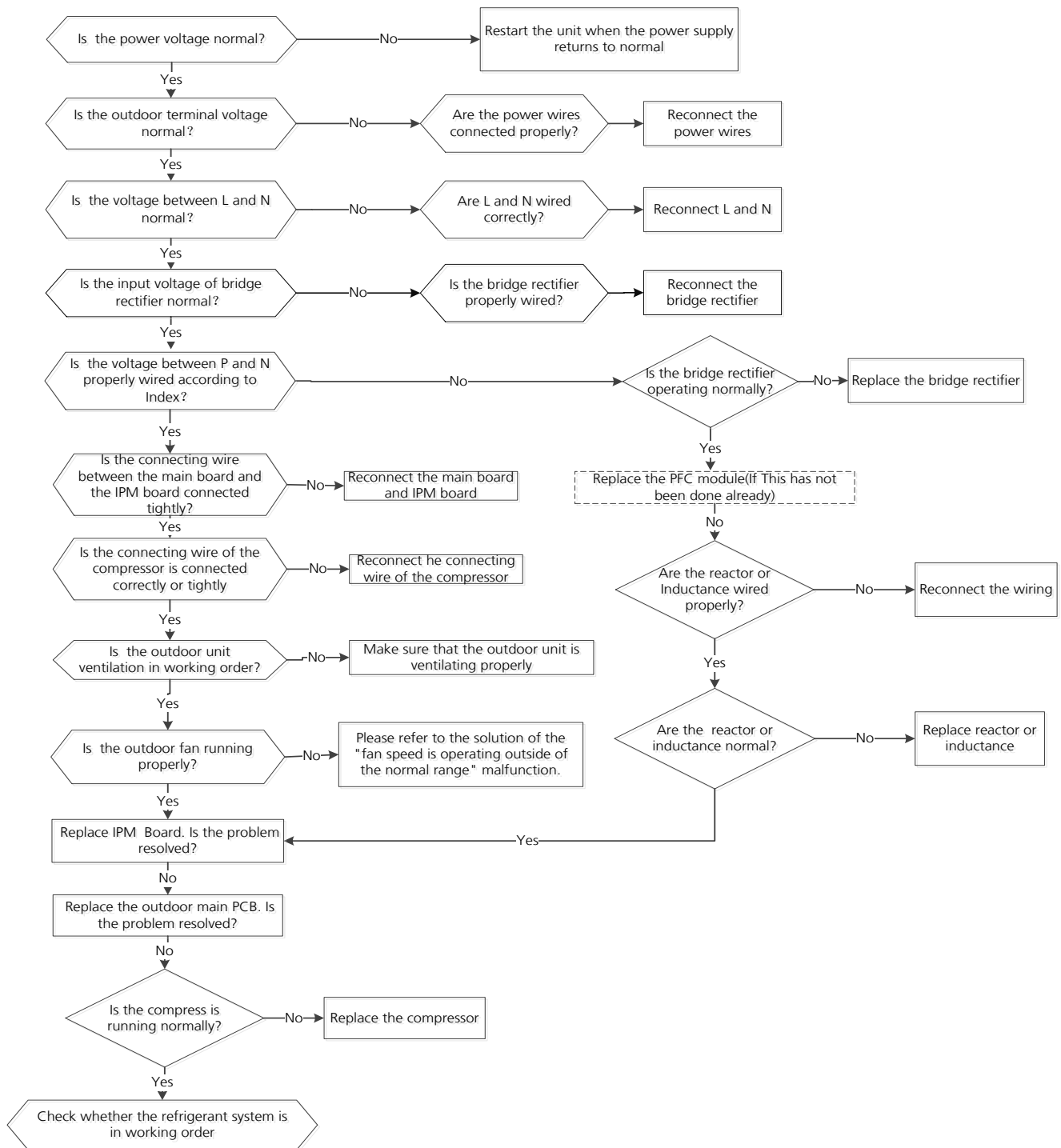

**Note:** For certain models, outdoor PCB could not be removed separately. In this case, the outdoor electric control box should be replaced as a whole.

Index:

## 1. IPM Continuity Check

### **⚠ WARNING**

**Electricity remains in capacitors even when the power supply is off.  
Ensure the capacitors are fully discharged before troubleshooting.**

1. Turn off outdoor unit and disconnect power supply.
2. Discharge electrolytic capacitors and ensure all energy-storage unit has been discharged.
3. Disassemble outdoor PCB or disassemble IPM board.
4. Measure the resistance value between P and U(V, W, N); U(V, W) and N.

Digital tester		Resistance value	Digital tester		Resistance value
(+)Red	(-)Black		(+)Red	(-)Black	
P	N	∞ (Several MΩ)	U	N	∞ (Several MΩ)
	U		V		
	V		W		
	W		-		

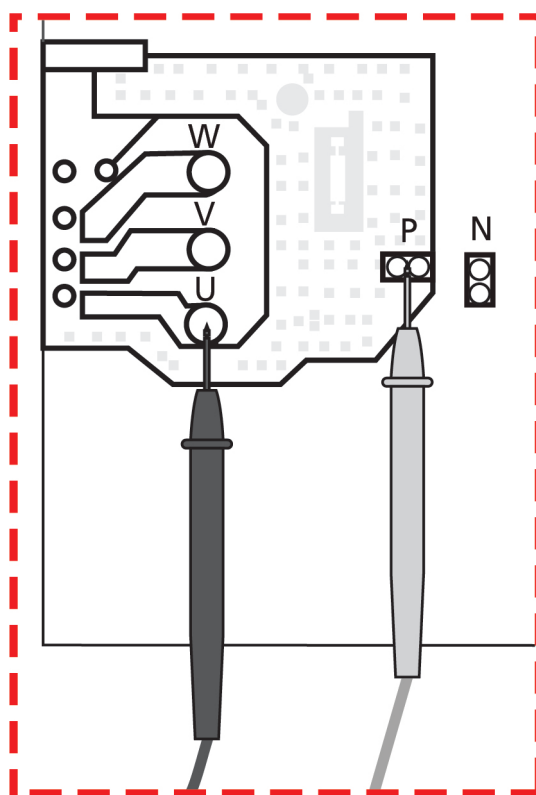

---

## **TS10-L: Over voltage or too low voltage protection diagnosis and solution**

**Description:** Abnormal increases or decreases in voltage are detected by checking the specified voltage detection circuit.

**Recommended parts to prepare:**

- Power supply wires
- IPM module board
- PCB
- Reactor

**Troubleshooting and repair:**

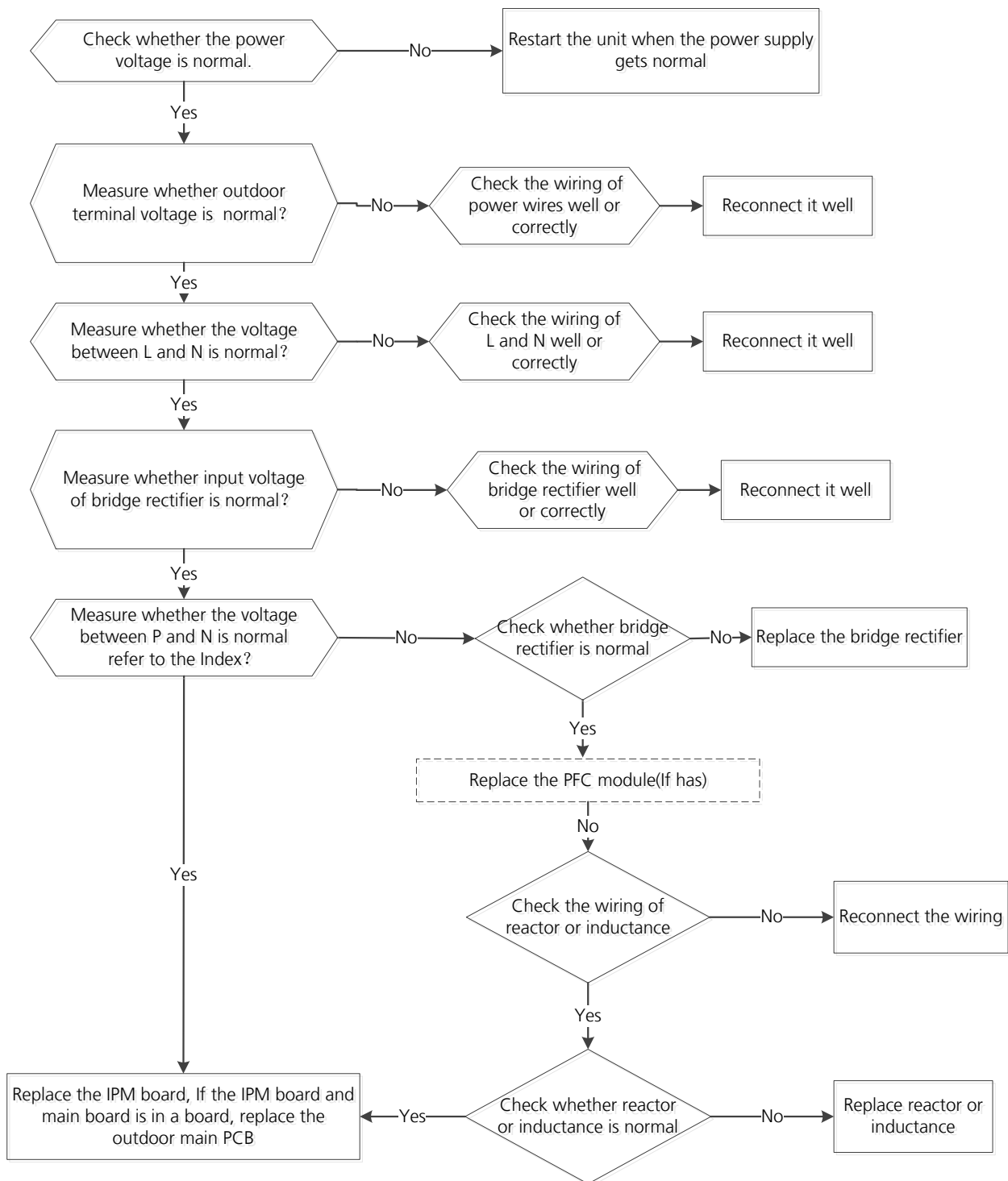

**Note:** For certain models, outdoor PCB could not be removed separately. In this case, the outdoor electric control box should be replaced as a whole.

---

**Index:****1. Normal voltage of P and N**

208-240V(1-phase,3-phase)		380-415V(3-phase)	
In standby			
around 310VDC		around 530VDC	
In operation			
With passive PFC module	With partial active PFC module	With fully active PFC module	/
>200VDC	>310VDC	>370VDC	>450VDC

**2. Reactor Check**

Measure the resistance and voltage (to ground) of the reactor. The normal resistance should be around 0.1 ohm. Otherwise, the reactor must have malfunction.

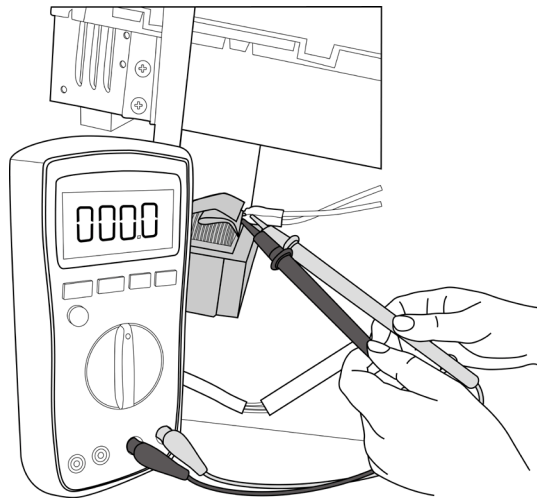



---

## TS11-L: Top temperature protection of compressor diagnosis and solution

**Description:** If the sampling voltage is not 5V, the LED will display the failure.

**Recommended parts to prepare:**

- Connection wires
- Outdoor PCB
- Over load protector

**Troubleshooting and repair:**

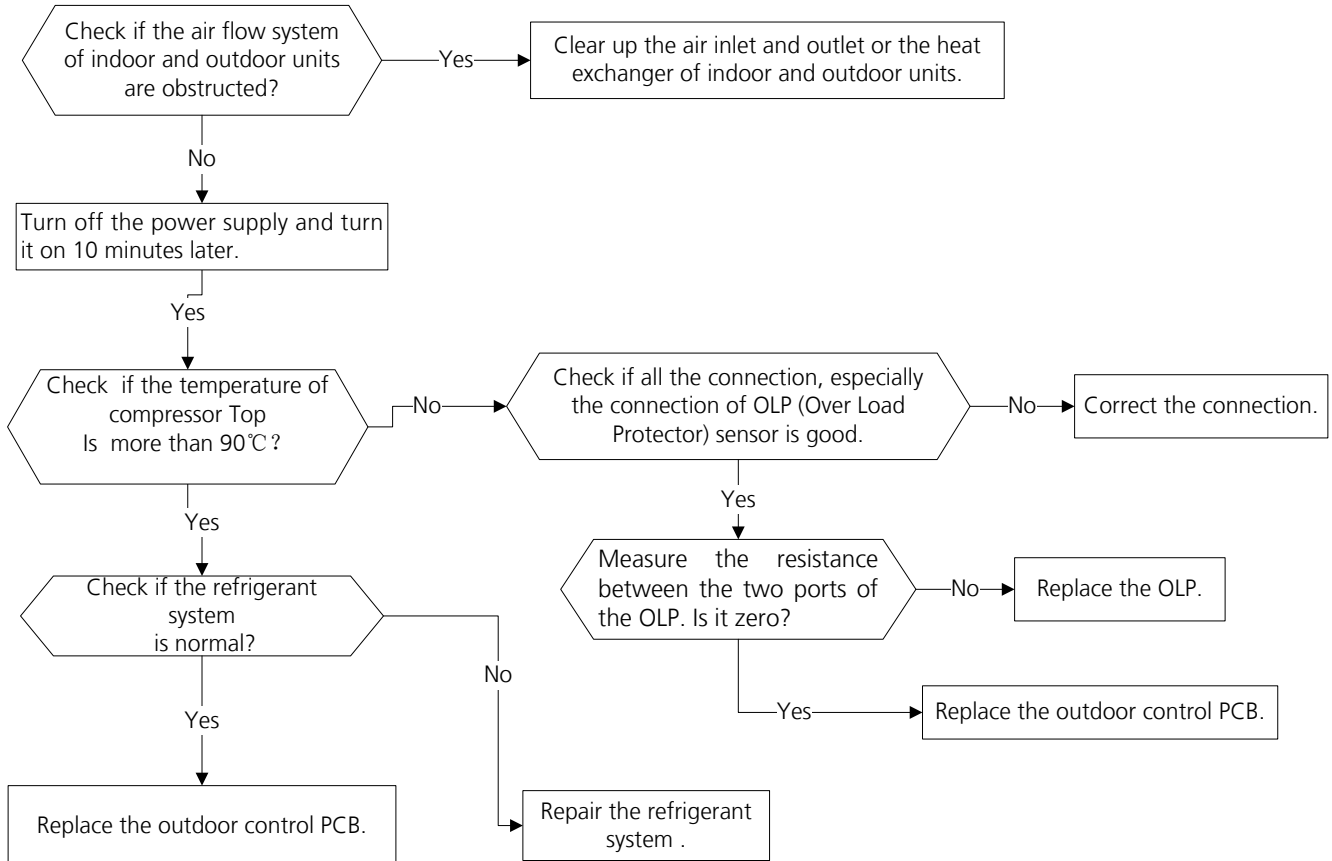

---

## **TS13-INV: Low pressure protection diagnosis and solution**

**Description:** Outdoor pressure switch cut off the system because low pressure is lower than 0.13 MPa, the LED displays the failure code.

### **Recommended parts to prepare:**

- Connection wires
- Outdoor PCB
- Low pressure protector
- Refrigerant

### **Troubleshooting and repair:**

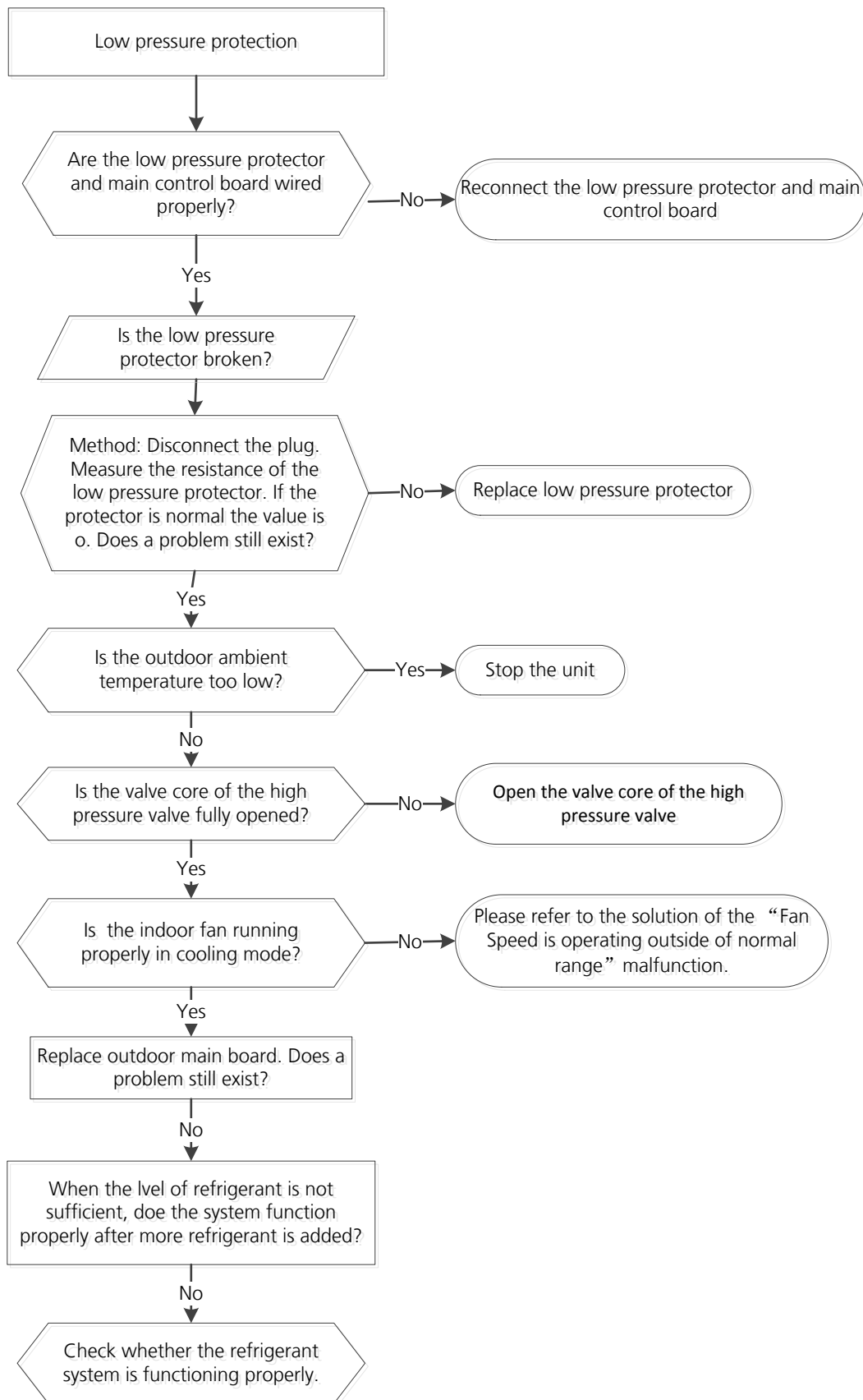

**Note:** For certain models, outdoor PCB could not be removed separately. In this case, the outdoor electric control box should be replaced as a whole.

---

## TS18: Outdoor unit malfunction Diagnosis and Solution

**Description:** The indoor unit detect the outdoor unit is error.

**Recommended parts to prepare:**

- Outdoor unit

**Troubleshooting and repair:**

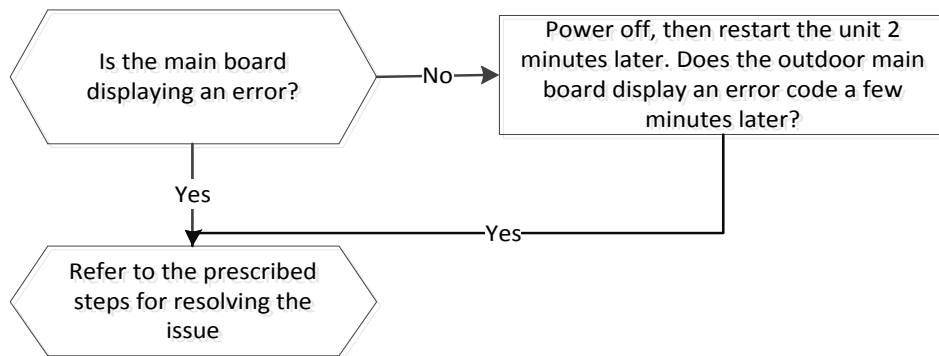

---

## TS30: PFC module protection diagnosis and solution

**Description:** When the voltage signal that IPM send to compressor drive chip is abnormal, the LED displays the failure code and the AC turns off.

### Recommended parts to prepare:

- Connection wires
- Inductance
- Outdoor main PCB
- PFC module

### Troubleshooting and repair:

At first test the resistance between every two ports of U, V, W of IPM and P, N. If any result of them is 0 or close to 0, the IPM is defective. Otherwise, please follow the procedure below:

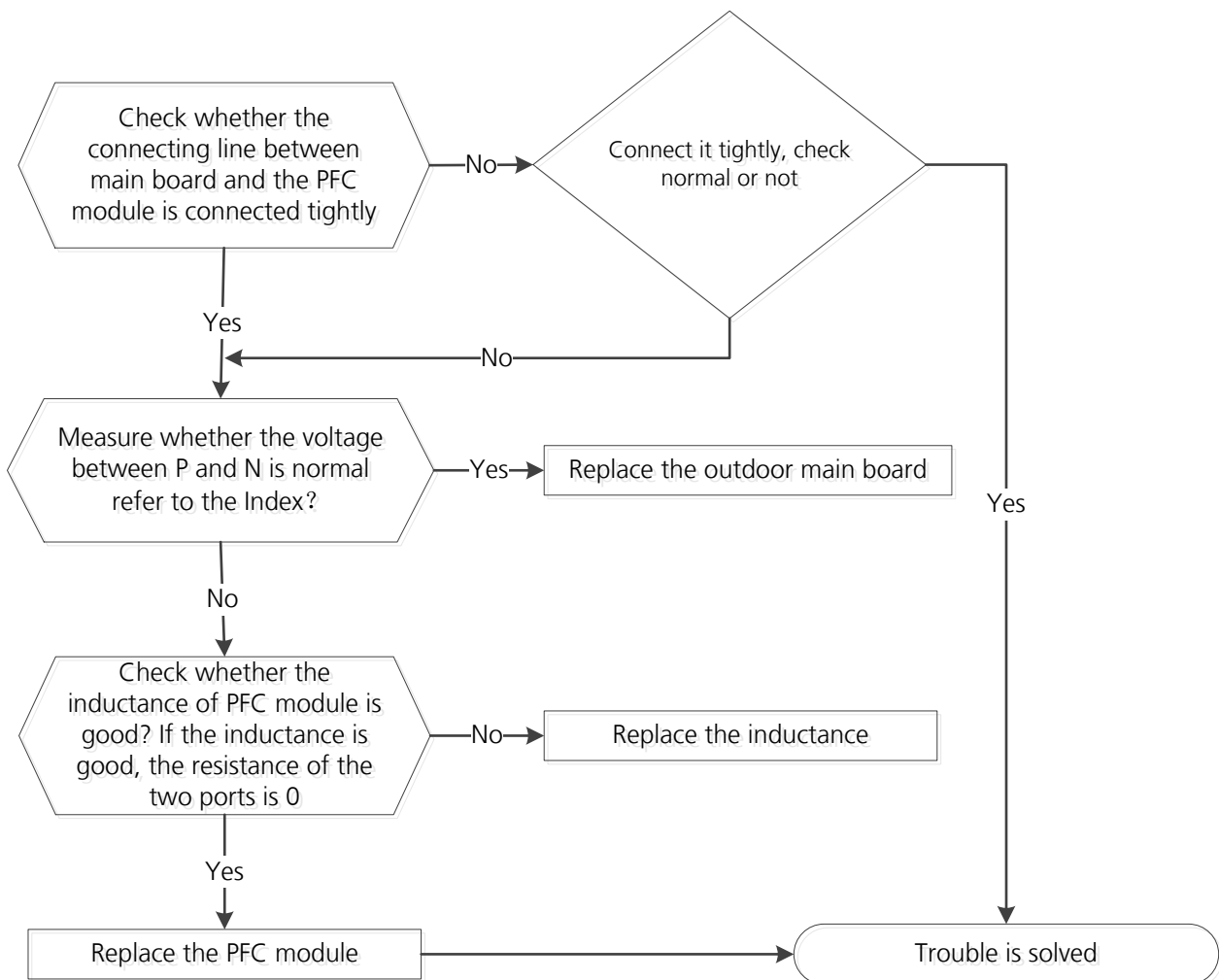

---

**Index:****1. Normal voltage of P and N**

208-240V(1-phase,3-phase)		380-415V(3-phase)	
In standby			
around 310VDC		around 530VDC	
In operation			
With passive PFC module	With partial active PFC module	With fully active PFC module	/
>200VDC	>310VDC	>370VDC	>450VDC

**2. Reactor Check**

Measure the resistance and voltage (to ground) of the reactor. The normal resistance should be around 0.1 ohm. Otherwise, the reactor must have malfunction.

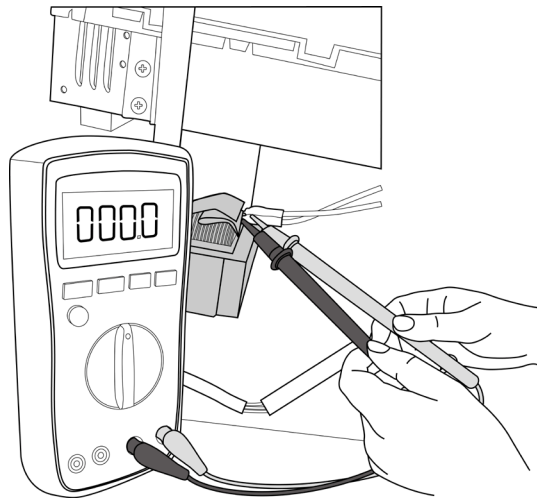

---

## TS33: Communication error between outdoor main chip and compressor driven chip diagnosis and solution

**Description:** The main chip cannot detect the compressor driven chip

**Recommended parts to prepare:**

- Outdoor main PCB
- Electric control box

**Troubleshooting and repair:**

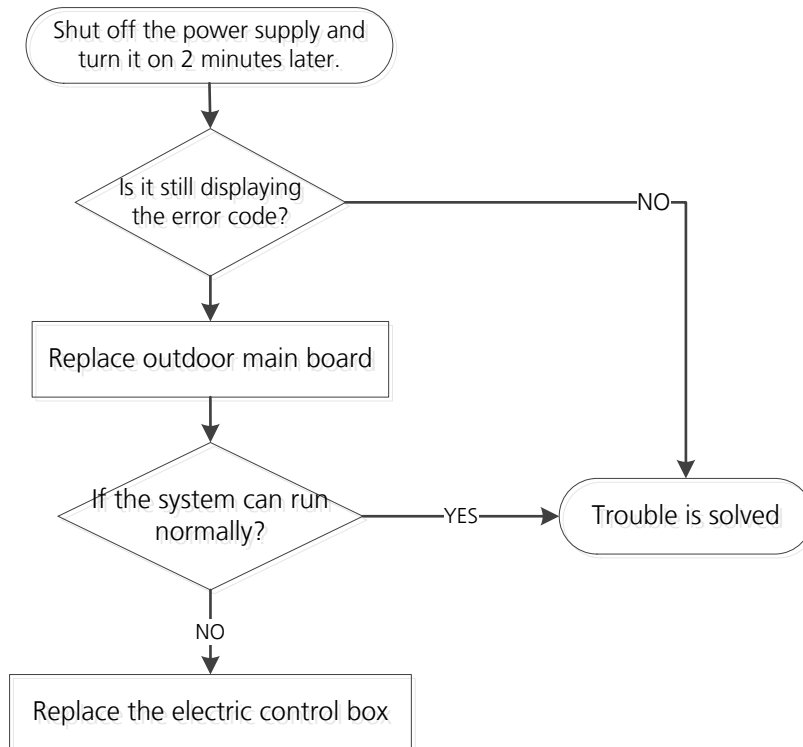

---

### **TS37: Indoor and outdoor mismatch malfunction diagnosis and solution**

**Description:** Indoor and outdoor units are mismatched, the LED displays this code. Please replace the matching indoor or outdoor unit.



## + Check Procedures

### +.1 Temperature Sensor Check

#### **! WARNING**

**Be sure to turn off all power supplies or disconnect all wires to avoid electric shock. Operate after compressor and coil have returned to normal temperature in case of injury.**

1. Disconnect temperature sensor from PCB (Refer to Chapter 5. Indoor Disassembly and Chapter 6. Outdoor Disassembly).
2. Measure the resistance value of the sensor using a multi-meter.
3. Check corresponding temperature sensor resistance value table (Refer to Chapter 8. Appendix).

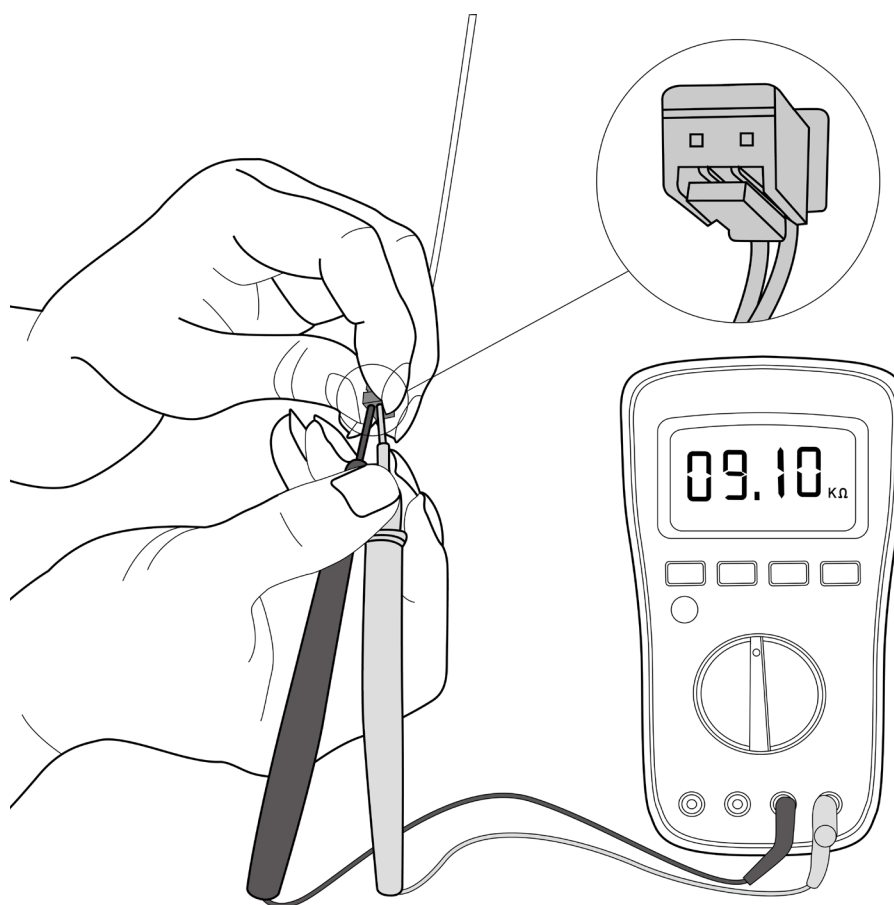

**Note: The picture and the value are only for reference, actual condition and specific value may vary.**

### +.2 Compressor Check

1. Disconnect the compressor power cord from outdoor PCB (Refer to Chapter 6. Outdoor Unit Disassembly).
2. Measure the resistance value of each winding using a multi-meter.
3. Check the resistance value of each winding in the following table.

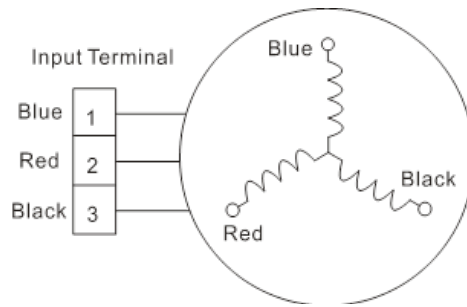

Resistance Value	ATQ420D1TMU	ATQ420D1UMU	KTQ420D1UMU	ATQ420D1SN5A1
Blue-Red	0.37Ω	0.37Ω	0.37Ω	0.37Ω
Blue-Black				
Red-Black				

Resistance Value	ATF235D22TMT	ATF250D22UMT	KTM240D57UMT	KTM240D43UKT
Blue-Red	0.75Ω	0.75Ω	0.62Ω	1.03Ω
Blue-Black				
Red-Black				

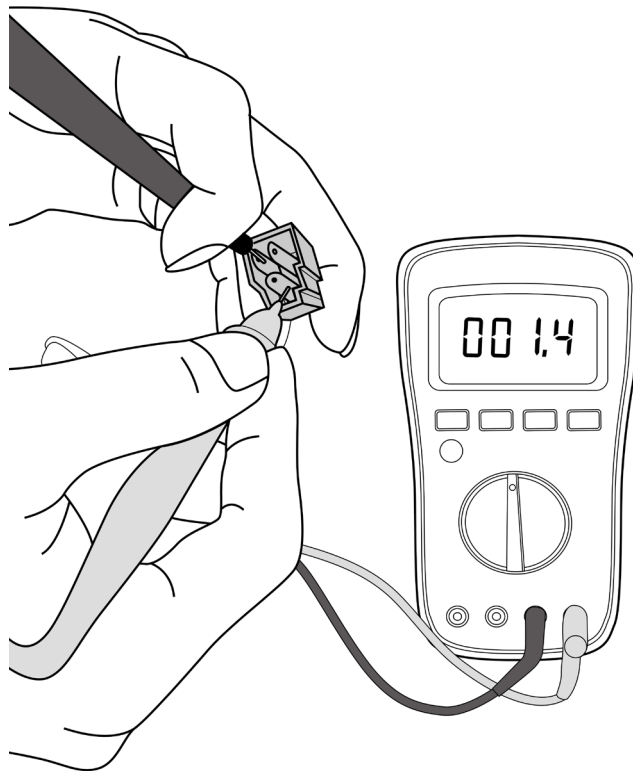

**Note:** The picture and the value are only for reference, actual condition and specific value may vary.

### +3 IPM Continuity Check

#### **⚠ WARNING**

**Electricity remains in capacitors even when the power supply is off. Ensure the capacitors are fully discharged before troubleshooting.**

1. Turn off outdoor unit and disconnect power supply.
2. Discharge electrolytic capacitors and ensure all energy-storage unit has been discharged.
3. Disassemble outdoor PCB or disassemble IPM board.
4. Measure the resistance value between P and U(V, W, N); U(V, W) and N.

Digital tester		Resistance value	Digital tester		Resistance value
(+)Red	(-)Black		(+)Red	(-)Black	
P	N	∞ (Several MΩ)	U	N	∞ (Several MΩ)
	U		V		
	V		W		
	W		-		

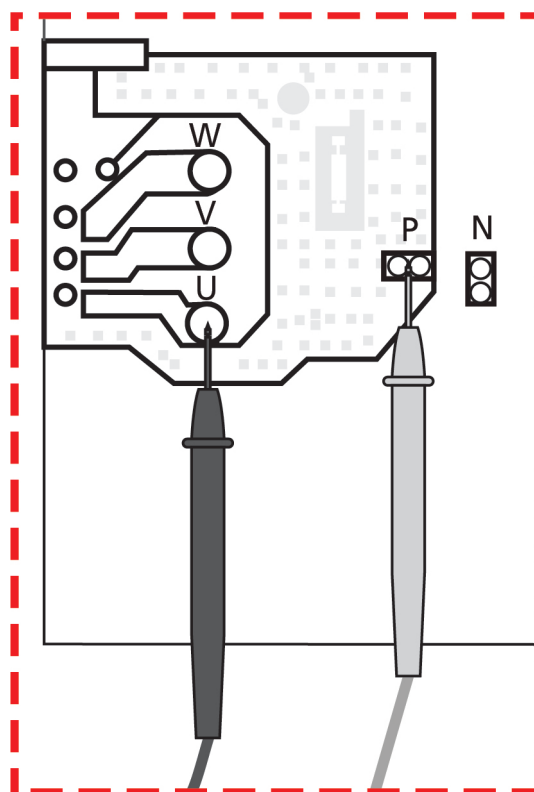

**Note:** The picture and the value are only for reference, actual condition and specific value may vary.

---

**Normal voltage of P and N**

208-240V(1-phase,3-phase)		380-415V(3-phase)	
In standby			
around 310VDC		around 530VDC	
In operation			
With passive PFC module	With partial active PFC module	With fully active PFC module	/
>200VDC	>310VDC	>370VDC	>450VDC

---

# Appendix

## Contents

i)	Temperature Sensor Resistance Value Table for T1, T2, T3, and T4 (°C – K) .....	2
ii)	Temperature Sensor Resistance Value Table for TP (for some units)(°C --K) .....	3
iii)	Pressure On Service Port .....	4

**i) Temperature Sensor Resistance Value Table for T1,T2,T3 and T4 (°C – K)**

°C	°F	K Ohm	°C	°F	K Ohm	°C	°F	K Ohm	°C	°F	K Ohm
-20	-4	115.266	20	68	12.6431	60	140	2.35774	100	212	0.62973
-19	-2	108.146	21	70	12.0561	61	142	2.27249	101	214	0.61148
-18	0	101.517	22	72	11.5	62	144	2.19073	102	216	0.59386
-17	1	96.3423	23	73	10.9731	63	145	2.11241	103	217	0.57683
-16	3	89.5865	24	75	10.4736	64	147	2.03732	104	219	0.56038
-15	5	84.219	25	77	10	65	149	1.96532	105	221	0.54448
-14	7	79.311	26	79	9.55074	66	151	1.89627	106	223	0.52912
-13	9	74.536	27	81	9.12445	67	153	1.83003	107	225	0.51426
-12	10	70.1698	28	82	8.71983	68	154	1.76647	108	226	0.49989
-11	12	66.0898	29	84	8.33566	69	156	1.70547	109	228	0.486
-10	14	62.2756	30	86	7.97078	70	158	1.64691	110	230	0.47256
-9	16	58.7079	31	88	7.62411	71	160	1.59068	111	232	0.45957
-8	18	56.3694	32	90	7.29464	72	162	1.53668	112	234	0.44699
-7	19	52.2438	33	91	6.98142	73	163	1.48481	113	235	0.43482
-6	21	49.3161	34	93	6.68355	74	165	1.43498	114	237	0.42304
-5	23	46.5725	35	95	6.40021	75	167	1.38703	115	239	0.41164
-4	25	44	36	97	6.13059	76	169	1.34105	116	241	0.4006
-3	27	41.5878	37	99	5.87359	77	171	1.29078	117	243	0.38991
-2	28	39.8239	38	100	5.62961	78	172	1.25423	118	244	0.37956
-1	30	37.1988	39	102	5.39689	79	174	1.2133	119	246	0.36954
0	32	35.2024	40	104	5.17519	80	176	1.17393	120	248	0.35982
1	34	33.3269	41	106	4.96392	81	178	1.13604	121	250	0.35042
2	36	31.5635	42	108	4.76253	82	180	1.09958	122	252	0.3413
3	37	29.9058	43	109	4.5705	83	181	1.06448	123	253	0.33246
4	39	28.3459	44	111	4.38736	84	183	1.03069	124	255	0.3239
5	41	26.8778	45	113	4.21263	85	185	0.99815	125	257	0.31559
6	43	25.4954	46	115	4.04589	86	187	0.96681	126	259	0.30754
7	45	24.1932	47	117	3.88673	87	189	0.93662	127	261	0.29974
8	46	22.5662	48	118	3.73476	88	190	0.90753	128	262	0.29216
9	48	21.8094	49	120	3.58962	89	192	0.8795	129	264	0.28482
10	50	20.7184	50	122	3.45097	90	194	0.85248	130	266	0.2777
11	52	19.6891	51	124	3.31847	91	196	0.82643	131	268	0.27078
12	54	18.7177	52	126	3.19183	92	198	0.80132	132	270	0.26408
13	55	17.8005	53	127	3.07075	93	199	0.77709	133	271	0.25757
14	57	16.9341	54	129	2.95896	94	201	0.75373	134	273	0.25125
15	59	16.1156	55	131	2.84421	95	203	0.73119	135	275	0.24512
16	61	15.3418	56	133	2.73823	96	205	0.70944	136	277	0.23916
17	63	14.6181	57	135	2.63682	97	207	0.68844	137	279	0.23338
18	64	13.918	58	136	2.53973	98	208	0.66818	138	280	0.22776
19	66	13.2631	59	138	2.44677	99	210	0.64862	139	282	0.22231

**ii) Temperature Sensor Resistance Value Table for TP(for some units) (°C --K)**

°C	°F	K Ohm	°C	°F	K Ohm	°C	°F	K Ohm	°C	°F	K Ohm
°C	°F	K Ohm	°C	°F	K Ohm	°C	°F	K Ohm	°C	°F	K Ohm
-20	-4	542.7	20	68	68.66	60	140	13.59	100	212	3.702
-19	-2	511.9	21	70	65.62	61	142	13.11	101	214	3.595
-18	0	483	22	72	62.73	62	144	12.65	102	216	3.492
-17	1	455.9	23	73	59.98	63	145	12.21	103	217	3.392
-16	3	430.5	24	75	57.37	64	147	11.79	104	219	3.296
-15	5	406.7	25	77	54.89	65	149	11.38	105	221	3.203
-14	7	384.3	26	79	52.53	66	151	10.99	106	223	3.113
-13	9	363.3	27	81	50.28	67	153	10.61	107	225	3.025
-12	10	343.6	28	82	48.14	68	154	10.25	108	226	2.941
-11	12	325.1	29	84	46.11	69	156	9.902	109	228	2.86
-10	14	307.7	30	86	44.17	70	158	9.569	110	230	2.781
-9	16	291.3	31	88	42.33	71	160	9.248	111	232	2.704
-8	18	275.9	32	90	40.57	72	162	8.94	112	234	2.63
-7	19	261.4	33	91	38.89	73	163	8.643	113	235	2.559
-6	21	247.8	34	93	37.3	74	165	8.358	114	237	2.489
-5	23	234.9	35	95	35.78	75	167	8.084	115	239	2.422
-4	25	222.8	36	97	34.32	76	169	7.82	116	241	2.357
-3	27	211.4	37	99	32.94	77	171	7.566	117	243	2.294
-2	28	200.7	38	100	31.62	78	172	7.321	118	244	2.233
-1	30	190.5	39	102	30.36	79	174	7.086	119	246	2.174
0	32	180.9	40	104	29.15	80	176	6.859	120	248	2.117
1	34	171.9	41	106	28	81	178	6.641	121	250	2.061
2	36	163.3	42	108	26.9	82	180	6.43	122	252	2.007
3	37	155.2	43	109	25.86	83	181	6.228	123	253	1.955
4	39	147.6	44	111	24.85	84	183	6.033	124	255	1.905
5	41	140.4	45	113	23.89	85	185	5.844	125	257	1.856
6	43	133.5	46	115	22.89	86	187	5.663	126	259	1.808
7	45	127.1	47	117	22.1	87	189	5.488	127	261	1.762
8	46	121	48	118	21.26	88	190	5.32	128	262	1.717
9	48	115.2	49	120	20.46	89	192	5.157	129	264	1.674
10	50	109.8	50	122	19.69	90	194	5	130	266	1.632
11	52	104.6	51	124	18.96	91	196	4.849			
12	54	99.69	52	126	18.26	92	198	4.703			
13	55	95.05	53	127	17.58	93	199	4.562			
14	57	90.66	54	129	16.94	94	201	4.426			
15	59	86.49	55	131	16.32	95	203	4.294			
16	61	82.54	56	133	15.73	96	205	4.167			
17	63	78.79	57	135	15.16	97	207	4.045			
18	64	75.24	58	136	14.62	98	208	3.927			
19	66	71.86	59	138	14.09	99	210	3.812			

### iii) Pressure On Service Port

#### Cooling chart(R32):

°F(°C)	ODU(DB)		0(-17)	5(-15)	15(-9.44)	45(7.22)	75(23.89)	85(29.44)	95(35)	105(40.56)	115(46.11)	120(48.89)
	IDU(DB/WB)											
BAR	70/59 (21.11/15)		6.5	6.6	7.4	8.2	8.4	8.0	8.3	8.8	10.3	10.8
	75/63 (23.89/17.22)		6.8	6.9	8.1	8.8	8.8	8.5	8.9	9.3	10.9	11.4
	80/67 (26.67/19.44)		7.2	7.3	8.7	9.7	9.5	9.1	9.3	9.8	11.4	12.1
	90/73 (32.22/22.78)		7.9	8.0	9.8	10.7	10.5	9.7	10.2	10.8	12.6	13.3
PSI	70/59 (21.11/15)		95	96	108	118	121	115	119	128	150	157
	75/63 (23.89/17.22)		99	101	117	128	126	122	129	135	158	165
	80/67 (26.67/19.44)		105	106	125	141	138	132	135	143	165	176
	90/73 (32.22/22.78)		114	115	142	155	152	141	148	157	184	193
MPa	70/59 (21.11/15)		0.65	0.66	0.74	0.82	0.84	0.80	0.83	0.88	1.03	1.08
	75/63 (23.89/17.22)		0.68	0.69	0.81	0.88	0.88	0.85	0.89	0.93	1.09	1.14
	80/67 (26.67/19.44)		0.72	0.73	0.87	0.97	0.95	0.91	0.93	0.98	1.14	1.21
	90/73 (32.22/22.78)		0.79	0.80	0.98	1.07	1.05	0.97	1.02	1.08	1.26	1.33

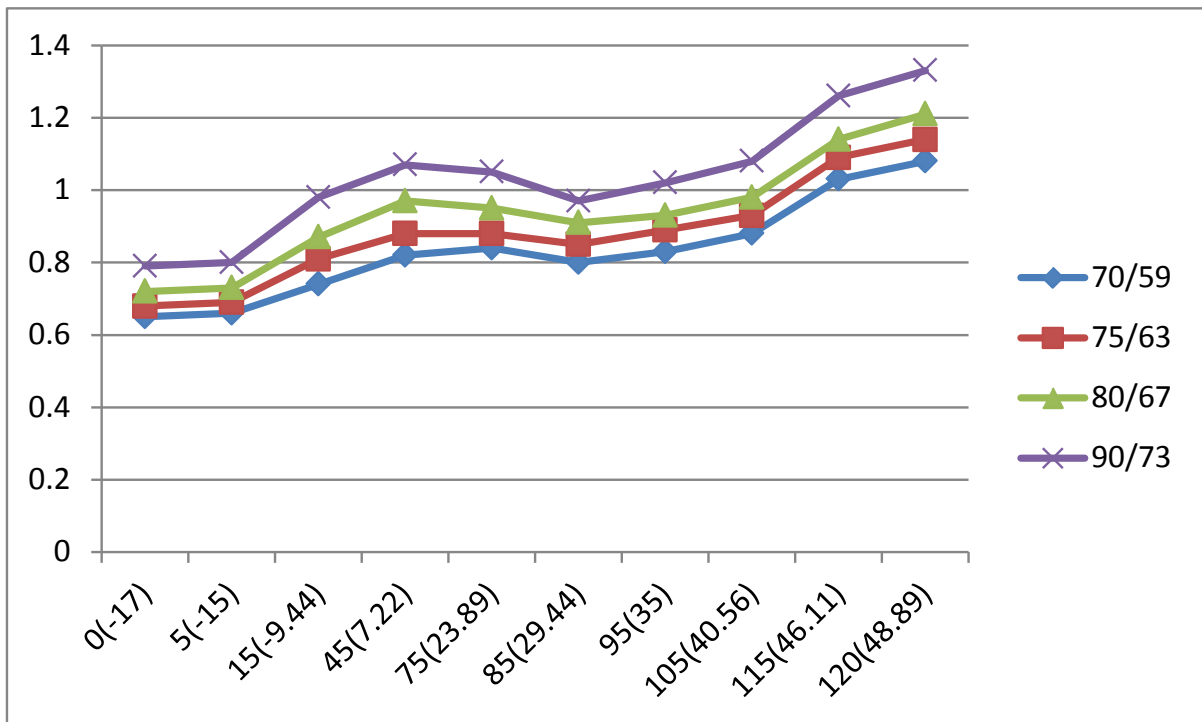



### Heating chart(R32):

°F(°C)	ODU(DB/WB)	57/53 (13.89/11.67)	47/43 (8.33/6.11)	37/33 (2.78/0.56)	27/23 (-2.78/-5)	17/13 (-8.33/- 10.56)	0/-2 (-17/-19)	-17/-18 (-27/-28)
	IDU(DB)							
BAR	55(12.78)	30.9	29.1	25.8	23.3	21.2	18.9	16.8
	65(18.33)	33.2	30.6	27.1	25.9	23.8	20.9	19.4
	75(23.89)	34.5	32.1	28.4	26.8	25.4	21.9	20.4
PSI	55(12.78)	448	421	374	337	308	273	244
	65(18.33)	480	444	394	375	346	303	282
	75(23.89)	499	466	411	389	369	318	296
MPa	55(12.78)	3.09	2.91	2.58	2.33	2.12	1.89	1.68
	65(18.33)	3.32	3.06	2.71	2.59	2.38	2.09	1.94
	75(23.89)	3.45	3.21	2.84	2.68	2.54	2.19	2.04

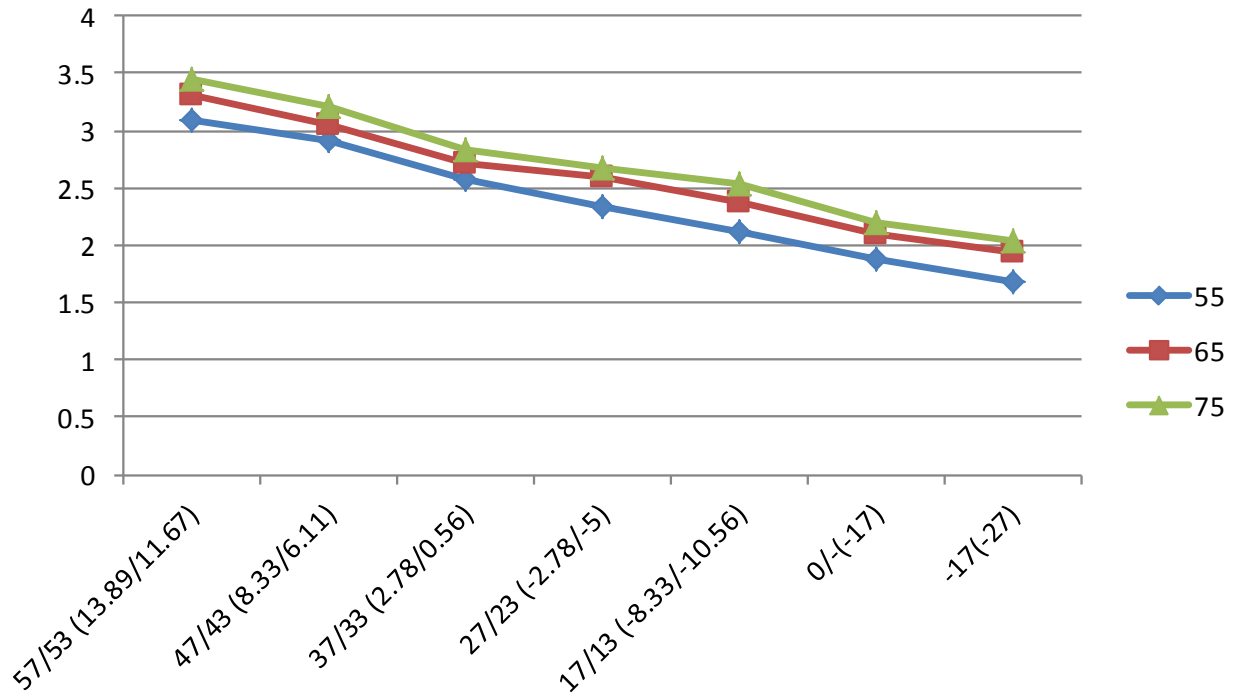

## System Pressure Table-R32

Pressure			Temperature		Pressure			Temperature	
Kpa	bar	PSI	°C	°F	Kpa	bar	PSI	°C	°F
100	1	14.5	-51.909	-61.436	1850	18.5	268.25	28.425	83.165
150	1.5	21.75	-43.635	-46.543	1900	19	275.5	29.447	85.005
200	2	29	-37.323	-35.181	1950	19.5	282.75	30.448	86.806
250	2.5	36.25	-32.15	-25.87	2000	20	290	31.431	88.576
300	3	43.5	-27.731	-17.916	2050	20.5	297.25	32.395	90.311
350	3.5	50.75	-23.85	-10.93	2100	21	304.5	33.341	92.014
400	4	58	-20.378	-4.680	2150	21.5	311.75	34.271	93.688
450	4.5	65.25	-17.225	0.995	2200	22	319	35.184	95.331
500	5	72.5	-14.331	6.204	2250	22.5	326.25	36.082	96.948
550	5.5	79.75	-11.65	11.03	2300	23	333.5	36.965	98.537
600	6	87	-9.150	15.529	2350	23.5	340.75	37.834	100.101
650	6.5	94.25	-6.805	19.752	2400	24	348	38.688	101.638
700	7	101.5	-4.593	23.734	2450	24.5	355.25	39.529	103.152
750	7.5	108.75	-2.498	27.505	2500	25	362.5	40.358	104.644
800	8	116	-0.506	31.089	2550	25.5	369.75	41.173	106.111
850	8.5	123.25	1.393	34.507	2600	26	377	41.977	107.559
900	9	130.5	3.209	37.777	2650	26.5	384.25	42.769	108.984
950	9.5	137.75	4.951	40.911	2700	27	391.5	43.55	110.39
1000	10	145	6.624	43.923	2750	27.5	398.75	44.32	111.776
1050	10.5	152.25	8.235	46.823	2800	28	406	45.079	113.142
1100	11	159.5	9.790	49.621	2850	28.5	413.25	45.828	114.490
1150	11.5	166.75	11.291	52.324	2900	29	420.5	46.567	115.821
1200	12	174	12.745	54.941	2950	29.5	427.75	47.296	117.133
1250	12.5	181.25	14.153	57.475	3000	30	435	48.015	118.427
1300	13	188.5	15.52	59.936	3050	30.5	442.25	48.726	119.707
1350	13.5	195.75	16.847	62.325	3100	31	449.5	49.428	120.970
1400	14	203	18.138	64.648	3150	31.5	456.75	50.121	122.218
1450	14.5	210.25	19.395	66.911	3200	32	464	50.806	123.451
1500	15	217.5	20.619	69.114	3250	32.5	471.25	51.482	124.668
1550	15.5	224.75	21.813	71.263	3300	33	478.5	52.15	125.87
1600	16	232	22.978	73.360	3350	33.5	485.75	52.811	127.060
1650	16.5	239.25	24.116	75.409	3400	34	493	53.464	128.235
1700	17	246.5	25.229	77.412	3450	34.5	500.25	54.11	129.398
1750	17.5	253.75	26.317	79.371	3500	35	507.5	54.748	130.546
1800	18	261	27.382	81.288					





# AIR CONDITIONING SYSTEMS

## FLOOR STANDING



V:1.0.062022

Manufacturer: **INVENTOR A.G. S.A.**

24th km National Road Athens - Lamia & 2 Thoukididou Str., Ag.Stefanos, 14565

Tel.: +30 211 300 3300, Fax: +30 211 300 3333 - [www.inventor.ac](http://www.inventor.ac)

